

MEGA WATER TANK-MX-2



GENUINE MEGA

SPECIALTY HAULAGE SOLUTIONS FOR CONSTRUCTION & MINING

➤ **MAINTENANCE MANUAL**



EQUIPMENT ➤ **PARTS** ➤ **SUPPORT** ➤



700 Osuna Rd. NE · Albuquerque, NM 87113

www.megacorpinc.com

TABLE OF CONTENTS

	Page
Section 1	Definitions and Abbreviations1-1
Section 2	Structure2-1
Section 3	Cab Control System3-1
Section 4A	Basic Hydraulics System (MAC/MAT, MTT/MWT).....4A-1
Section 4B	Basic Hydraulics System (MST/MSC)4B-1
Section 5	Water Pumps5-1
Section 6	Spray System6-1
Section 7	Water Cannon System.....7-1
Section 8	Fire Suppression System8-1
Section 9	Rear Brake System (MST/MSC)9-1
Section 10	Index10-1

MEGA WATER TANK-MX-2

17 OCT 2021

TABLE OF CONTENTS

SECTION 1

Definitions and Abbreviations

Contents

Manual Usage.....	1-1	MAC Overview (Typical)	1-6
Warning, Caution And Notes	1-1	MTT Overview (Typical).....	1-7
Use Of Shall, Will, Should And May	1-1	Rigid Hitch MST/MSC 8 Overview (Typical).....	1-8
Safety Messages	1-2	Drop Hitch MST/MSC 8 Overview (Typical).....	1-9
Abbreviations	1-5		

MANUAL USAGE

This technical manual only contains information required to safely install or service a MAC/MAT, MTT/MWT, or an MST/MSC. See the appropriate Maintenance and Operators Safety Manual for specific vehicle system information and maintenance procedures. If your system is not covered in this manual please contact MEGA Corp. Product Support Group at:

US toll free: 1-800-345-8889
 Direct: 1-505-345-2661

Or visit our website at www.megacorpinc.com for more detailed contact information.

The exact location of the hazards and descriptions of the hazards are reviewed in this section. All personnel working on or operating the Mega water truck must become familiarized with all the safety messages.

⚠ WARNING

Due to the nature of these processes, ensure that all safety information, warnings and instructions are read and understood before any operation or any maintenance procedures are performed. Some procedures take place with heavy components and at moderate heights, ensure proper safety procedures are maintained when performing these actions. Failure to use and maintain proper safety equipment and procedures will cause injury, death or damage to equipment.

NOTE

Only portions of scheduled maintenance inspections, special inspections and recommended support parts mat apply to CAT WDS water tanks. Use the -4 installation and appendix drawings to determine applicability.

WARNING, CAUTION AND NOTES

The following definitions are found throughout the manual and apply as follows:

⚠ WARNING

Operating procedures and techniques, which could result in personal injury and/or loss of life if not carefully followed.

CAUTION

Operating procedures and techniques, which could result in damage to equipment if not carefully followed.

NOTE

Operating procedures and techniques that are considered essential to emphasize.

USE OF SHALL, WILL, SHOULD AND MAY

Shall and **Will** – Used when application of a procedure is mandatory.

Should – Used when application of a procedure is recommended.

May - Used to indicate an acceptable or suggested means of accomplishment.

SECTION 1

Definitions and Abbreviations

SAFETY MESSAGES

There are several specific safety messages on this machine. The exact location of the hazards and description of the hazards are reviewed in this section. All personnel working on or operating the machine must become familiarized with all the safety messages.

Make sure that all of the safety messages are legible. Clean or replace the safety messages in you cannot read the words. Replace the illustrations if the illustrations are not legible. When you clean the safety messages, use a cloth, water, and soap. Do not use solvent, gasoline, or other harsh chemicals to clean the safety messages. Solvents, gasoline, or harsh chemicals could loosen the adhesive that secures the safety messages. Loose adhesive will allow the safety messages to detach.

Replace any safety message that is damaged or missing. If a safety message is attached to a part that is replaced, install a new safety message on the replacement part.

Toxic Gas Hazard (1)

This safety label is located on the side of the tank and at all water fill entrances.

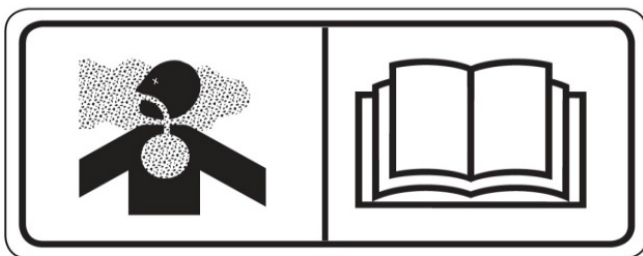

⚠ WARNING

Cutting or welding operation on the inside of the tank can cause the accumulation of toxic gases. Read and understand instructions and warnings in the Maintenance Manual. Failure to provide proper ventilation or breathing apparatus while conducting these operations may result in serious injury or death.

Do Not Operate (2)

This safety label is located on the outside of the front and rear control boxes (if equipped).

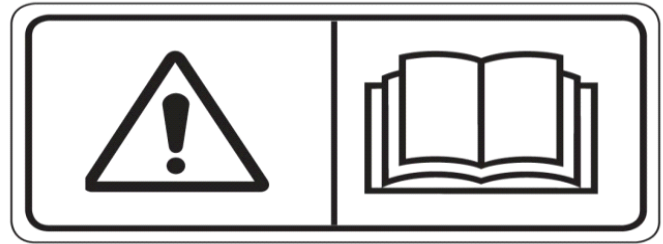

⚠ WARNING

Do not open this control box unless you read and understand the instructions and warnings in the Operator and Maintenance Manual. Failure to follow instructions or heed the warnings could result in serious injury or death.

Backing Run Over Hazard (3)

This safety label is located on the rear of the tank and inside the cab.

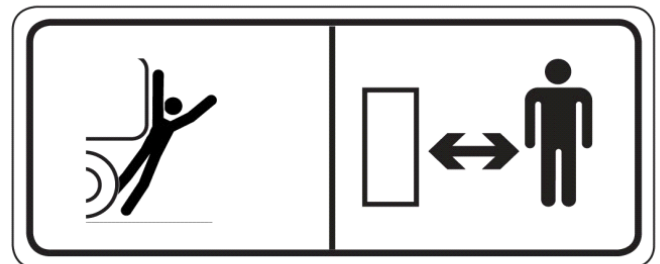

⚠ WARNING

The vehicle is equipped with a back-up alarm. Alarm must sound when operating this vehicle in reverse. Failure to maintain a clear view in the direction of travel could result in serious injury or death.

SECTION 1

Definitions and Abbreviations

Freezing (4)

This safety label is located on the side of the tank, at the sump drain, and on the pump.

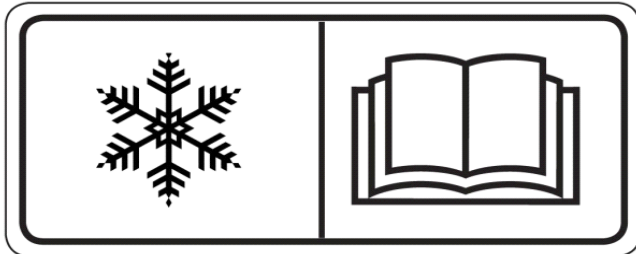

⚠ WARNING

Drain tank, fill pipe and valve in freezing weather. Refer to the Operator and Maintenance Manual for the procedure to follow.

Non-Potable (5)

This safety label is located on the side of the tank and sump drain.

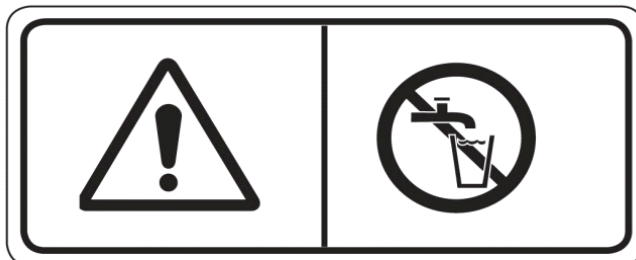

⚠ WARNING

Water held within tank is not potable. Do not use tank for transport of water intended for human or animal consumption or serious injury or death may result.

Do Not Hoist While in Motion (6)

This safety label is located inside the cab.



⚠ WARNING

Do not engage hoist cylinders while vehicle is in motion. Before engaging hoist, STOP the vehicle. Do not engage hoisting cylinders unless you read and understand the instructions and warnings in the Operator or Maintenance Manual. Failure to follow instructions or heed the warnings will result in injury or death.

Fall Hazard (7)

This safety label is located at the top of the front and rear of the tank.

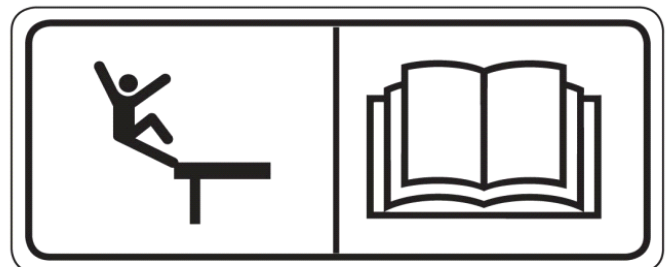

⚠ WARNING

Do not walk on the top of tank without fall arrest PPE. Serious injury or death could occur from a fall.

SECTION 1

Definitions and Abbreviations

Rotating Shaft (8)

This safety label is located on the pump.

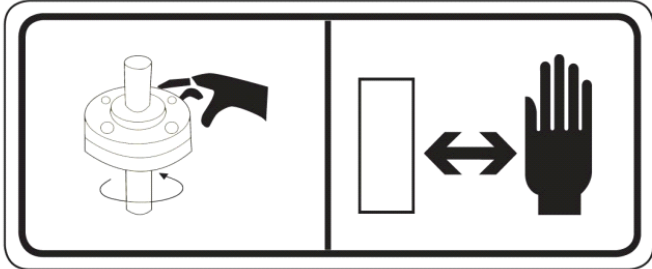

⚠ WARNING

Do not place your hand or tools within pump bell while pump is rotating and/or pressure held within the motor supply hose. Refer to the Operator and Maintenance Manual for the procedures to operate and maintain the pump. Failure to follow proper procedures could result in serious injury.

High Pressure Water Cannon (10)

This safety label is located on top of the cab control box.

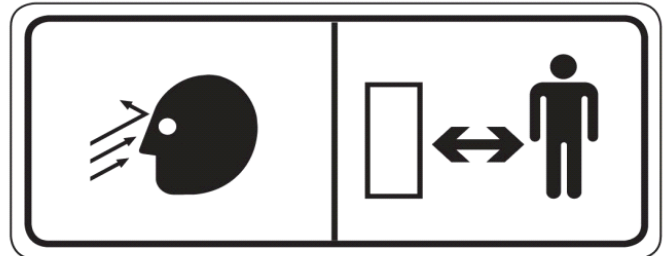

⚠ WARNING

Do not operate the water cannon until all personnel are a safe distance away from the vehicle.

High Pressure Spray Heads (9)

This safety label is located on the spray bar.

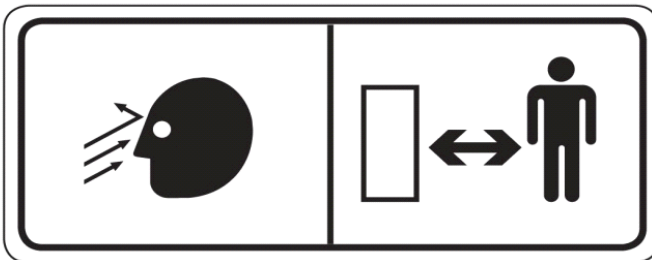

⚠ WARNING

Do not operate spray heads until all personnel are a safe distance away from the vehicle.

High Pressure Motor (11)

This safety label is located on the hydraulic motor.

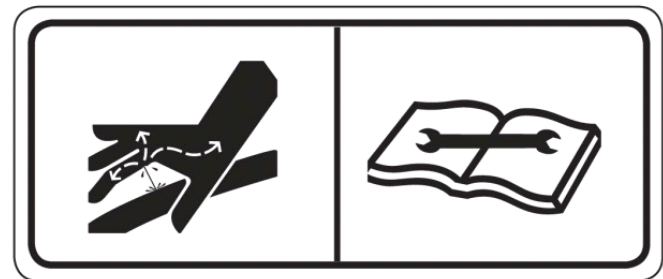

⚠ WARNING

Hydraulic motor and supply lines contain oil under high pressure. Improper removal and repair procedures could cause severe injury. To remove or repair, instructions in the Maintenance Manual must be followed.

SECTION 1

Definitions and Abbreviations

Confined Space (12)

This safety label is located near the water tank access and fill ports.

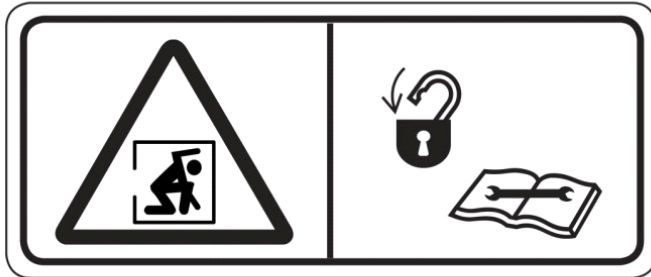

⚠ WARNING

Do not enter confined spaces without following established site specific procedures. Failure to follow proper safety procedures will result in serious injury or death.

ABBREVIATIONS

BFV	Butterfly Valve
cc	Cubic Centimeters
CCW	Counter Clockwise
CW	Clockwise
fl. oz.	Fluid Ounce
FT	Feet
Ft-lbs	Foot-pounds (unit of torque)
FPM	Feet Per Minute
GPM	Gallons Per Minute
IN/SQ FT	Inches per Square Feet
KM-H	Kilometers Per Hour
Kg	kilograms
Kpa	Kilopascals
l	liters
lpm	Liters per minute
LT	Left as viewed from the operator's position facing forward
m	meters
mm	millimeters
MPH	Miles Per Hour
MAC	Mega Articulated Truck Conversion
MAT	Mega Supplied Articulated Truck and Tank
MSC	Mega Scraper Conversion
MST	Mega Supplied Scraper Tractor and Tank

ABBREVIATIONS (CONT'D)

Nm	Newton meters (unit of torque)
psi	pounds per square inch
RPM	Revolutions Per Minute
RT	Right as viewed from the operator's position facing forward
SQ FT	Square Feet
VDC	Volts, Direct Current

SYMBOLOLOGY

Symbol	Name	Symbol	Name	Symbol	Name
	POWER		WATER LEVEL		DRAIN
	PUMP		DUMP BAR		RT VSS
	INTMNT /AUTO2		AUTO		LT REAR
	LIGHTS		AUX 1		LT CTR
	F1		AUX 2		RT CTR
	F2		HOSE		RT REAR
	PAUSE		LT VSS		

SECTION 1

Definitions and Abbreviations

MAC OVERVIEW (TYPICAL)

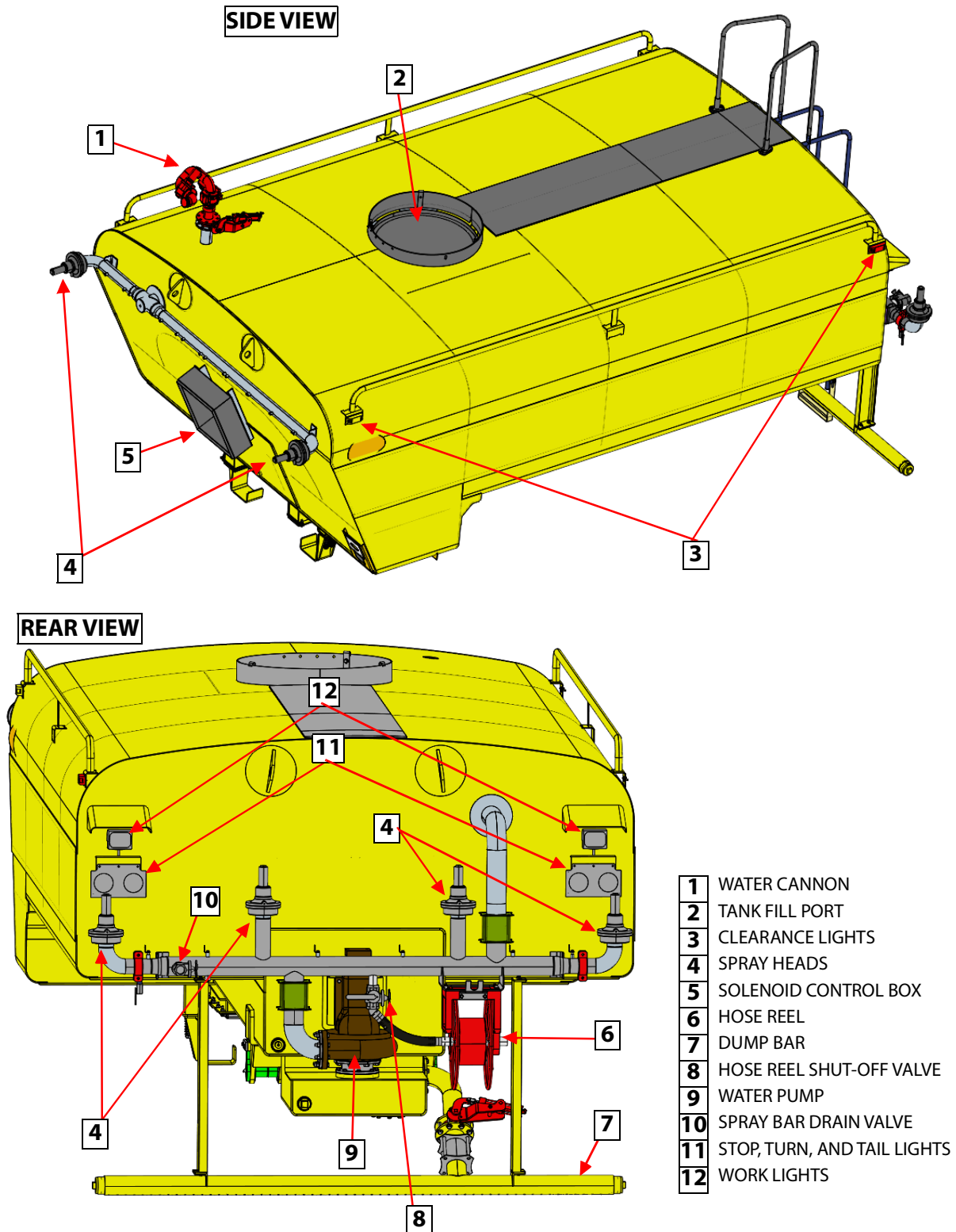

SECTION 1 Definitions and Abbreviations

MTT OVERVIEW (TYPICAL)

SIDE VIEW

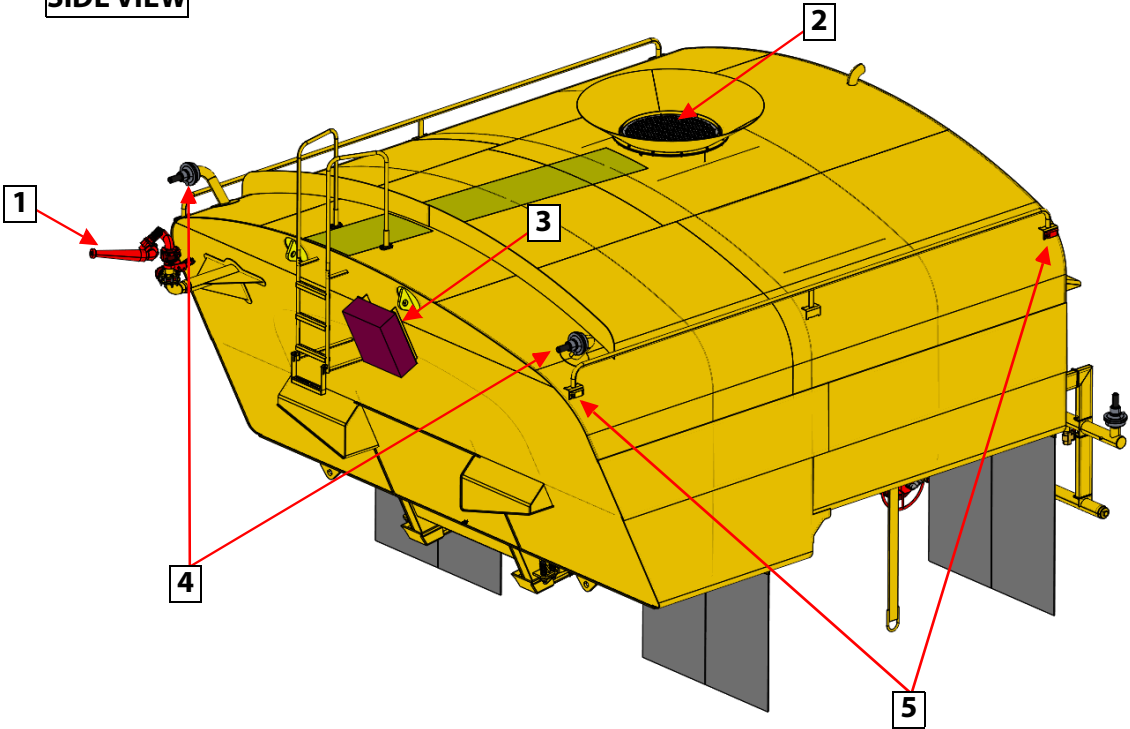

REAR VIEW

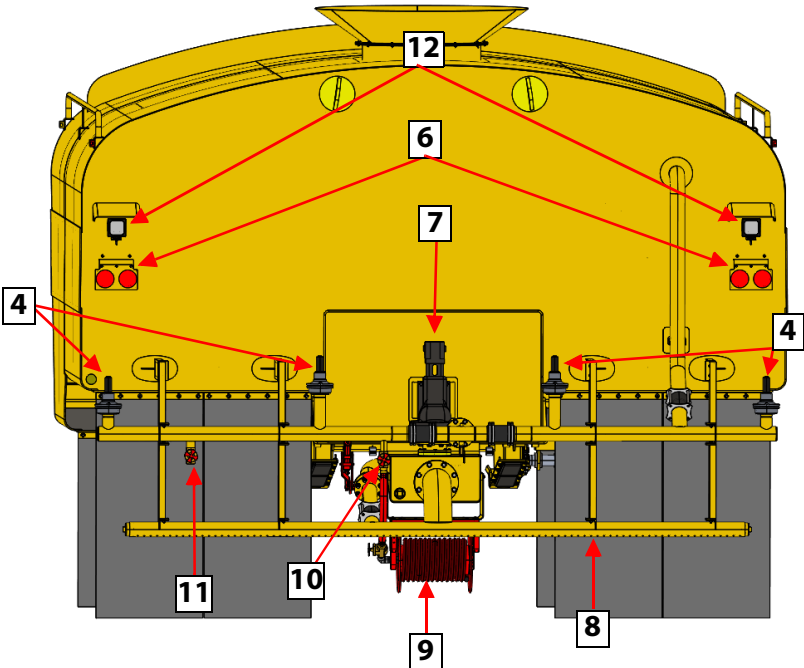

- 1 WATER CANNON
- 2 TANK FILL PORT
- 3 SOLENOID CONTROL BOX
- 4 SPRAY HEADS
- 5 CLEARANCE LIGHTS
- 6 STOP, TURN, AND TAIL LIGHTS
- 7 WATER PUMP
- 8 DUMP BAR
- 9 HOSE REEL
- 10 HOSE REEL SHUT-OFF VALVE
- 11 SPRAY BAR DRAIN
- 12 WORK LIGHTS

SECTION 1

Definitions and Abbreviations

RIGID HITCH MST/MSC 8 OVERVIEW (TYPICAL)

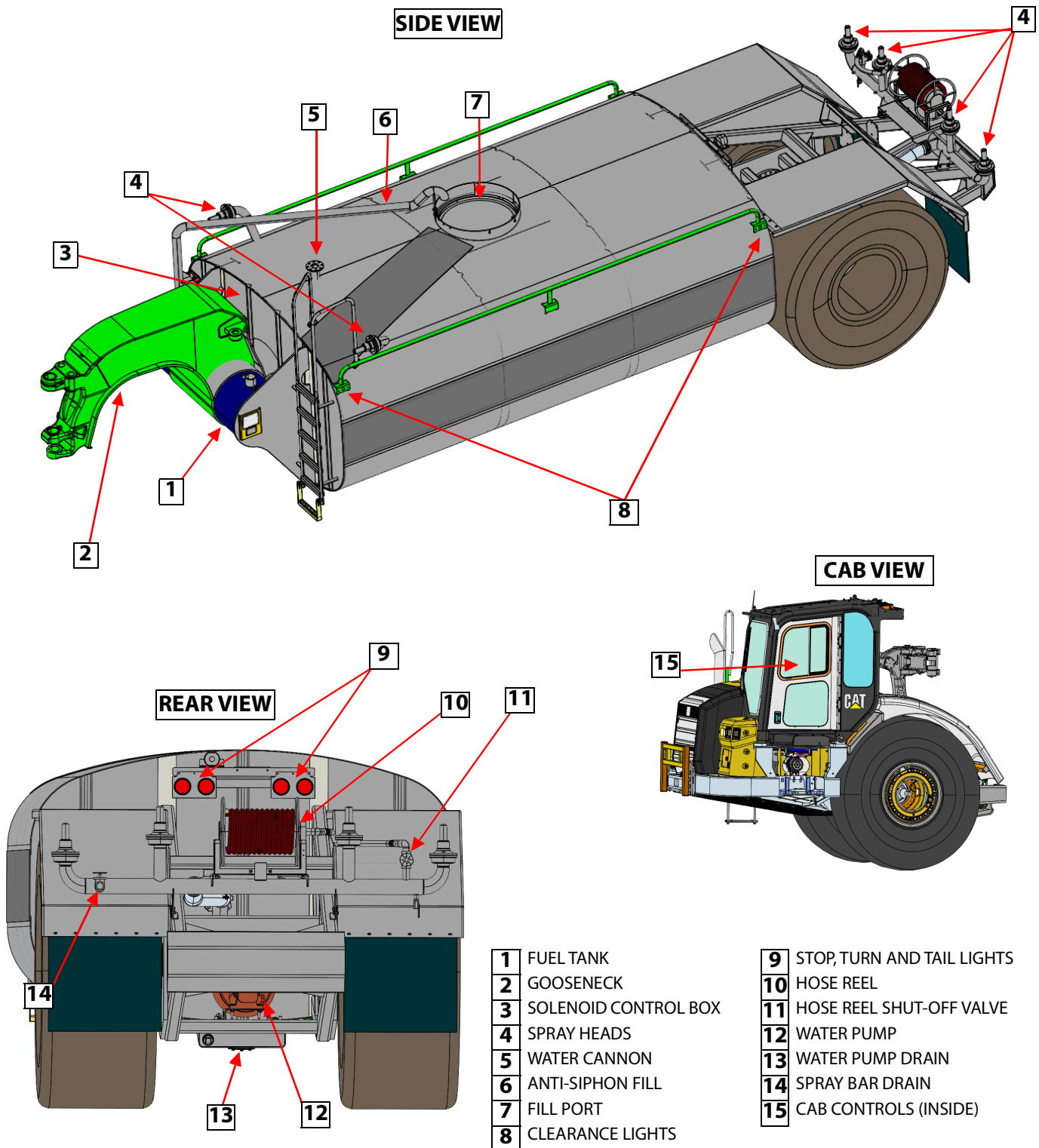

SECTION 1 Definitions and Abbreviations

DROP HITCH MST/MSC 8 OVERVIEW (TYPICAL)

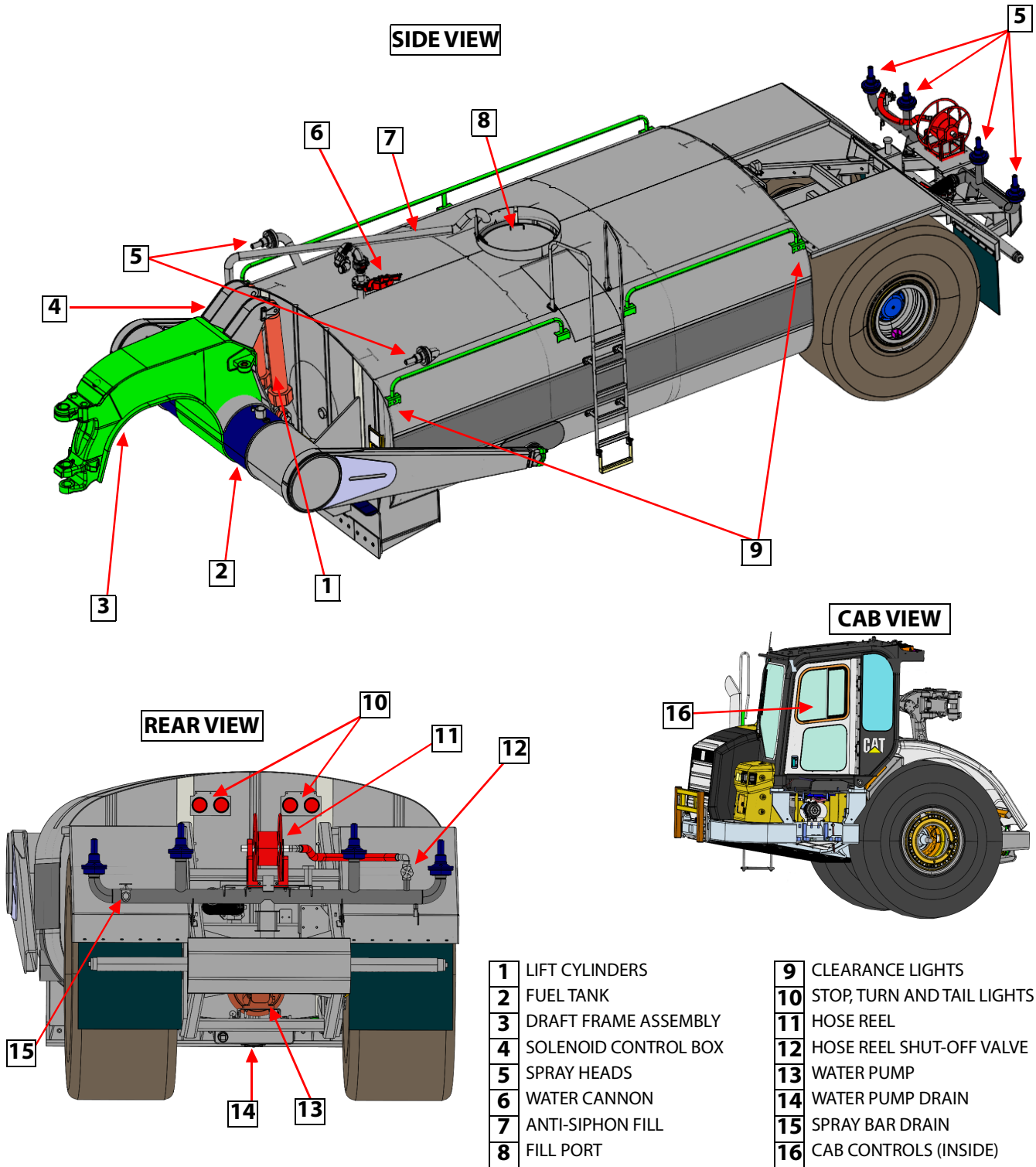

- 1** LIFT CYLINDERS
- 2** FUEL TANK
- 3** DRAFT FRAME ASSEMBLY
- 4** SOLENOID CONTROL BOX
- 5** SPRAY HEADS
- 6** WATER CANNON
- 7** ANTI-SIPHON FILL
- 8** FILL PORT

- 9** CLEARANCE LIGHTS
- 10** STOP, TURN AND TAIL LIGHTS
- 11** HOSE REEL
- 12** HOSE REEL SHUT-OFF VALVE
- 13** WATER PUMP
- 14** WATER PUMP DRAIN
- 15** SPRAY BAR DRAIN
- 16** CAB CONTROLS (INSIDE)

SECTION 1
Definitions and Abbreviations

SECTION 2 Structure

Contents

Water Tank (MAC/MAT, MTT/MWT)	2-1	Inspection.....	2-5
Water Tank (MST/MSC)	2-1	Repair	2-5

WATER TANK (MAC/MAT, MTT/MWT)

The MEGA MAC/MAT and MTT/MWT steel water tanks consist of a water tub, primary floor, vertical baffles, bulkheads, outer skins, and external piping. The tank design known as the Mega Anti-Surge Stabilization System (MASS).

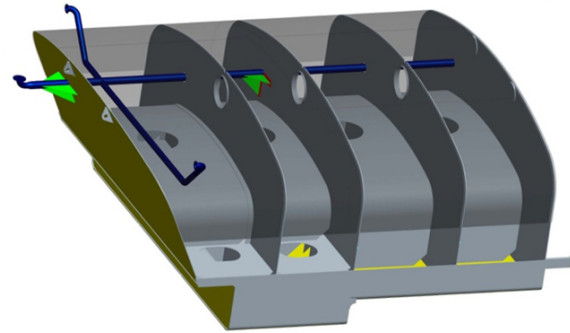
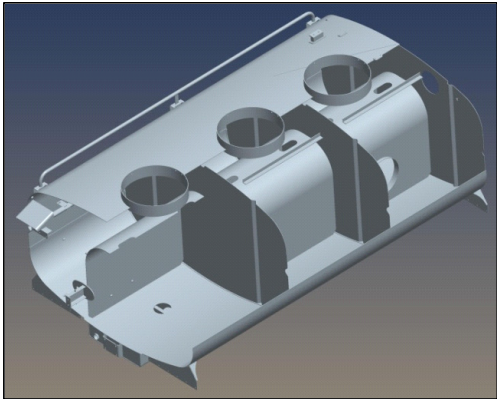

The tank structure is built around and on top of the tub super structure. The tub provides support to the floor plate, pivot structure, baffles, and mounting for the water pump. The floor plate carries loads while the baffles and bulkheads add to tank strength and dampen water surges. External piping is also used to carry water from the water pump to spray heads, water cannon, spray bar, hose reel, dump bar, and tank drain.

The tanks' interiors may be coated with an epoxy or an Aluminum Polyurethane finish to reduce the effects of corrosive environments and extremely harsh water conditions.

WATER TANK (MST/MSC)

The MEGA MST/MSC steel water tank consists of upper and lower dual radius skins enclosing the MEGA Anti-Surge Tube (MAST) and transverse reinforced baffles.

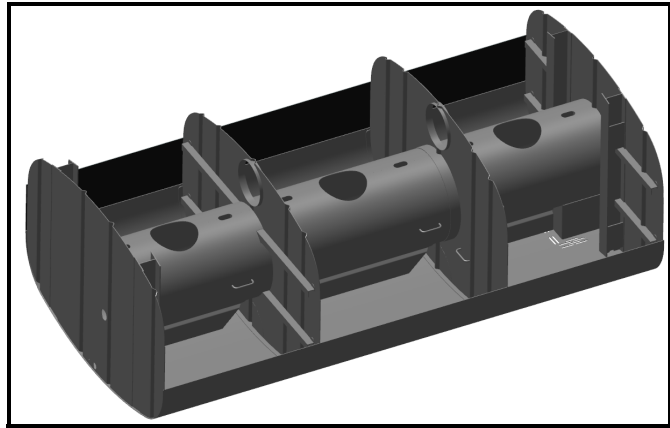

The MAST is the backbone of the structure and provides mounting for transverse baffles. The baffles add to tank strength and dampen water surges. The forward baffles are reinforced with vertical beams to provide mounting for the goose neck or rigid hitch. The rear baffles, also reinforced with vertical beams, provide mounting for the rear trailing axle. External and internal piping is used to carry water from the water pump to spray heads, water cannon, spray bar, hose reel, dump bar, and tank drain.

The tanks' interiors may be coated with an epoxy finish to reduce the effects of corrosive environments and extremely harsh water conditions.

ANODES

There will be anodes located either on the interior or exterior of the tank. These anodes are to help prevent corrosion from forming on the interior of the tank.

SECTION 2

Structure

HOISTING PROCEDURES (IF APPLICABLE)

(Hoist-Compatible Units Only)

Configurations may differ between tank serial numbers, depending upon customer requirements and modifications. Hoisting and reconfiguration procedures may vary based on these modifications.

Preparing And Hoisting Tank

1. Ensure unit contains no water. Remove sump access cover to ensure tank is free from water.
2. Place unit on solid, level work area with proper clearance to accommodate the hoisted tank.

⚠ WARNING

Follow appropriate lock-out-tag-out procedures.

3. Remove electrical and hydraulic power from unit.
4. Remove components (e.g. drain bar, hose reel...) bolted to the bottom of the water pump sump that may be damaged when tank is hoisted.

CAUTION

Ensure all components that may cause interference with chassis to tank when tank is hoisted are disconnected and/or removed from tank or chassis. Failure to remove components will cause damage to the tank and/or chassis.

5. Disconnect and plug pilot oil supply hose.
6. Disconnect ALL control wiring that may be damaged when tank is hoisted.
7. Locate and secure tank lock back pins or restraining device.
8. Remove body retaining bolts.
9. Ensure the 40 pin electrical cable connector (truck to forward solenoid box) is disconnected and removed from the forward solenoid box and tank.

10. Ensure the 2 conductor hoist valve control cable (forward junction box to hoist valve) is disconnected and removed from the hoist valve and tank.
11. Ensure the OEM hoist control wiring is connected to hoist valve.
12. Ensure the water pump **pressure** hydraulic hose is connected to the **blank** port of the dual flange blanking plate as shown below.

⚠ WARNING

Ensure all hydraulic pressure has been removed from hydraulic circuit prior to removing hoses. Removing pressurized hoses may result in personnel injury or death.

CAUTION

Use care when removing and installing hoses. Unclean handling will induce dirt and debris, which may result in damage to hydraulic components.

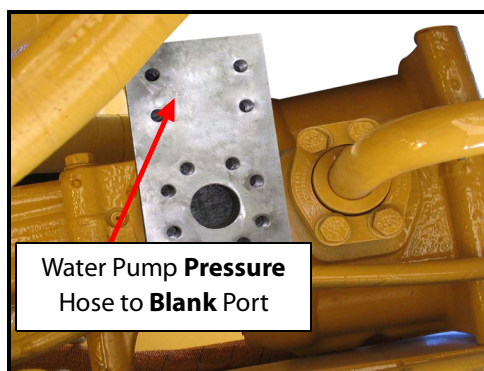

SECTION 2

Structure

13. Ensure the hoist cylinder **raise** supply hose is connected to the **open** port of the dual flange blanking plate on the hoist valve.

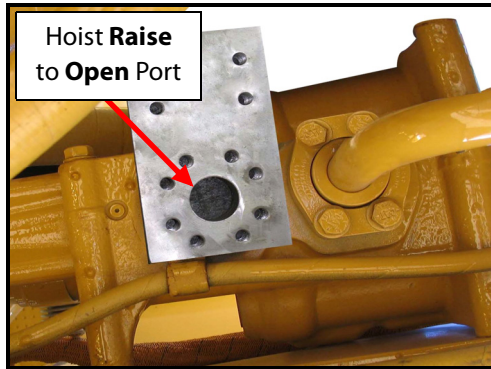

14. **(Komatsu ONLY)** Reconfigure EPC valve to enable Hoist EPC controls. Refer to the MEGA field installation manual or Komatsu Maintenance manual specific to your tank for details.
15. Restore electrical power to chassis.
16. **(CAT ONLY)** Gain access to ECM and reconfigure hoist control to **"ENABLE."** Refer to Section 8 of the appropriate MEGA Field Installation Manual for your unit.
17. **(CAT, DiSCS®, AND NON-PEDESTAL MOUNT ONLY)** Remove the cab control switch box from the switch box mounting plate and insert the hoist shaft and handle into the hoist lever mechanism.

18. **(CAT ONLY)** Start engine and perform operational check of the gear shift lever and hoist lever as per CAT SIS. Ensure that the gear shift lever parking brake, transmission hold, and reverse disable function properly. Also ensure that the hoist lever raise, hold, float, and lower functions operate properly.

⚠ WARNING

Gear shift lever & hoist lever controls must be checked to ensure proper functionality. **Incorrect functionality may cause serious injury or death.**

CAUTION

Ensure all proper hoisting procedures are followed. Failure to use a spotter to observe and correct any clearance issues may result in damage to the tank or truck while hoisting.

19. Raise tank slowly until tank lock back holes align.
20. Insert and secure lock back pins or restraining devices in the provided holes or fixtures.
21. Remove electrical and hydraulic power from unit.

Lowering

22. Restore electrical and hydraulic power to unit.
23. Raise tank to remove lock back pins or restraining devices.
24. Lower tank to chassis.

CAUTION

Ensure all proper hoisting procedures are followed. Failure to use a spotter to observe and correct any clearance issues may result in damage to the truck or truck while hoisting.

25. When tank is lowered and resting on chassis frame rails, remove electrical and hydraulic power from unit.

SECTION 2

Structure

26. Place lock back pins or restraining devices in proper holding fixtures.

Hoist Valve Reconfiguration For Water Tank Application

1. Reposition and secure the hoist cylinder **raise** hose to the **blank** port of the dual flange blanking plate as shown below and in Section 10.

⚠ WARNING

Ensure all hydraulic pressure has been removed from hydraulic circuit prior to removing hoses. Removing pressurized hoses may result in personnel injury or death.

CAUTION

Use care when removing and installing hoses. Unclean handling will induce dirt and debris resulting in possible damage to hydraulic components.

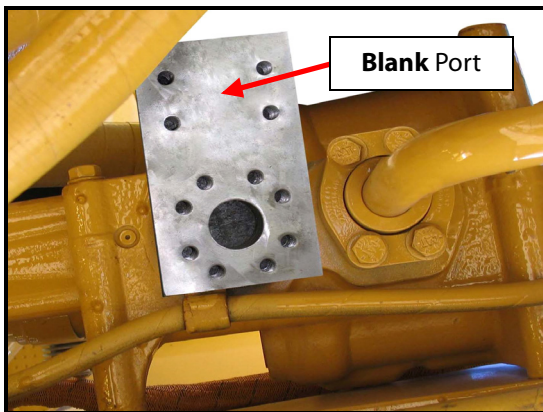

2. Reposition and secure the water pump **pressure** hose to the **raise** port of the dual flange blanking plate as shown below and in Section 10.

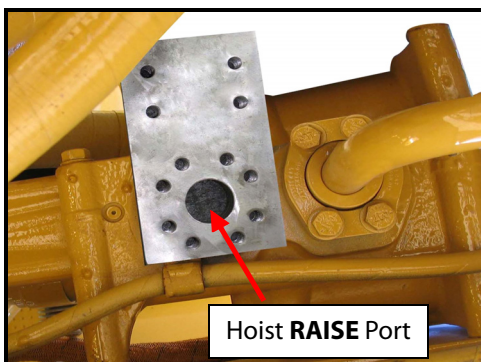

3. Reinstall all accessories that were removed prior to hoisting of the tank due to interference.

4. Replace sump access cover.

5. Reinstall body retaining bolts.

CAUTION

When tightening body retaining bolts, ensure that the springs are compressed only 1/2". Over-tightening will cause damage to the tank or front mounting.

6. Reinstall and secure the 40 pin control cable to forward junction box and tank.

7. Disconnect and cap OEM hoist valve control wiring from hoist valve.

8. Reinstall pilot oil supply hose to solenoid control box oil filter.

9. Reconnect any control cabling that was disconnected prior to hoisting.

10. Reconnect the 2-conductor hoist valve control cable to hoist raise solenoid of hoist valve and secure to tank and chassis.

11. **(Komatsu ONLY)** Reconfigure EPC valve to disable Hoist EPC controls as detailed in the Mega field installation manual specific to your tank.

12. Restore electrical power to unit.

13. **(CAT ONLY)** Gain access to ECM and change hoist control to **"NOT INSTALLED"**.

SECTION 2

Structure

Mandatory Water Pump Operational Check After Reconfiguration

14. Startup vehicle and turn on the control system.
15. Turn the Cab Control PUMP Switch ON.

CAUTION

Only operate the water pump low idle for no longer than 2.5 minutes without water in tank. Running the water pump longer than 2.5 minutes without water in the tank will result in water pump shaft/seal damage or complete failure.

16. Check to ensure water pump is spinning CW and all hydraulic components are free of oil leaks.
17. Refer to the appropriate Service and Maintenance Manual for proper fluid levels and types. Ensure hydraulic fluid levels are correct.
18. Perform a full operational check as outlined in your Field Installation Manual: Section 9 "Functional Check Procedures" before releasing and returning the unit to service.

INSPECTION

1. Inspect tank exterior paint for wear and corrosion.
2. Inspect tank outer skins for damage or leaks.
3. Inspect tank outer structure for damage.
4. **(Interior coating equipped only)** Inspect tank interior coating for wear, condition, and deterioration. Repair as required.
5. Inspect all water ways, pipes, and couplings for security, wear, and leaks.
6. Inspect all tank mounted wiring, and hydraulic hoses for wear, security, and leaks.

REPAIR

Paint

Remove corrosion. Prime and paint.

Interior Coating (Epoxy or Urethane)

1. Brief and follow all local confined space entry requirements and procedures.

WARNING

Do not enter confined spaces without following established site specific procedures. Failure to follow proper safety procedures will result in serious injury or death.

2. Use all required safety equipment and procedures to perform grinding and painting of interior coatings. Refer to coating manufacturer's MSDS information.
3. Inspect coating for flaking, bubbling or cracking.
4. Remove damaged coating via wire brush wheel or grinder. Ensure coating is removed about 1-2" beyond the visible crack.
5. Wipe area clean and inspect exposed edges of the coating. Ensure exposed edges of the coating still adhere to the metal surface.
6. Wipe clean with Prep Sol or equivalent preparation solution to remove debris and/or oil.
7. Mix Epoxy or Urethane coating according the manufacturer's instructions.
8. Apply coating with roller or natural haired brush. Ensure coating is applied at the manufacturer's recommended thickness. See MSDS sheet for details.
9. Allow sufficient time for the coating to cure before filling tank with water.

SECTION 2

Structure

Leaks

1. Remove paint and corrosion from suspected area.
2. Weld over leak.
3. Prime and paint over weld.

Structure

Contact MEGA Product Support for assistance on major structural repair:

US toll free: 1-800-345-8889

Direct: 1-505-345-2661

Or visit our website at www.megacorpinc.com for more detailed contact information.

SECTION 3 Cab Control System

Contents

Description	3-1	Inspection (Digital)	3-26
Inspection (Analog)	3-2	Repair (Digital)	3-26
Repair (Analog)	3-2	Configuration & Programming, DiSCS® 2.0	3-34
Cab Control System (DiSCS® 2.0)	3-16	Configuration & Programming, DiSCS® 1.5	3-53
Cab Control system (DiSCS® 1.5)	3-16	Troubleshooting (DiSCS® 1.5 ONLY)	3-69

DESCRIPTION

Multi-function control box that is mounted in the vehicle cab to control all water tank functions. There are two types: analog and digital. Controls are available for the water cannon, intermittent spray, water pump, work lights, foam suppression, adjustable nozzle, system, spray heads, spray bar, gravity dump bar and tank drain valve. Some systems are equipped with a low water shut-off system that turns off the water pump during low water levels. The box also provides indications of tanker water level and a system fuse holder. The cab controls requires 24 VDC vehicle power to operate.

CAB CONTROL SYSTEM (ANALOG)



The control box and joystick have a modular design, which allows the joystick to be detached from its holding bracket and operated separately as needed. Older hydraulic control boxes do not have this functionality, but they can be upgraded to the latest design by MEGA.

The analog cab control functions operate as follows:

Control	Function
Joystick	Sends command signals to the logic box (electric water cannon) or hydraulic control valve assembly (hydraulic water cannon) to move the water cannon left, right, up and down.
FOAM	Open or closes the foam concentrate tank in-line control valve.
FOG	On adjustable nozzle water cannons, adjusts cannon for less concentrated flow (HOLD for adjustment)
STREAM	On adjustable nozzle water cannons, adjusts cannon for more concentrated flow (HOLD for adjustment)
TIMER OFF	Sets OFF time (variable adjustment 5-100 sec) between timer cycles of selected spray heads and dump bar when the timer switch is in the intermittent position.
TIMER ON	Sets ON time (variable adjustment 5-100 sec) of selected spray heads and dump bar when the timer switch is in the intermittent position
PUMP	Routes vehicle hydraulic system pressure and flow to the water pump hydraulic drive motor.
MONITOR	Opens the water cannon BFV.
LIGHTS	Provides power to work lights.
TIMER	Activates or deactivates system timer function.

SECTION 3

Cab Control System

Control	Function
DRAIN	Opens or closes tank drain BFV.
DUMP BAR	Opens or closes dump bar BFV.
WATER LEVEL	Indicates tank water level.
SYSTEM	Provides power for all cab control functions.
LT BUMPER	Opens or closes left front bumper spray head.
LT VSS	Opens or closes left vertical side spray head.
LT REAR	Opens or closes left rear spray head.
LT CENTER	Opens or closes left center rear spray head.
RT CENTER	Opens or closes right center rear spray head.
RT REAR	Opens or closes right center rear spray head.
RT VSS	Opens or closes right vertical side spray head.
RT BUMPER	Opens or closes right front bumper spray head.
AUX 1	Reserved for specialized functions.
AUX 2	Reserved for specialized functions.

INSPECTION (ANALOG)

1. Inspect cab control box and cabling for security, condition and mounting.
2. Inspect switches and joystick for security, condition and operation.

REPAIR (ANALOG)

Switch Replacement

1. Remove power to the cab control.
2. Remove cab control face plate to gain access to the switch.
3. Mark wiring on old switch before removal to ensure correct wiring configuration is maintained.
4. Remove old switch and replace with the same type of switch.
5. Install wiring on new switch as previously marked.

Joystick Replacement

1. Remove power to the cab control.
2. Remove cab control face plate to gain access to joystick switch deck.
3. Rotate switch deck C.C.W. 90 degrees to remove switch deck from joystick assembly.
4. Disconnect wiring harness from old joystick without removing wire ties.
5. Installed wire harness on new joystick switch deck.
6. Locate new switch deck on joystick assembly and rotate switch deck C.W. to engage and secure switch deck.
7. Apply power to the cab control and perform functional check of the newly installed switch deck.

SECTION 3

Cab Control System

DRIVER CARD COMPONENT IDENTIFICATION

DESCRIPTION

(AUGUST 2017 TO PRESENT PRODUCTION MODELS)The MEGA control system uses a digital driver card to send electronic signals to the hoist or implement valve actuator coil on certain prime movers. This electronic signal matches the OEM signal sent by the chassis ECM. This signal is set to limit current sent to the actuator coil to prevent damage to the coil and provide a soft start/stop by ramping the current up/down slowly to the actuator coil to reduce hydraulic and water hammer or shock to the systems that may cause component failure. The original driver card has been discontinued from the manufacture and an update to the current production design will be required if replacing a failed driver card. This document is intended to assist with the removal and installation of the new driver card and additional wiring required.

CAUTION

Chassis model is required to provide the correct driver card output configuration. Failure to provide correct chassis information, installation into a different or incorrect application will result in poor performance and/or component damage.

REPLACEMENT PROCEDURE

REQUIRED TOOLS

- Allen Wrench Set
- Assorted small wrenches
- Phillips Screw Driver
- Thin blade, small flat tip screw driver
- Quality wire strippers
- Quality wire connector crimpers
- Heat Gun (for heat shrink connectors)
- Pin Extractor (to remove connectors from 40-pin connector)

INSTRUCTIONS

1. Isolate tractor electrical power source.
2. Disconnect cab control 40 pin connector.
3. Remove cab control box from mount.
4. Place on clean work bench or table.
5. Remove six (6) screws used to secure cab control face plate to box.
6. Identify driver card, wiring and power sources using drawing 051726 and 051903 for reference, **typically found in the appendix**.
7. Remove old driver card by removing four (4) nuts used to secure it to the box.
8. Note all wiring colors and locations.
9. With thin blade flat tip screwdriver loosen terminal strip screws for wires.
10. Remove wiring from old driver card.
11. Insert new wiring in new driver card terminal strip as per reference 051726 and 051903 drawings.
 - a. Use small blade flat tip screw driver and depress terminal release, push wire into terminal until stripped wire is fully inserted into terminal.
 - b. Release pressure from screw driver and inspect wire, observe that no bare wire is exposed and wire is fully seated.
 - c. Ensure wire is completely inserted and secure in terminal strip by pulling wire.
 - If wire comes out of terminal, clean up stripped end and re-insert wire by depressing the terminal release. Re-inspect wire for seating and security.

NOTE

This section describes the replacement procedure for the previous version (pre-August 2017) driver card in the control system that uses the 40 pin connections.

SECTION 3 Cab Control System

CAUTION

Use caution when depressing terminal strip release. Applying too much pressure to terminal release will result in plastic terminal release to break off and fail. Ensure the correct 18 gauge wire is used in the new drive card. Failure to use correct wire size will damage the driver card terminal strip.

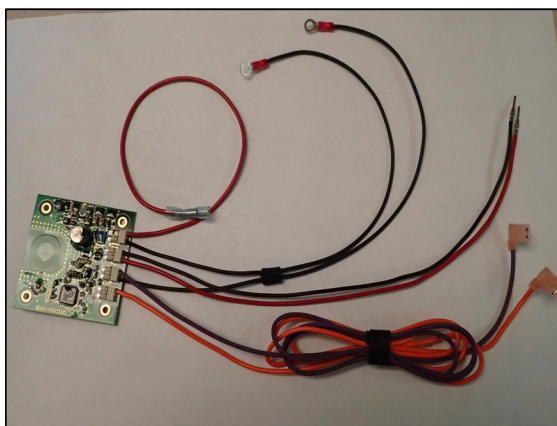
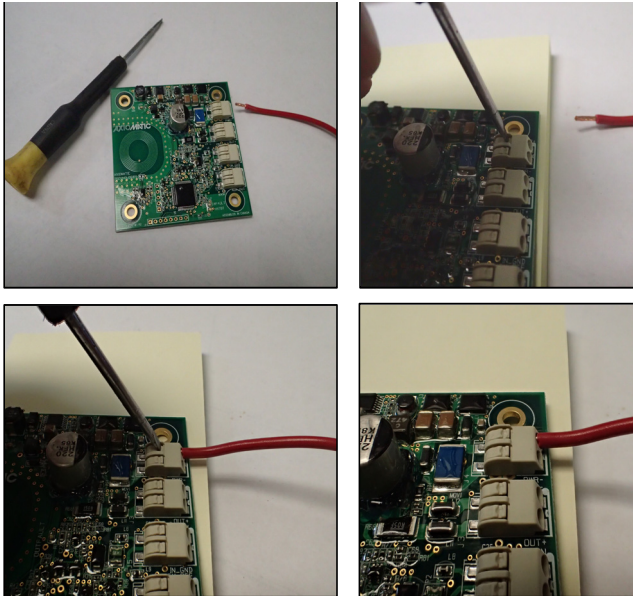

12. Install new driver card using the four (4) removed nuts to the standoffs where the old card was mounted.

CAUTION

Do not over tighten nuts that secure driver card to stand offs inside of control box. If nuts are overtightened, damage and malfunction to driver card will result.



13. Extract wires 1 and 2 in 40 pin connector. Removal of connector may be necessary.

14. Insert wires 051903-03 (BLACK (3) SOLENOID-) into pin location #1.

15. Insert wire 051903-02 (RED (4) SOLENOID+) into pin location #2.

16. Re-install 40 pin connector if removal was necessary.

SECTION 3

Cab Control System

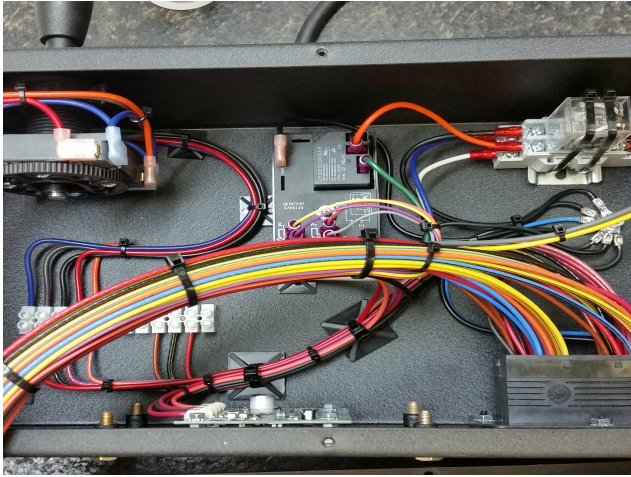

17. Remove and replace wire D (PURPLE wire to PUMP switch VOLTAGE IN) with wire 051903-06 (PURPLE (5) INPUT+).

18. Remove and replace wires C (ORANGE to PUMP switch 5V REF) with 051903-07 (ORANGE (7) +5V REF).

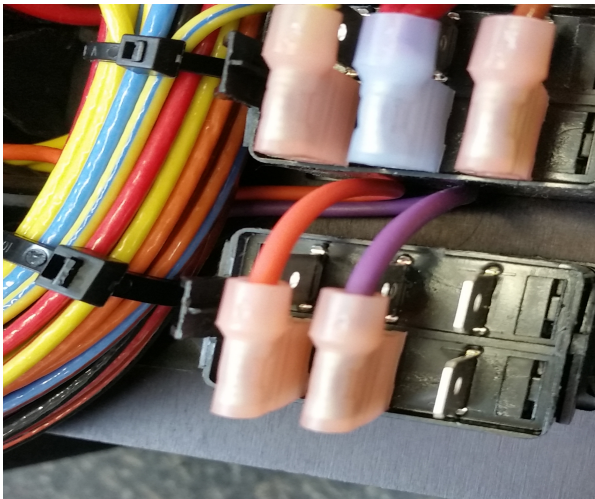

19. Trim wire B (original driver card ground) and secure, this wire will not be used.

20. Attach 2 BLACK wires (051903-04 (2)POWER 9/28 VDC-) and (051903-05 (6)INPUT GND) to ground lug inside of control box.

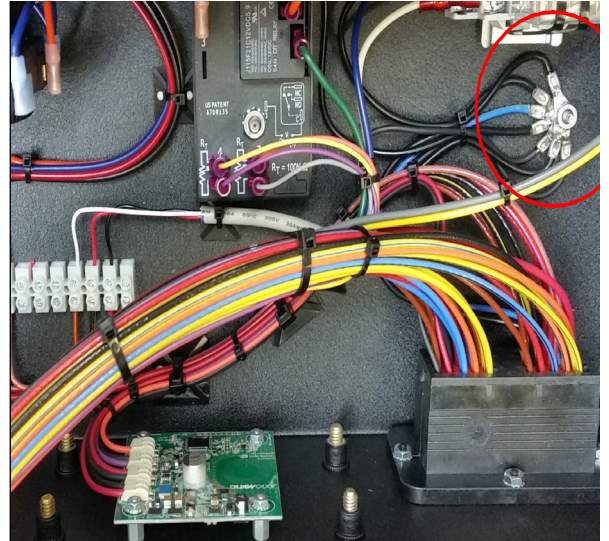

21. Locate RED A wire from old driver card (POWER 9/28 VDC+) route to RED wire 051903-01 (RED (1)POWER 9/28VDC+), trim and strip end, insert into butt splice and crimp. Using heat, shrink butt splice heat shrink and let cool.

22. Organize and secure wiring inside of cab control box using supplied wire ties.

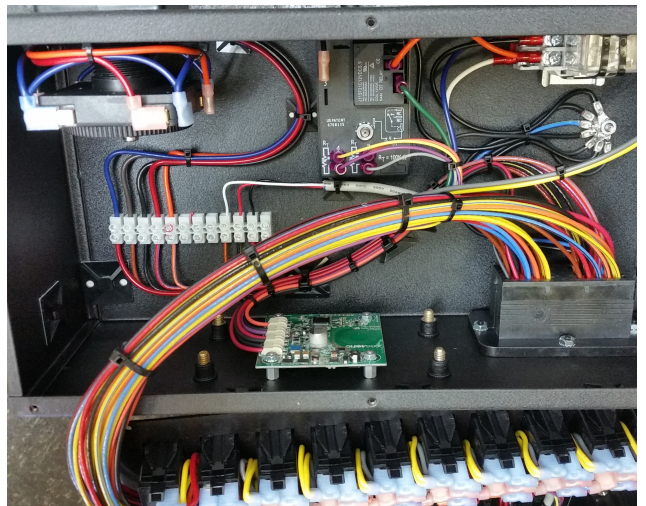

23. Reinstall six (6) screws for face plate.

24. Install cab control box to mount.

SECTION 3

Cab Control System

25. Install 40 pin connector.
26. Restore tractor to operational condition.
27. Fill tank with water.
28. Confirm operation of actuator in normal operation.

DRIVER CARD COMPONENT IDENTIFICATION

(Pre-August 2017 production models) This portion is to identify components and wiring on Driver Card to assist with troubleshooting and replacement. The driver card limits current to hoist coil to prevent potential early failure. The card is preset at MEGA and no field adjustments are recommended.

Solenoid Driver Card

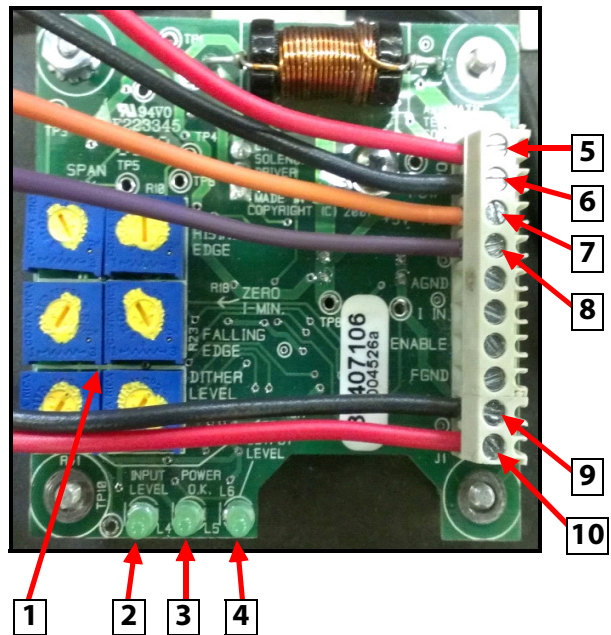

CAUTION

Engaging/disengaging the water pump above LOW IDLE may result in water pump component damage and reduced service life.

CAUTION

If this information is not clear or there is an issue with the update. Contact the MEGA Corp Product Support Group immediately with the water tank serial number at: US toll free: 1-800-345-8889 or Direct 1-505-345-2661.

Item	Description
1	Preset card controls (preset at MEGA)
2	INPUT LEVEL – PUMP switch indication
3	POWER OK – SYSTEM switch indication
4	OUTPUT LEVEL – Signal going OUT to solenoid coil
5	24VDC+ Input from SYSTEM switch
6	GROUND to chassis
7	5V reference voltage to PUMP switch
8	5V reference voltage back from PUMP switch
9	SOLENOID –
10	SOLENOID +

Indicator Led Functions

ITEM 2 - INPUT LEVEL: this LED indicates PUMP switch

SECTION 3

Cab Control System

has been turned ON

ITEM 3 - POWER: this LED indicates SYSTEM power switch has been turned ON

ITEM 4 - OUTPUT: this indicates output signal going to solenoid coil. This LED will go from OFF to partial illumination, gradually indicating that the driver card is ramping and the solenoid coil is slowly engaging. This LED will also indicate a slow ramp to OFF when PUMP switch has been turned OFF.

FIP (Fault Isolation Procedures)

Hoist Valve coil does not engage (NO PUMP operation)

1. Check and ensure 24VDC input on RED wire 40 into control box.
2. Check and ensure SYSTEM fuses are good.
3. Ensure control system GROUND is good.
4. Check and ensure SYSTEM switch and connections are good.
5. Check and ensure solenoid coil is good.
6. Check and ensure solenoid cable connections are good.
7. Check and ensure solenoid cable is good.
8. Check and ensure 24VDC is going to item 5 (POWER) terminal.
9. Check and ensure SYSTEM switch LED illuminates when switch is turned ON.
10. Check and ensure that +5VDC reference voltage to PUMP switch is present (item 7).
11. Turn PUMP switch ON and ensure that +5VDC reference voltage back from PUMP switch is present (item 8).
12. Check and ensure that INPUT LED illuminates and OUTPUT LED illumination steadily grows brighter.
13. Check and ensure 24VDC is present at SOLENOID+.
14. Check and ensure GROUND is present at SOLENOID-.

POWER LED (Item 3) does not illuminate when SYSTEM/POWER switch is turned ON

1. Check and ensure 24VDC is present at SYSTEM/POWER wires entering cab control box.

2. Check and ensure 24VDC is present at SYSTEM/POWER switch.
3. Check and ensure SYSTEM/POWER switch and connections are good.
4. Check and ensure 24VDC is supplied to correct terminals on driver card.
5. Check and ensure driver card terminals are tight.
6. Check and ensure driver card GROUND is good.

INPUT LED does not illuminate when PUMP switch is turned ON (POWER LED is ON, OUTPUT LED is OFF)

1. Check and ensure 5V reference is being supplied from driver card (Item 7) to PUMP switch.
2. Check and ensure PUMP switch and connections are good.
3. Check and ensure hoist valve coil, is good.
4. Check and ensure PUMP cable and connections are good.
5. Check and ensure 5V reference is returning to driver card to Item 8.
6. Verify OUTPUT LED is illuminated.
7. Check and ensure 24VDC power is supplied to host valve coil (Item 10).

POWER and INPUT LEDS are illuminated when SYSTEM/POWER switch is turned ON (OUTPUT LED is OFF, PUMP switch is OFF)

1. Check and ensure hoist valve coil, cable and cable connections are good.
2. Check and ensure driver card terminals are tight and properly wired.
3. Ensure PUMP switch is OFF.

POWER and OUTPUT LEDS are illuminated when SYSTEM/POWER switch is turned ON (POWER switch is ON, INPUT LED is OFF, PUMP switch is OFF, OUTPUT LED is bright)

1. Check and ensure PUMP switch is OFF.
2. Check and ensure system power and ground are good.
3. Check and ensure PUMP cable, connection and coil is good.
4. Check and ensure NO POWER is supplied to hoist valve coil.

SECTION 3

Cab Control System

5. Check and ensure driver card is not cracked or damaged.

Replacement Of Driver Card

1. Remove all electrical power from unit.
2. Disconnect the 40 pin connector from the cab control box.
3. Remove cab control box from mounting platform.
4. Remove six screws from cab control box face panel and carefully flip face panel down to gain access to the driver card.
5. Mark driver card terminal wires to ensure they are reconnected correctly.

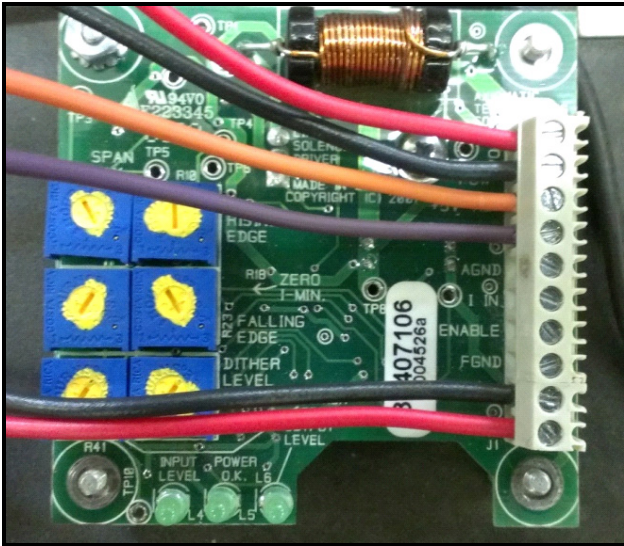

6. Using a thin blade flat tip screwdriver, remove the six (6) wires from the white terminal strip.
7. Remove four nuts that secure driver card to the control box.
8. Carefully remove the card while ensuring the spacer nuts remain on the mount screws.
9. Carefully install new driver card on the four mount screws.

CAUTION

Dropping, bending or crushing of the driver card will damage circuitry and result in card malfunctions.

10. Reinstall and tighten the four retaining nuts to the board.

CAUTION

Over-tightening the retaining nuts will damage board circuitry and result in card malfunctions.

11. Reinstall the six wires in the white terminal strip J1 as previously marked in step 5. Use the table below and the figure on the previous page for reference.

Standard Wiring Schematic

TERMINAL	WIRE COLOR
POW+ (28 VDC +)	RED
POW - (28 VDC -)	BLACK
+5V REF	ORANGE or BLUE
V IN	PURPLE or BROWN
A GND	(NOT USED)
I IN	(NOT USED)
ENABLE	(NOT USED)
F GND	(NOT USED)
SOL-	BLACK
SOL+	RED

12. Secure all wires as required with wire tie straps. Ensure that there are no stray wire strands that may contact the driver card circuit board.
13. Reinstall the control box face panel with the six mount screws.
14. Reinstall the cab control box on the mounting platform.
15. Connect the 40 pin cab control cable to control box.

SECTION 3

Cab Control System

16. Apply electrical power to cab control system.
17. Check water pump operation to ensure water pump engages and disengages properly.

NOTE

If you are having trouble or are in need of assistance please contact MEGA product support with the tank serial number:

US Toll free: 1-800-345-8889
Direct at: 1-505-345-2661

Water Level Gauge Replacement

1. Ensure that the unit is shut off, chocked, and safe for maintenance before proceeding.
2. Remove power to the cab control.
3. Remove cab control face plate to gain access to the backside of the water level indicator.
4. Disconnect the 8 pin connector from the backside of the indicator.
5. Remove the old water level indicator.
6. Install new water level indicator and secure with mount screws. The new water level indicator is a direct replacement for the old water level indicator in terms of installation.
 - a. Reconnect the 8 pin connector to the new water level indicator.
 - b. Reinstall the cab control face plate.
7. Apply power to the cab control box and allow the new indicator to warm up for at least 2 minutes. Perform water level indicator linear calibration.

Water Level Indicator Calibration

NOTE

The term 'swipe' means to move the tip of the calibration magnet tool up to and then away from either the **C 1** or the **C 2** sensor on the front right-hand side of the display:

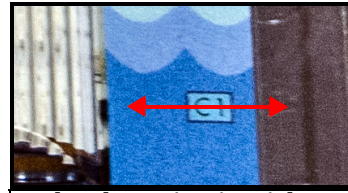

Slowly Swipe in either direction

1. Fill water tank to maximum capacity.
2. Turn SYSTEM ON and allow the system to warm up for at least 2 minutes.
3. Swipe the magnet four (4) times at **C 1** and four (4) times at **C 2** to enter the linear calibration mode.

NOTE

Do not wait more than six seconds in-between swipes, or the session will time out and you will have to start over.

4. Once the calibration code has been entered and linear calibration mode is active, **wait for five seconds**.
5. After five seconds, the top four and bottom four display LEDs should flash alternately on and off to indicate that the code has been accepted. **While the LEDs are still flashing**, hold the magnet steadily at **C 2** for five seconds in order to set the calibration into memory.
6. After a few seconds, the calibration mode will terminate, and all LEDs will illuminate to show that the water tank is at full capacity.

SECTION 3

Cab Control System

7. After performing calibration, **if and only if** the gauge shows 1 or 2 lights LESS than FULL, perform the Full Tank Correction calibration as follows:

a. Swipe the magnet five (5) times at **C 1** and five (5) times at **C 2** to enter the linear calibration mode. The top and bottom five display LEDs should flash on and off.

NOTE

Do not wait more than six seconds in-between swipes, or the session will time out and you will have to start over.

b. Wait three seconds, then hold the magnet tool at **C 2** for five seconds to complete the calibration.

c. After six seconds, the calibration mode will terminate and all of the LEDs should illuminate to show that the water tank is at full capacity.

Water Level Indicator Diagnostic Codes

Using the 9 LEDs in the Primary Display

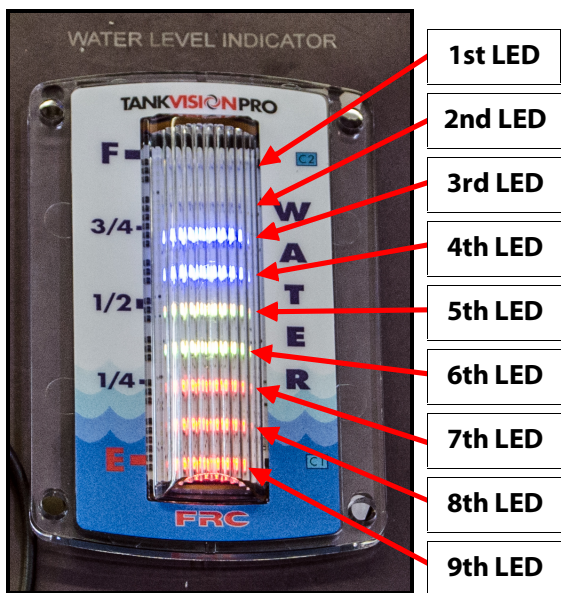

- **Down-chasing LEDs, then bottom two (2) flash**

Indication: Tank EMPTY words
Meaning: Gauge sees an EMPTY tank
Solution: Fill tank with water or repeat CALIBRATION procedure

- **First (1) & last (9) LEDs flash alternately**

Indication: No Sensor
Meaning: No sensor connected, or the sensor is defective, or an OPEN circuit in the sensor wiring
Solution: Check all connections and wiring for damage, or replace cable, or correct connection, or replace sensor, and then repeat CALIBRATION procedure

- **Third (3) & fifth (5) LEDs flash**

Indication: Data Entry Error
Meaning: Calibration was not performed properly
Solution: Repeat CALIBRATION procedure

- **Top four LEDs flash alternately with the bottom four**

Indication: Pressure Sensor High Output Voltage (voltage > 4.6V)
Meaning: Shorted wire on sensor cable or primary display failure
Solution: Check cable for short or replace cable, or replace primary display if no short is present, and repeat CALIBRATION procedure

- **Top 2/3 and bottom 2/3 LEDs alternately flash**

Indication: Memory Failure
Meaning: Primary display failure
Solution: Replace primary display and repeat CALIBRATION procedure

SECTION 3

Cab Control System

Water Level Indicator Display Adjustment

NOTE

The term 'swipe' means to move the tip of the calibration magnet tool up to and then away from either the **C 1** or the **C 2** sensor on the front right-hand side of the display:

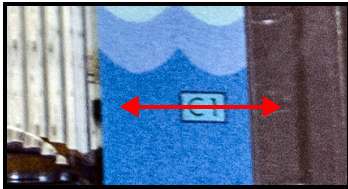

Slowly *Swipe* in either direction

Brightness Adjustment

A light sensor allows the indicator display to switch automatically between the two modes.

NOTE

It is highly recommended to set the brightness levels of both modes to the minimum value (brightness level 1 on a scale of 1-10 with 10 being the brightest) as the default setting is bright enough to induce discomfort.

To adjust day-time brightness (default is 8)

1. Turn SYSTEM ON and allow the system to warm up for at least two (2) minutes.
2. Swipe the magnet three (3) times at **C 1** and one (1) time at **C 2** to enter the linear calibration mode. After a few seconds, the top three LEDs and the very bottom LED should flash on and off.

NOTE

Do not wait more than six seconds in-between swipes, or the session will time out and you will have to start over.

3. Enable brightness setting entry by holding the magnet tool at **C 2** for 5 seconds.

4. Adjust the brightness by swiping the magnet tool at **C 1** until the brightness level reaches its minimum value (1).
5. Save the new brightness setting by holding the magnet tool at **C 2** for 5 seconds.

To adjust night-time brightness (default is 2)

1. Turn SYSTEM ON and allow the system to warm up for at least 2 minutes.
2. Swipe the magnet three (3) times at **C 1** and two (2) times at **C 2** to enter the linear calibration mode. After a few seconds, the top three LEDs and the bottom two LEDs should flash on and off.

NOTE

Do not wait more than six seconds in-between swipes, or the session will time out and you will have to start over.

3. Enable brightness setting entry by holding the magnet tool at **C 2** for 5 seconds.
4. Adjust the brightness by swiping the magnet tool at **C 1** until the brightness level reaches its minimum value (1).
5. Save the new brightness setting by holding the magnet tool at **C 2** for 5 seconds.

SECTION 3

Cab Control System

Color Pattern Selection

The water level indicator display has six (6) total color patterns to select from. The default is Pattern 1:

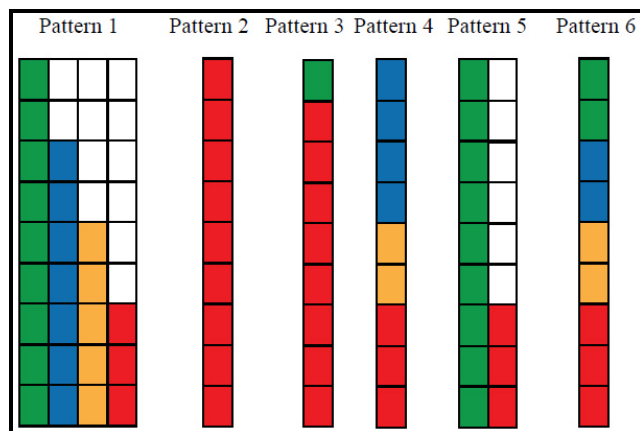

PATTERN 1: One solid color, color changes depending on water level:

- FULL – green
- 3/4 tank – blue
- 1/2 tank – orange
- 1/4 tank – red
- EMPTY – red.

PATTERN 2: All red

PATTERN 3: Top 1/8 water level is green, below that is red

PATTERN 4: Three colors: blue\orange\red

PATTERN 5: All green, turns red when water level is detected to be at or below 1/4 tank.

PATTERN 6: Four fixed colors for each 1/4 tank increment: green\blue\orange\red

1. Turn SYSTEM ON and allow the system to warm up for at least 2 minutes.
2. Select one of the color pattern settings as follows:
 - a. Swipe the magnet one (1) time at **C 1** and one (1) time at **C 2** to select **Pattern 1**
 - b. Swipe the magnet one (1) time at **C 1** and two (2) times at **C 2** to select **Pattern 2**
 - c. Swipe the magnet one (1) time at **C 1** and three (3) times at **C 2** to select **Pattern 3**
 - d. Swipe the magnet one (1) time at **C 1** and four (4) times at **C 2** to select **Pattern 4**
 - e. Swipe the magnet one (1) time at **C 1** and five (5) times at **C 2** to select **Pattern 5**
 - f. Swipe the magnet one (1) time at **C 1** and six (6) times at **C 2** to select **Pattern 6**

NOTE

Do not wait more than six seconds in-between swipes, or the session will time out and you will have to start over.

3. Wait five (5) seconds.
4. After five seconds, the very top LED and between 1-6 (matching the number of times **C 2** was swiped) of the bottom display LEDs should flash alternately on and off to indicate that the code has been accepted. **While the LEDs are still flashing**, hold the magnet steadily at **C 2** for five seconds in order to set the calibration into memory.

SECTION 3 Cab Control System

CAB CONTROL SYSTEM (DISCS® 2.0)



The DiSCS® compact switch pad is based on CAN Bus* protocol and is water and dust resistant. Switch pad LEDs light up in RGB colors which indicate different watering patterns and controls.

- Simple and rugged construction for heavy-duty operations
- Adjustable switch pad brightness
- Fully adjustable RAM® mount (where applicable)
- In-cab water level indicating system
- Total system pause function
- Work light and auxiliary controls

DISCS® 2.0 FEATURES

GPS



Distance and speed based operation modes utilize a GPS based speed signal to automatically stop/start water flow as the vehicle moves.

Manual Spraying



With manual spraying the operator can select each spray head independently and can be used without GPS connection.

Time Based Spraying (Banding)



Operator can cycle on/off periods of spray using selected time intervals.

Distance Based Spraying (Checkerboard)



Alternating intermittent watering patterns reduces water consumption and ensures one steering tire and one drive tire remain on a dry surface.

Speed Based Spraying (Continuous Rate)



speed of travel.

Sequence-based intermittent spray system operation uses PWM (Pulse Width Modulation) to vary the amount of water flow while maintaining a continuous rate of water application, dependent on

SECTION 3 Cab Control System

OPERATION

Start-Up



When the prime mover has the key switch first turned ON, the system performs a self test and will flash all of the switch pad lights.

NOTE

If the switch pads have any buttons that do not light or the flash sequence is different, contact your service department for repair.

NOTE

AGUA BLUE light color is the same as WHITE.

Button Identification



System Power

- Turns system power ON/OFF
- Standby mode - Light OFF
- System ON - Green Light



Water Pump

- Turns water pump ON/OFF
- Standby mode - Light OFF
- Pump ON - Green Light
- Fault - Flash Red/Yellow

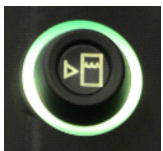

Water Level

- Indicates tank water level
- Greater than 90% - Flash Green
- 90% to 50% - Steady Green
- 50% to 25% - Steady Yellow
- 25% to 5% - Steady Red
- Less than 5% - Flash Red
- Fault - Flash Red/Yellow



Time Based Programming

- Activate the time based program mode
- Standby mode - Light OFF
- Timer Active - Green Light



Speed Based Programming

- Activates speed based program mode
- Standby mode - Light OFF
- Programming ON - Green Light
- No GPS lock - Alternate Red/Green
- Error - Alternate Yellow/Blue



Distance Based Programming

- Activates distance based program mode
- Standby mode - Light OFF
- Program ON - Green Light
- No GPS lock - Alternate Red/Green
- Error - Alternate Yellow/Blue



Auxiliary Function

- Reserved for optional equipment
- Standby mode - Light OFF
- Function ON - Green Light



Left Vertical Spray Head (LT VSS)

- Turns left vertical spray head ON/OFF
- Standby mode - Light OFF
- Open - Green Light

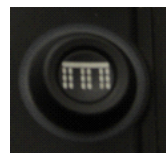

Dump Bar

- Turns dump bar ON/OFF
- Standby mode - Light OFF
- Valve open - Green Light
- Valve closed during time based program - Blue Light



Left Rear Spray Head (LT R)

- Turns left rear spray head ON/OFF
- Standby mode - Light OFF
- Valve open - Green Light
- Valve closed during time based program - Blue Light

SECTION 3

Cab Control System



Left Center Spray Head (LT RC)

Turns left center spray head ON/OFF

- Standby mode - Light OFF
- Valve open - Green Light
- Valve closed during time based program - Blue Light



Rear Facing Work Lights

Turns the MEGA supplied work lights ON/OFF and changes the switch light brightness

- Standby mode - Light OFF
- Light ON - Green Light



WET +

Adjusts spray head Time, Speed, and Distance based programming

- Standby mode - Light OFF



WET -

Adjusts spray head Time, Speed, and Distance based programming

- Standby mode - Light OFF



DRY +

Adjusts spray head Time, Speed, and Distance based programming

- Standby mode - Light OFF



DRY -

Adjusts spray head Time, Speed, and Distance based programming

- Standby mode - Light OFF



Pause

Pauses all active spray functions

- Standby mode - Light OFF
- All pause - Flashing Yellow Light
- All active functions will pause (CLOSE) and switch lights will turn Steady Yellow



Hose Reel

Allows continuous use of hose reel

- Standby mode - Light OFF
- Function active - Flashing Yellow Light
- All other active functions will pause (CLOSE) and switch lights turn Yellow
- Overrides the timeout function



Quick Drain

Turns quick drain ON/OFF

- Standby mode - Light OFF
- Open - Green Light



Right Vertical Side Spray Head (RT VSS)

Turns right vertical spray head ON/OFF

- Standby mode - Light OFF
- Open - Green Light



Right Center Spray Head (RT RC)

Turns right center spray head ON/OFF

- Standby mode - Light OFF
- Valve open - Green Light
- Valve closed during time based program -Blue Light



Right Rear Spray Head (RT R)

Turns right rear spray head ON/OFF

- Standby mode - Light OFF
- Valve open - Green Light
- Valve closed during time based program -Blue Light

Water Pump Time Out Function



After 100 seconds of NO-FLOW conditions (no active discharge function) the water pump will automatically turn OFF (Time out).

Pump Protection Feature

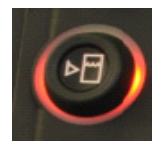

If water level sensor reads water level below 5% for more than 5 seconds, water level button light will flash Red and automatically shut off water pump.

Pause Fault Indication

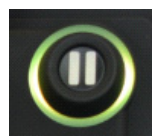

Pressing any function while pause is active will result in a Fault, indicated by Pause and Function buttons flashing Blue/Yellow three (3) times.

Hose Reel Fault Indication

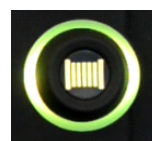

Pressing any function while pause is active will result in a Fault, indicated by Pause and Function buttons flashing Blue/Yellow three (3) times.

SECTION 3 Cab Control System

Control Pad Switch Brightness



Press and hold Work Light button for two (2) seconds (work lights will turn off). The brightness level will cycle down in 25% intervals for every two (2) seconds the button is held. 100% >75%

> 50% > 25% > 100%

Water Cannon Joystick



The water cannon joystick gives the operator complete control of the water cannon system. The water cannon system has options of FAN/FOG adjustable nozzles, as well as fire suppressing foam education.



Water Cannon Butterfly Valve

Turns butterfly valve ON/OFF. Press ON, light under joystick will illuminate at 100% brightness. Press OFF light under joystick will reduce to 20% brightness.



Water Pump

Turns water pump ON/OFF
Press ON/OFF

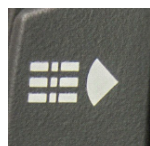

Adjustable Nozzle Stream

Moves nozzle to STREAM position
Press and hold to adjust nozzle



Adjustable Nozzle FAN/FOG

Moves nozzle to FAN/FOG position
Press and hold to adjust nozzle



Foam Agent

Turn foam agent system ON/OFF
Press and hold for 3 seconds to OPEN or CLOSE the foam agent valve.



Pause

Pauses all active spray functions.
Pause - Flashing Yellow

DESCRIPTION

The Program Mode section describes the operation of each program that DiSCS® 2.0 is equipped with. Using the programmed modes ensures ease of use for the operator and consistent spray with reduced chance of over-watering.

TIME BASED PROGRAM MODE



Based on TIME-ON and TIME-OFF settings. (System and Water Pump must be ON for this program mode to activate). Time based programming will control the 4 rear spray heads and the dump bar ONLY, all other

functions will remain in manual selection mode. All other functions can be activated manually while in Time based programming but will not be controlled through the program settings. Time based programming will turn the selected spray heads ON/OFF at the selected time intervals. Pause, Hose Reel, and low water protection are functional in this mode.



Press to advance setting
LONGER wet time (ON)



Press to advance setting
SHORTER wet time (ON)



Press to advance setting
LONGER dry time (OFF)



Press to advance setting
SHORTER dry time (OFF)

SECTION 3 Cab Control System

The time settings available are:

- 3 seconds
- 6 seconds
- 9 seconds
- 20 seconds
- 30 seconds

The four (4) WET/DRY switches advance the timer settings. Every press of the switch will advance the time setting 1 time interval. Select the rear spray heads that are required to activate in this mode

Button Color	Time Cycle
White	3 Seconds
Blue	6 Seconds
Yellow	9 Seconds
Green	20 Seconds
Magenta	30 Seconds

Example:

- Timer is set for 3 seconds ON and 3 seconds OFF, pressing 'WET +' switch one time, the time ON will advance to 6 seconds ON and change the switch color from White to Blue.
- Timer is set for 20 seconds ON and 9 seconds OFF, pressing 'DRY -' switch one time, the time OFF will decrease to 6 seconds and the switch color will change from Yellow to Blue.

SPEED BASED PROGRAM MODE



Vehicle speed input is acquired from the MEGA provided GPS system that relays the vehicle speed to the controller. The controller will determine the watering rate Pulse Width Modulation (PWM) for the selected spray heads. PWM is the pulsing of spray heads to deliver a desired coverage percentage of water that has been selected through the RATE setting. Automatic water reduction will occur before the PWM mode begins, this is when the unit turns OFF the 2 inner spray heads prior based on the SPEED setting selected. As the vehicle speed is reduced the PWM pattern will begin, this is where it pulses the 2 outer spray heads to achieve the requested percentage of water coverage (RATE). (System, water pump and at least one spray head must be on and GPS must have satellite lock.)

Coverage Percentage Setting

Using the 'WET +' and 'WET -' function buttons the operator can adjust the coverage percentage of the Speed Based Program Mode.



Press to advance RATE setting MORE water coverage percentage.



Press to advance RATE setting LESS water coverage percentage.

Button Color	Coverage
White	15%
Blue	30%
Yellow	50%
Green	75%
Magenta	90%

SECTION 3 Cab Control System

Program Speed Setting

Using the 'DRY +' and 'DRY -' function buttons the operator can adjust the MAXIMUM SPEED setting for the Speed Based Program Mode.



Press to advance setting
INCREASE maximum program speed



Press to advance setting
DECREASE maximum program speed

Button Color	Speed
White	8 KPH/5 MPH
Blue	16 KPH/10 MPH
Yellow	24 KPH/15 MPH
Green	32 KPH/20 MPH
Magenta	40 KPH/25 MPH

The speed based program mode will only control the four (4) rear spray heads, all other functions will remain in manual selection mode. All other functions can be activated manually while in Speed Based Programming mode but will not be controlled through the speed based program settings. All selected spray heads OFF at 4.8 kph (3 mph) and less.

Faults:



No GPS Lock - Flashing Red/Green



No connection to GPS receiver -
Flashing Red/Blue

DISTANCE BASED PROGRAM MODE



Vehicle speed input is acquired from the MEGA provided GPS system that relays the vehicle speed to the controller. The controller will calculate the distance to signal the rear spray heads when to turn ON and OFF creating an alternating pattern (checker boarding). This mode can reduce water consumption and control dust while allowing 1 steer tire and 1 drive tire to remain on a dry surface when efficiently set. This mode can be adjusted to spray water most of full width of a haul road in a single pass without crossing the center line. It can produce a wide pattern that can carry over into an adjacent lane when the spray head angles are properly adjusted.

Wet Coverage Distance

Using 'WET +' and WET -' function buttons the operator can adjust the wet coverage distance in the Distance Based Program Mode.



Press to advance setting
LENGTHEN wet strip



Press to advance setting
SHORTEN wet strip

Button Color	Distance
White	15 Meters
Blue	20 Meters
Yellow	30 Meters
Green	45 Meters
Magenta	60 Meters

SECTION 3

Cab Control System

Dry Coverage Distance

Using 'DRY +' and 'DRY -' function buttons the operator can adjust the dry coverage distance in the Distance Based Program Mode.



Press to advance setting
LENGTHEN dry strip



Press to advance setting
SHORTEN dry strip

Button Color	Distance
White	0 Meters
Blue	5 Meters
Yellow	10 Meters
Green	20 Meters
Magenta	30 Meters

Distance based programming will control only the four (4) rear spray heads, all other functions will remain in manual selection mode. All other functions can be activated manually while in Distance Based Programming Mode but will not be controlled by the distance based settings. Distance based programming will turn the selected spray heads ON/OFF at the selected distance intervals. Pause and Low Water protection are functional in this mode. All selected spray heads OFF at 4.8 KPH (3 MPH) or less.

CAB CONTROL SYSTEM (DISCS® 1.5)

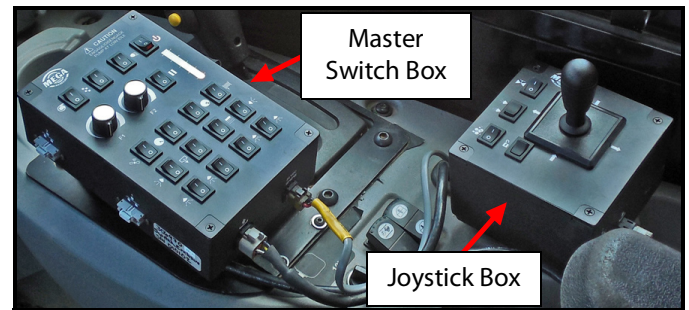











This system is designated as a Digital Spray Control System (DiSCS®). The most recent version is Generation 1.5. The system is comprised of control boxes, controllers, sensors, and cabling. It is a multi-function control system with a separate joystick box that is mounted in the vehicle cab. These two boxes control all water tank functions. The master switch box operates the water pump, spray heads, intermittent spray, work lights, hose reel, dump bar, suction loading, and tank drain valve. The master switch box also provides indications of tanker water level and water pump protection features. The remote mounted joystick box operates the water cannon, adjustable nozzle and foam suppression. The cab controls require 24 VDC vehicle power to operate.

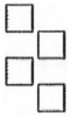

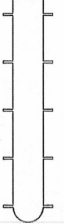



Abbreviations and Definitions

AUX	Auxiliary or additional optional function
BFV	Butterfly Valve
DMPBAR	Dump bar for heavy spray of water close to ground. Can be either a gravity or pressure dump bar (pressure dump bar requires water pump activation to operate).
DRAIN	Drain (gravity or pressure) for evacuation of water from tank, mounted typically at the rear of the tank.
KPH	Kilometers per hour
LT VSS	Left Vertical Side Spray
LTC	Left Center Spray Head
LTR	Left Rear Outer Spray Head
MPH	Mile per hour
RAMP	Ramping Control feature. Rate of increase or decrease in speed of water flow during PUMP engagement or disengagement
RT VSS	Right Vertical Side Spray
RTC	Right Center Spray Head
RTR	Right Rear Outer Spray Head





SECTION 3 Cab Control System

The master switch box control functions operate as follows:

Symbol	Name	Function
	POWER	Provides power for all cab control functions.
	PUMP	Routes vehicle hydraulic system pressure and flow to the water pump hydraulic drive motor.
	INTMNT	Controls activation of either the intermittent mode or the <i>distance-based</i> AUTO mode. See the extended description of "INTMNT" for details.
	LIGHTS	Provides power to work lights.
F1	F1	Function is dependent on the intermittent or AUTO mode settings. See extended description.
F2	F2	Function is dependent on the intermittent or AUTO mode settings. See extended description.
	PAUSE	Pauses all system functions.
	WATER LEVEL	Indicates tank water level. From top to bottom, respectively, the symbols indicate a water level of FULL, 3/4, 1/2, 1/4, and EMPTY.
	AUTO	Controls activation of GPS AUTO mode. See extended description for more details.
	AUX 1	Reserved for user-added option.
	AUX 2	Controls activation of suction load station ONLY.
	HOSE	Controls activation of hose reel function ONLY.
	LT VSS	Opens or closes left vertical side spray head.
	DRAIN	Opens or closes tank drain BFV.

Symbol	Name	Function
	DUMP BAR	Opens or closes dump bar BFV.
	RT VSS	Opens or closes right vertical side spray head.
	LT REAR	Opens or closes left rear spray head.
	LT CTR	Opens or closes left center rear spray head.
	RT CTR	Opens or closes right center rear spray head.
	RT REAR	Opens or closes right rear spray head.

The joystick box functions operate as follows:

	Control	Function
(N/A)	Joystick (LEFT-RIGHT-UP-DOWN)	Sends command signals to the hydraulic control valve assembly to move the water cannon.
	FOAM	Open or closes the foam concentrate tank in-line control valve.
	FOAM LOCK	Unlocks FOAM switch for activation of foam suppression.
	NOZZLE	Adjusts water cannon nozzle from FOG to STREAM.
	BFV	Opens or closes the water cannon butterfly valve.

SECTION 3

Cab Control System

Basic System Theory Of Operation

Spray system power is provided by chassis 12/24 volt DC power. Power is routed to cab control boxes and to the solenoid box controllers by turning on the switched power via the ignition key switch.

When the chassis ignition switch is turned on, the master switch box will undergo a functional self-test. During this process, ALL LEDs will first turn ON, then OFF. While this is occurring, the water level indicator lights will initially register a FULL tank, and will then decrease down to EMPTY. The EMPTY light will blink, and then the water level indicator will count up to register the current water level of the tank. The spray system will function normally when the cab control POWER switch is turned ON and sufficient water is present in the tank (water level EMPTY light not flashing).

Activation of a specific function is accomplished by depressing the appropriate switch on the master switch box or joystick box. This sends a signal to the logic control panel in the solenoid box requesting activation of the associated function. The logic control panel then provides an output command to the associated function coil.

Depressing a switch sends a signal to the logic control panel in the solenoid box to activate the associated function. The appropriate controller in the solenoid box receives the signal and provides output voltage to the given coil. Once voltage is sensed at the coil, the controller sends a signal back to the cab control box to illuminate the LED on the selected function switch.

- If the selected switch LED illuminates, but the component on the water tank is not functioning, then the associated function component (water-way valve, spray head, or water cannon) may have malfunctioned. Contact Mega Product Support immediately.

Water Pump Protection Features

SOFT START AND STOP – The water pump is protected from sudden starts and stops whenever the pump is turned ON or OFF. This protection is implemented in the spray control system by commanding the appropriate proportional hydraulic control valve to open or close slowly. This prevents hard starts or stops that would reduce water pump service life.

LOW WATER PROTECTION – The water pump is automatically turned off when a low water condition is detected. This prevents the water pump from overheating due to running dry.

NO-FLOW CONDITIONS – Whenever ALL water discharge valves are closed, the water pump is automatically turned off after approximately 100 seconds. This feature prevents the water from heating up as a result of the water pump impeller spinning in a sump with no flow. Otherwise, the heating of the static water will also heat the water pump, causing deterioration of grease and premature bearing failure.

NOTE

- If a switch is depressed and the corresponding LED does not illuminate, check to ensure that the POWER switch is ON and the water level EMPTY light is not flashing. If the switch LED still does not illuminate, a malfunction may exist. Contact Mega Product Support immediately at US toll free: 1-800-345-8889, or Direct: 1-505-345-2661.

SECTION 3

Cab Control System

Master Switch Box Extended Function Descriptions



POWER – Turns POWER ON and OFF to cab controls and digital controllers.

NOTE

Before turning the POWER switch OFF, ALL switches must be turned to the OFF position. ALWAYS turn all switches and the POWER switch OFF **before** vehicle shut down.

PUMP – Sends request for pump engagement/disengagement to the appropriate solenoid box controller. The controller will activate the hydraulic circuit to slowly ramp-up or ramp-down the water pump. The water pump switch will flash whenever the switch is on and the following conditions apply:

- Low water condition is sensed (EMPTY LED is flashing).
- No flow condition is sensed (for about 100 seconds no waterway valves are open)

CAUTION

Do not engage/disengage the water pump above LOW IDLE. Engaging/disengaging the water pump above low idle will result in water pump component damage and reduced service life.

PAUSE – Turning this switch ON will pause all spray system functions. Once this switch is turned OFF, spray system functions will resume operation. If the distance-based AUTO mode is active, spray head functions will resume beginning with a dry patch.

- INTMNT** – When the AUTO switch is OFF, turning the INTMNT switch ON activates the Intermittent Mode, in which spray head and dump bar functions are controlled manually by adjustment of the F1 and F2 dials.

When the AUTO switch is ON, turning the INTMNT switch ON activates the *distance-based* checker boarding version of Auto Mode. More details on this mode can be found under “Ground Speed Sensing (AUTO MODE) Control” on page 3-24.

Intermittent Mode

In intermittent mode, spray system functions are controlled by the F1 and F2 dials. Intermittent mode will only operate if at least 1 discharge function (spray head or dump bar) switch is activated. Water discharge can be stopped at any time when in intermittent mode by turning discharge function switches OFF.

The F1 and F2 adjusting knobs command timing as follows:

- **F1** – Adjusts spray head ON time in seconds.
- **F2** – Adjusts spray head OFF time in seconds.

The relationship between dial rotation and ON/OFF time is as follows:

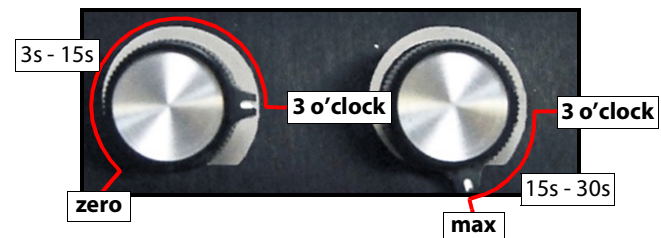

- ZERO TO 3 O’CLOCK POSITION: 3 sec to 15 sec
- 3 O’CLOCK TO MAX POSITION: 15 sec to 30 sec

SECTION 3

Cab Control System

The intermittent mode will turn selected spray heads or dump bar on and off. When a selected function switch (spray head or dump bar) is operating during an ON cycle, the selected function switch LED will be illuminated as well as the Intermittent switch LED. When INTMNT cycles to an OFF cycle, the INTMNT switch and function switch LEDs will extinguish. As the ON cycle is about ready to engage, the INTMNT switch LED will flash 3 times to indicate the selected spray functions are about to be turned ON.

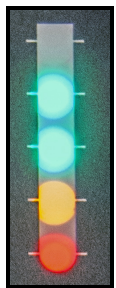



WATER LEVEL INDICATOR – Indicates tank water level. When the red **EMPTY** LED light flashes, the tank is at minimum water level, and the water pump low water protection feature will be activated, as previously described on page 3-18. Water pump operation can only be restored if the tank is above the minimum water level.

NOTE

- In order to re-activate the water pump after low-water shut-off, first fill the water tank with sufficient water capacity to permit pump operation. Then cycle the PUMP switch OFF and back ON.
- Certain terrains and water level fluctuations may allow low water protection to capture a low water level condition, causing the pump to slow to a stop. If conditions allow water pump activation after water level/terrain fluctuations have ceased, then the water pump may be re-activated by following the steps in the previous note.

Pressure Discharge Function Descriptions

 **SPRAY HEADS** – Spray head switches control the opening and closing of the associated spray head valve. The opening and closing of the associated valves is automatically controlled according to the F1 and F2 dial settings when INTMNT or AUTO mode is active.

 **DUMP BAR (PRESSURE)** – Controls opening or closing of the dump bar BFV when selected, or automatically controlled when INTMNT or GPS function is selected.

 **SUCTION LOAD (AUX 2)** – See “AUX 2” description.

Aux Functions

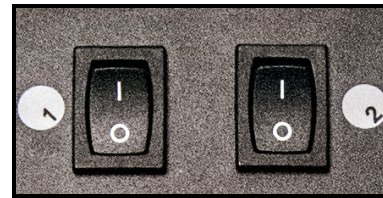

 **AUX 1** – Controls customer-requested optional features. This function is unique to a specific tank serial number.

 **AUX 2 (SUCTION LOAD STATION)** – If equipped, sends a request to the hydraulic water pump drive circuit to allow suction load pump drive motor operation during a low water level condition while also disabling the pump time-out feature. When turned ON, this also disables use of any other spray system function.

 **HOSE** – Allows continuous water pump operation for hose reel use while disabling the use of any other spray system function.

NOTE

Ensure all discharge function switches are OFF when using HOSE function. Activating the HOSE switch requests all discharge function to turn OFF (spray heads, water cannon, drain, dump bar, and foam).

Non-Pressure Discharge Function Descriptions

 **DUMP BAR (GRAVITY)** – Controls opening and closing of the dump bar BFV when selected, or automatically controlled when INTMNT mode or AUTO mode is active.

SECTION 3 Cab Control System

Joystick Box Function Descriptions



The joystick box houses logic controls for the joystick and the FOAM, NOZZLE, and BFV switches. These switches and the joystick control requests for water cannon operation.

 **FOAM** – Sends request for FOAM agent valve to open or close.

NOTE

The FOAM switch is protected by the FOAM LOCK momentary switch. In order to activate FOAM, first press and hold the FOAM LOCK switch. While still holding the FOAM LOCK switch, turn the FOAM switch ON. Hold both switches in the ON position for 1 second and then release.

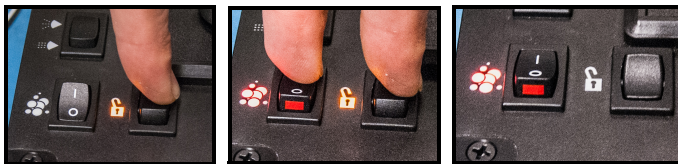

Step 1

Step 2

Step 3

 **NOZZLE** – Sends request for adjustable nozzle on water cannon to move from FAN/FOG to STREAM spray patterns.

 **BFV** – Sends request to open or close the water cannon butterfly valve. This butterfly valve controls water flow to the water cannon. Activating the BFV switch requests the water PUMP to stay ON with NO other pressure discharge functions activated providing that at least the minimum water level is present in the tank.

JOYSTICK – Sends requests for rotation and elevation motion for water cannon operation.

Ground Speed Sensing (AUTO MODE) Control

The MEGA ground speed sensing control system is an independent and self-contained GPS unit that provides speed information to the existing DiSCS®. The DiSCS® logic control uses the ground speed signal to automatically cycle and pulse spray heads to obtain a desired lay-down of water regardless of ground speed. This automatic control reduces water usage and prevents over-watering of haul roads and intersections.

Near or below 4.8 KPH/3 MPH, AUTO mode will switch to INTERMITTENT mode and discharge functions may operate continuously or may ramp down the water pump to OFF. When vehicle speed rises above 4.8 KPH/3 MPH, AUTO will resume control of the system. The system warns the operator of all malfunctioning system functions and provides full manual control of all spray system functions in the event of an AUTO mode failure. All automatic system protection features of low water level conditions, no-flow conditions and water pump soft start/stop feature still operate normally in the AUTO mode.

GPS Extended Function Descriptions

 **AUTO** – This function has priority over intermittent mode. AUTO uses the speed signal from the GPS module to operate the spray system based on **F1** and **F2** adjustments. Pulsed spray (rather than continuous spray) will begin when the AUTO function requests reduced volume.

PWM MODE – If the AUTO switch is ON and the INTMNT switch is OFF, then the AUTO mode is a time-based banding mode, and is adjusted as follows:

F1 – The time for spray head ON cycle. Dial turned counterclockwise **reduces** spray head ON time. Dial turned clockwise **increases** ON time.

SECTION 3

Cab Control System

F2 – This setting dictates the vehicle speed above which all selected discharge functions (spray heads and pressure dump bar) are set for maximum flow. Below this vehicle speed, “reduced volume mode” comes into effect (see description below), and spray heads may pulse on and off rather than spraying continuously.

NOTE

- The scale for this F2 function is 0 KPH/0 MPH (Full LEFT) to 48 KPH/30 MPH (Full RIGHT).
- If the vehicle speed is GREATER than the F2 dial setting, the F1 dial has little or no effect on water discharge. Typically in this case, all requested pressure discharge functions are ON and there is no timing cycle; pressure discharge functions operate continuously.

REDUCED VOLUME MODE – Reduction in discharge volume by reducing the number of spray heads requested to activate.

- If 4 rear spray heads are requested, reduced volume allows only the 2 outer spray heads to turn ON, and the 2 center spray heads are OFF.
- If 3 rear spray heads are requested, 1 spray head will be OFF (typically the center head adjacent to the outer head requested).
- If 2 spray heads are requested, 1 spray head will be OFF (typically the center spray head, unless no center spray heads are requested, in which case NO spray heads will be OFF).

PULSING – Reference to Pulse Width Modulation or ON/OFF cycle.

Distance-Based (Pattern-Based)

If *both* the AUTO and INTMNT switches are ON, then the GPS mode is *distance-based*, or “pattern-based”. Spray head functions operate to create wet and dry patches, the lengths of which are controlled by the F1 and F2 dials, as follows:

F1 – Adjusts the length of the **wet** patches on a linear scale from 10 m (FULL CCW) to 100 m (FULL CW).

F2 – Adjusts the length of the **dry** patches on a linear scale from 10 m (FULL CCW) to 100 m (FULL CW).

NOTE

In **version 4.2 and later**, the minimum length of the dry patch is 0 m, whereas in **version 4.0**, the minimum dry patch length is 10 m. Verify your system’s current firmware version before operating in this mode.

The wet and dry patches will form a checkerboard pattern. The activated left and right spray heads will alternate spraying water to produce wet and dry sections in the following sequence:

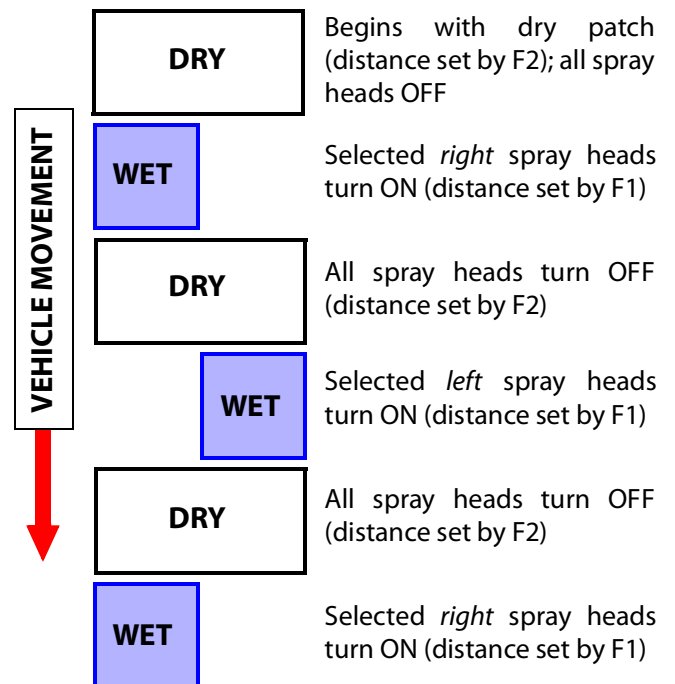

If the system is PAUSED, spray head functions will resume beginning with a dry patch once unpaused.

SECTION 3

Cab Control System

INSPECTION (DIGITAL)

NOTE

For longest component life and safest operation, inspect entire spray system daily.

1. Inspect cab control box(es) for security, damage and function.
2. Check all spray system switches for security and condition.
3. Check water level gauge for proper calibration and operation.
4. Inspect the solenoid box for security, damage, and leaks.
5. Inspect all hosing and fittings for security, damage, and leaks.
6. Wire harnesses for security, damage and condition.
7. Check hydraulic oil filter minder, ensure window shows GREEN, If windows shows RED follow filter service procedure in Section 6.
8. Open solenoid control box access cover and inspect components for the following:
 - a. Solenoid valves for security, damage, and leaks.
 - b. Solenoid control coils and wiring for security, damage and condition.
 - c. Manifold assemblies for security, leaks and cracks.
 - d. All fittings and hoses for security and leaks.
 - e. Pressure reducer for security and leaks.
 - f. Wire terminals and wiring for security, damage and condition.
 - g. **If equipped:** Check controller modules for security, damage and function.
 - h. **If equipped:** Check GPS antenna, mount and wiring for security, damage and condition.
9. Inspect spray heads for security, damage, leaks and debris stuck in adjustment ring.

10. Check all spray system functions for proper operation.

11. **If equipped:** Check water cannon and control for security, damage and leaks.

12. Check water cannon for proper operation.

REPAIR (DIGITAL)

Removing And Replacing DiSCS® Joystick Box And Switch Box

This procedure applies to some boxes that are not equipped with mounting stud and is required when removing and replacing joy stick box and main switch box from the DiSCS® spray system mounting plate.

CAUTION

Follow all instructions below carefully. If these instructions are not followed, damage to the circuit board inside will occur and system failure will result.

1. Ensure all of the spacing washers are kept when replacing joy stick box and switch box on mount.

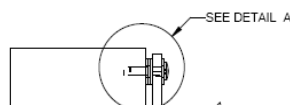
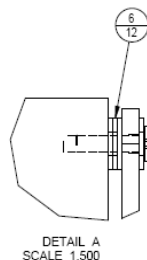
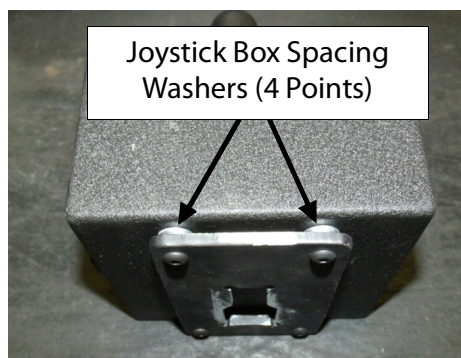

SECTION 3 Cab Control System

2. Ensure the use of #10 x 0.50" x 32 screws.



3. Omit washer under head of screw.



4. The spacing washers are #10 and there must be 3 under each mounting point of the joy stick box.

5. Ensure the minimum dimension is held, to prevent damage to the circuit board inside of box (0.144" or 3.65 mm).



CAUTION

If you are having trouble understanding the procedure contained in this document, immediately contact the MEGA Corp. Product Support Group at:

US Toll free: 1-800-345-8889

Direct: 1-505-345-2661

Or visit our website at www.megacorpinc.com for more detailed contact information.

DiSCS® Switch Replacement

The following is the procedure for replacement of a switch in the main switch box and/or the joy stick box. The illustrations in this text will describe the main switch box switch replacement procedure.

CAUTION

This procedure must be followed to reduce the potential for damage to the box and components contained in the box. Failure to follow this procedure will result in component damage and spray system malfunction.

SECTION 3 Cab Control System

Switch Replacement Procedure

1. Secure unit. Ensure unit is safe for service.
2. Locate replacement switch.
3. Using a Phillips head screwdriver, remove four (4) screws holding cover on box.



4. Lift off the cover. Using needle nose pliers, pull the three (3) electrical connectors off of the switch.

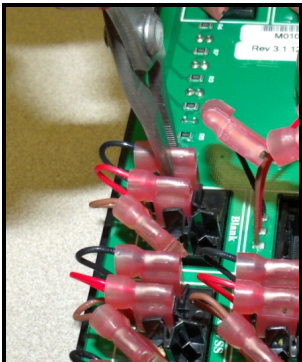

5. Using a small flat blade screwdriver, carefully pry switch from cover plate.

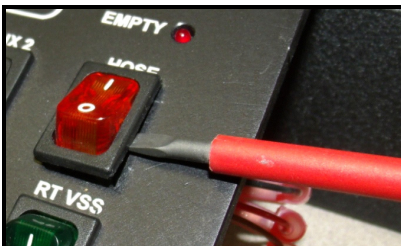

6. Remove and replace switch, place switch in position and press firmly to seat switch on cover plate.

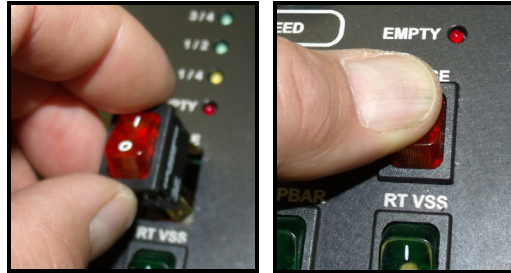

7. Place electrical connectors on switch terminals in the same order they were removed. Ensure connector is fully seated on terminal.

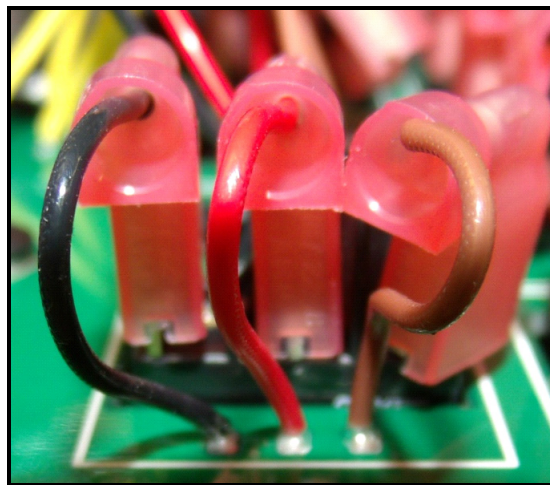
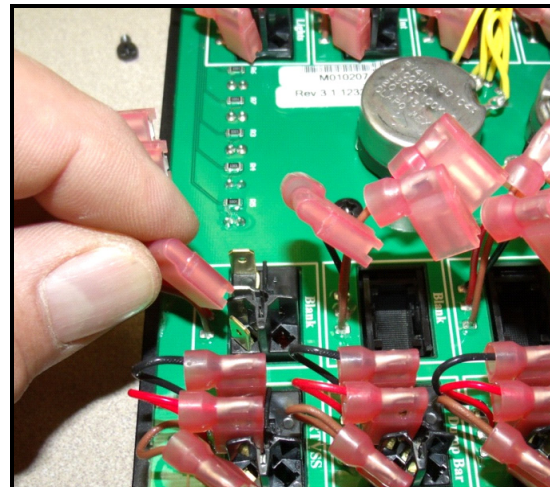

8. Carefully place cover plate on box. Ensure ribbon cable and other wiring is not pinched under cover.

SECTION 3

Cab Control System

9. Install four (4) cover plate screws.

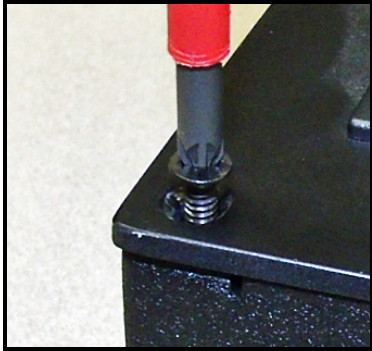

10. Remount control box to pedestal.

CAUTION

- When re-installing joy stick box to mounting plate, ensure the procedure for “removing and replacing joy stick box” is followed. Failure to follow procedure will result in component damage and failure.
- If you are having trouble understanding the procedure contained in this document, immediately contact the MEGA Corp. Product Support Group.

DiSCS® Gen. 1.5 Switch Replacement

The following is the procedure for replacement of a switch in the Gen. 1.5 main switch box and/or the joy stick box. The illustrations in this text will describe the main switch box switch replacement procedure.

CAUTION

This procedure must be followed to reduce the potential for damage to the box and components contained in the box. Failure to follow this procedure may result in component damage and spray system malfunction.

1. Secure unit. Ensure unit is safe for service.
2. Locate replacement switch.

3. Using a Phillips head screwdriver, remove the four (4) box cover screws. Lift off the cover.

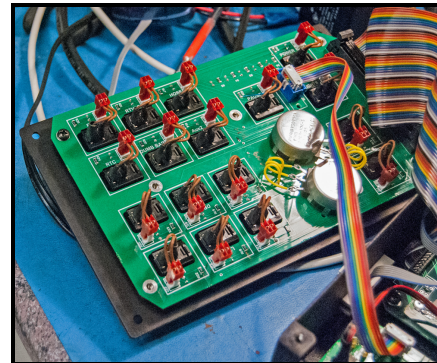

4. Disconnect the switch to be replaced as shown:

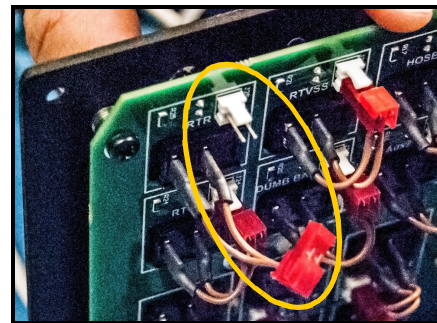

5. There are two lock tabs (one each at the top and bottom of the switch) securing each switch to the cover. Using a small flat blade screwdriver, depress and unlatch both lock tabs to release the switch.

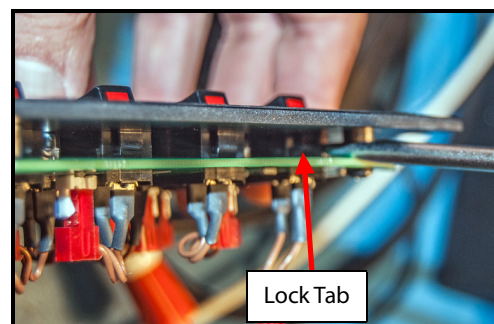

NOTE

It may be necessary to remove adjacent switches in order to reach the switch that needs replacing.

SECTION 3

Cab Control System

6. Remove the switch from the cover plate.

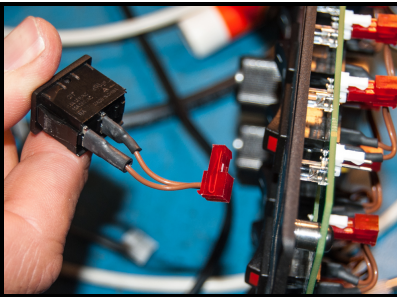
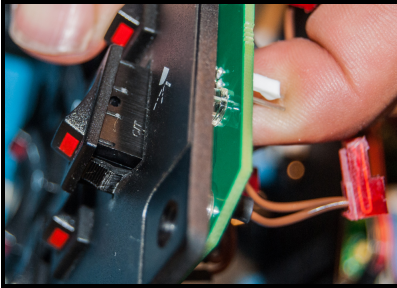

7. Install replacement switch. Place switch in position and press firmly to seat switch on cover plate. Reconnect switch to the circuit board.

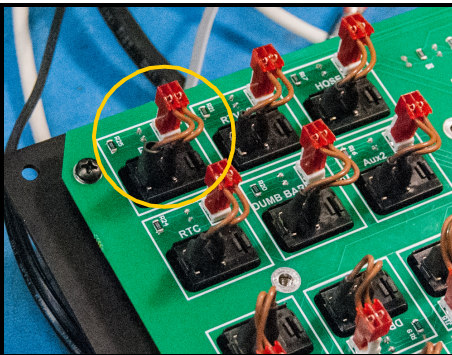

8. Carefully place cover plate on box. Ensure ribbon cable and other wiring is not pinched under cover.

9. Install four (4) cover plate screws.

CAUTION

If you are having trouble understanding the procedure contained in this document, immediately contact the MEGA Corp. Product Support Group.

Controller Fuse Replacement Procedure

This procedure is to be followed when the Troubleshooting procedures have indicated that a fuse in a controller needs to be replaced.

1. Secure unit. Ensure unit is safe for service.
2. Locate controller where suspected fuse is located.
3. Using a Phillips head screwdriver, remove two (2) screws on connector end of controller.

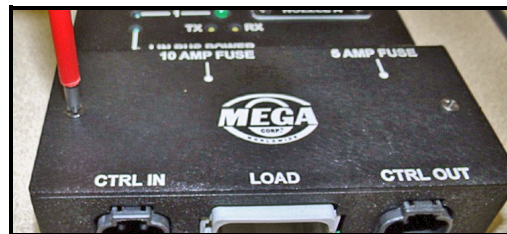

4. Using needle nose pliers, grasp suspected fuse and remove from fuse holder.

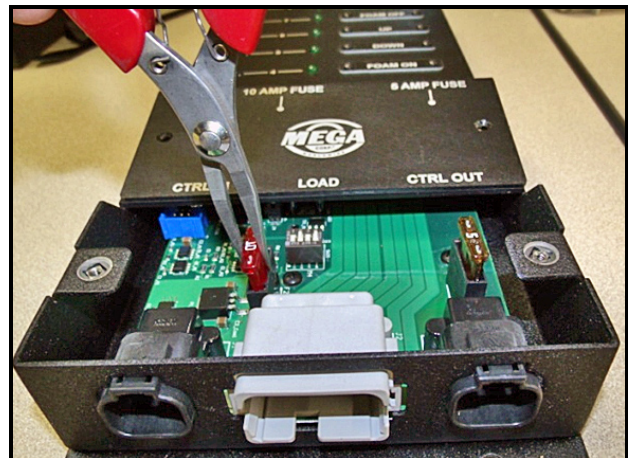

SECTION 3

Cab Control System

- Inspect fuse to ensure fuse is bad. If fuse is bad, replace fuse with fuse of same amperage.

CAUTION

When replacing fuses, ensure the same amperage rating is used. Replacing a fuse with a higher amperage rated fuse will result in component, wiring or controller failure. Ensure same amperage rating is used. Blown fuses indicate a component is drawing a higher than rated amount of current, which could indicate a short circuit or a defective component that needs repairing or replacing. Ensure root cause of blown fuse is repaired.

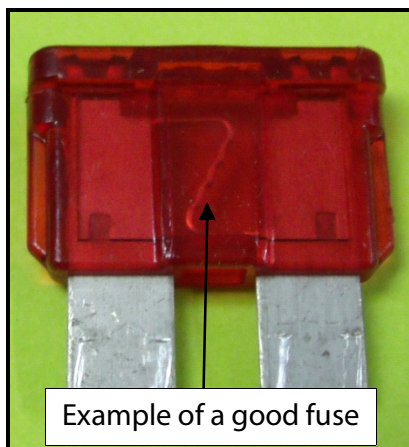

- Insert new fuse into fuse holder and press firmly until seated.
- Install two (2) screws and cover on controller.
- Ensure fuse replacement corrected suspected problem.

CAUTION

If you are having trouble understanding the procedure contained in this document, immediately contact the MEGA Corp. Product Support Group at:

US Toll free: 1-800-345-8889

Direct: 1-505-345-2661, or visit our website at www.megacorpinc.com for more detailed contact information.

Coil Replacement

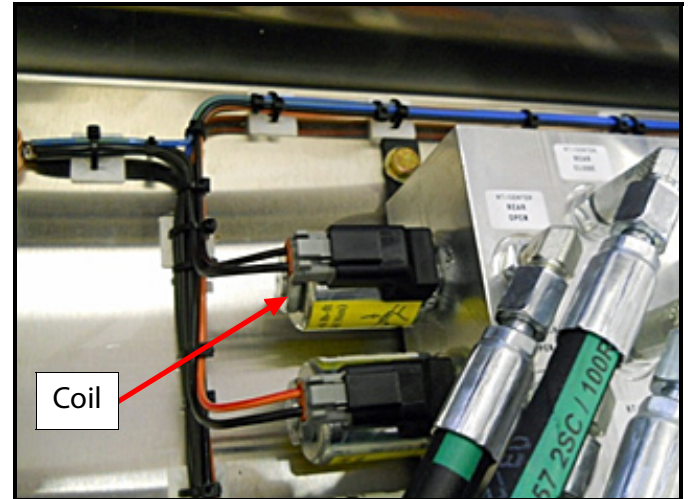

- Remove all hydraulic pressure from the vehicle hydraulic system.
- Remove all electrical power from the spray system.
- Open solenoid control box cover and mark coil wire locations.
- Remove wiring from solenoid.
- Remove old coil and install new coil. Torque coil/solenoid retaining nut to 4-6 ft lbs. (6 – 8 nm).
- Attach new coil wires to the previously labeled locations.
- Secure wiring harness.
- Perform full functional check of the spray system component replaced.
- Close solenoid control box cover.

CAUTION

If you are having trouble understanding the procedure contained in this document, immediately contact the MEGA Corp. Product Support Group.

SECTION 3

Cab Control System

Solenoid Valve Cartridge Replacement

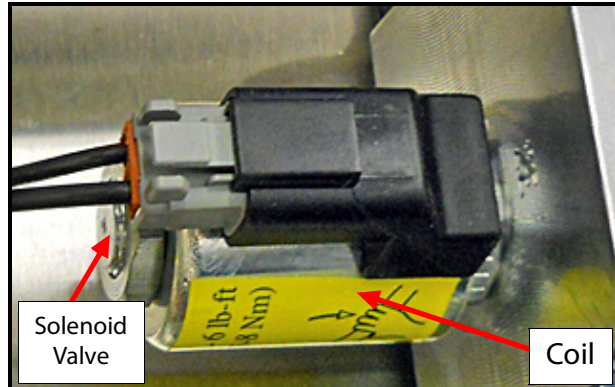

1. Remove all hydraulic pressure from the vehicle hydraulic system.
2. Remove all electrical power from the spray system.
3. Open solenoid control box cover and mark coil wire locations.
4. Remove coil.
5. Remove solenoid cartridge from hydraulic manifold.
6. Lubricate O-rings on new solenoid cartridge.
7. Install new solenoid cartridge with O-rings into manifold.
8. Reinstall coil and torque retaining nut to 4 - 6 ft lbs. (6-8 nm).
9. Apply hydraulic pressure to the spray system and check solenoid valve for leaks.
10. Perform full functional check of the spray system component replaced.
11. Close solenoid control box cover.

12. Service vehicle hydraulic system as required.

CAUTION

If you are having trouble understanding the procedure contained in this document, immediately contact the MEGA Corp. Product Support Group.

Pressure Relief Valve Replacement

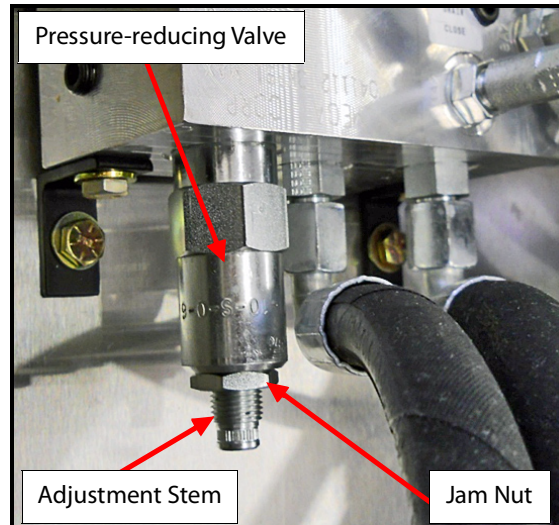

1. Remove all hydraulic pressure from the vehicle hydraulic system.
2. Remove all electrical power from the spray system.
3. Open solenoid control box cover to gain access to pressure relief valve.
4. Remove old pressure relief valve.
5. Lubricate new pressure relief valve.
6. Install new pressure relief valve.

CAUTION

Pressure relief must be set to no more than 600 PSI (4,100 kpa). Higher pressure settings will allow spray heads to open and close rapidly and cause water to hammer of the water pump system. Continued water hammering will cause damage to water pump system.

SECTION 3

Cab Control System

7. Install in-line pressure gauge on one of the spray head close port to observe system pressure for adjustment of the pressure reducing valve.
8. Loosen pressure reducing valve jam nut and insert Allen wrench in the pressure reducer adjustment stem.
9. Apply hydraulic and electrical power to the spray system.
10. Note system pressure at gauge.
11. Adjust pressure reducing valve stem to set 550 PSI (3,800 kpa). Tighten jam nut.
12. Perform full operation check of all hydraulic spray system functions.
13. Close solenoid box cover.
14. Shutdown spray system and service vehicle hydraulic system as required.
15. Remove hydraulic pressure gauge from spray head and reconnect hydraulic hose.

CAUTION

If you are having trouble understanding the procedure contained in this document, immediately contact the MEGA Corp. Product Support Group at:

US Toll free: 1-800-345-8889

Direct: 1-505-345-2661

Or visit our website at www.megacorpinc.com for more detailed contact information.

Hydraulic Oil Filter

1. Check control box hydraulic filter minder for restriction with engine running. If **GREEN**, then the system is OK.

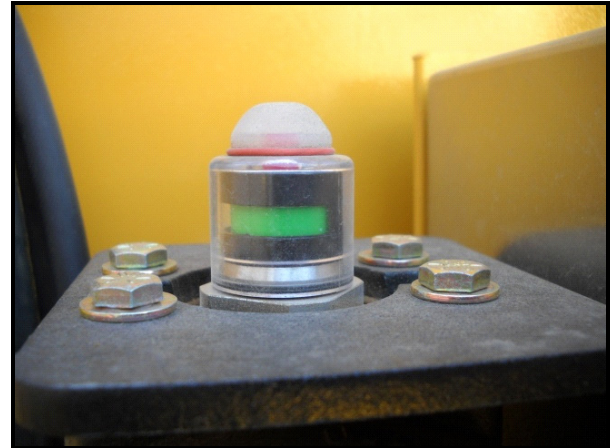

2. If filter minder is **RED**, then filter **SERVICE IS REQUIRED**.
3. Service/clean hydraulic filter as follows:
 - a. Remove hydraulic pressure from control system and make unit safe for service.
 - b. Properly drain and dispose of oil from filter housing.
 - c. Remove filter element from housing
 - d. Remove external build-up of contamination with cleaning fluid in separate tank.

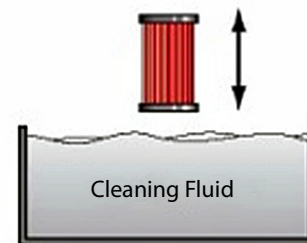

- e. Remove large particles in the pleats using a rounded needle or tweezers.

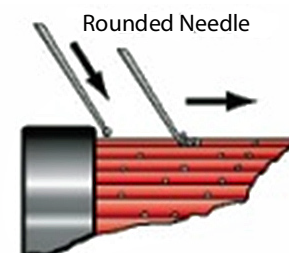

SECTION 3 Cab Control System

- f. Immerse the element for 30 minutes in high quality cleaning fluid.



- g. Flush from the inside with air-water pistol.

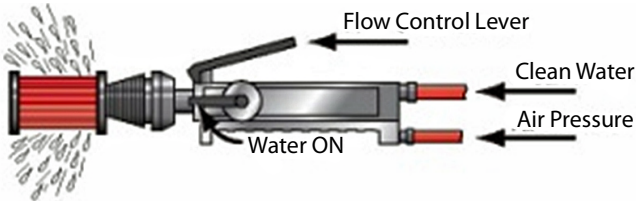

- h. Turn off water and blow from inside with air only.

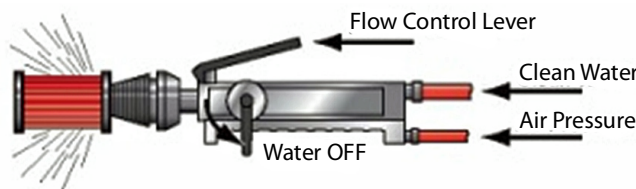

- i. Immerse in isopropyl alcohol to remove the remaining water particles.



- j. Allow element to dry. Then pack element in airtight plastic bag for future use.

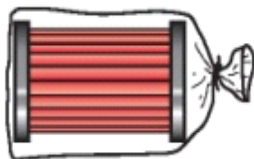

4. Re-install cleaned filter element or install new filter element in filter head. Lubricate new O-ring with clean system fluid.
5. Use twisting motion to prevent O-ring damage when installing filter element.
6. Screw filter housing into filter head.

CAUTION

Filter housing in filter head must be hand tightened only. Over-torquing filter housing will result in damage to O-rings, filter head and filter housing.

7. Pressurize system and check for leaks.
8. Ensure filter minder indicator is **GREEN**.

CAUTION

If you are having trouble understanding the procedure contained in this document, immediately contact the MEGA Corp. Product Support Group at:

US Toll free: 1-800-345-8889

Direct: 1-505-345-2661

Or visit our website at www.megacorpinc.com for more detailed contact information.

SECTION 3

Cab Control System

CONFIGURATION & PROGRAMMING, GEN 2.0

This document has been created to guide a technician through the configuration process of the new MEGA DiSCS® 2.0 Spray System. This information will require the technician to measure the water tank height and confirm the tank options.

Tools Required:

Windows based laptop computer

- MEGA Supplied ECOM driver and FX Service tool software on thumb drive or Emailed (installed on laptop)
- 309025 – ECOM cable DiSCS® 2,0
- Measuring tape (Requirement is in inches of water)
- MEGA DiSCS® 2.0 spray system installed on operational chassis (System power will be required to configure spray system)
- Small pocket screwdriver (to remove and insert switch cover icons)

Procedure

1. Insert MEGA Supplied thumb drive and copy the 2 service tools (ECOM Drivers and FX Service Tool) to the laptop.

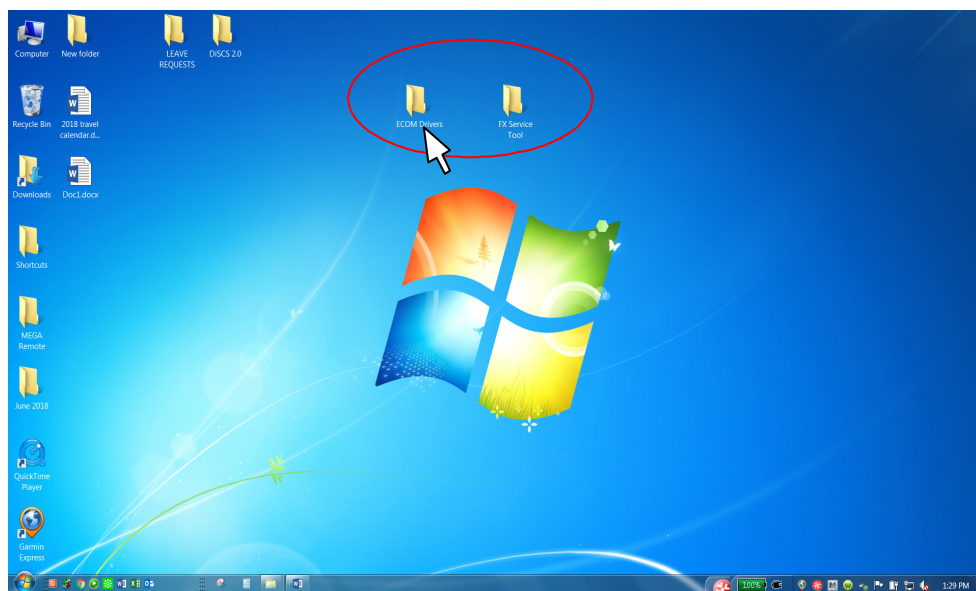
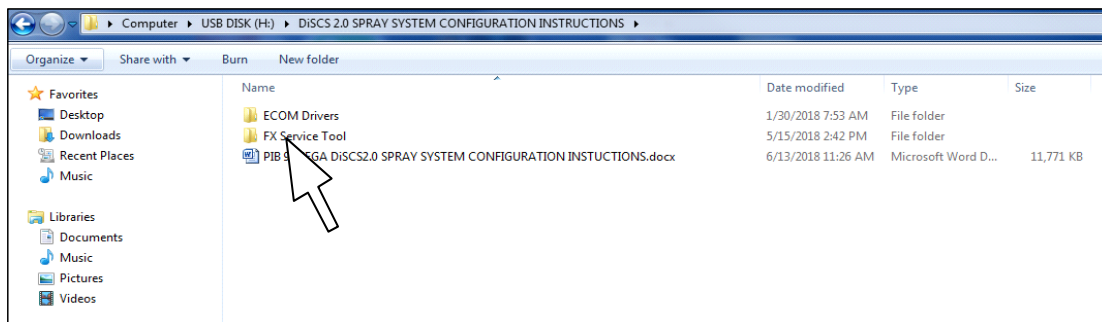

SECTION 3 Cab Control System

2. Open the ECOM Driver folder, click the Driver_Setup.exe file and follow the installation instructions.

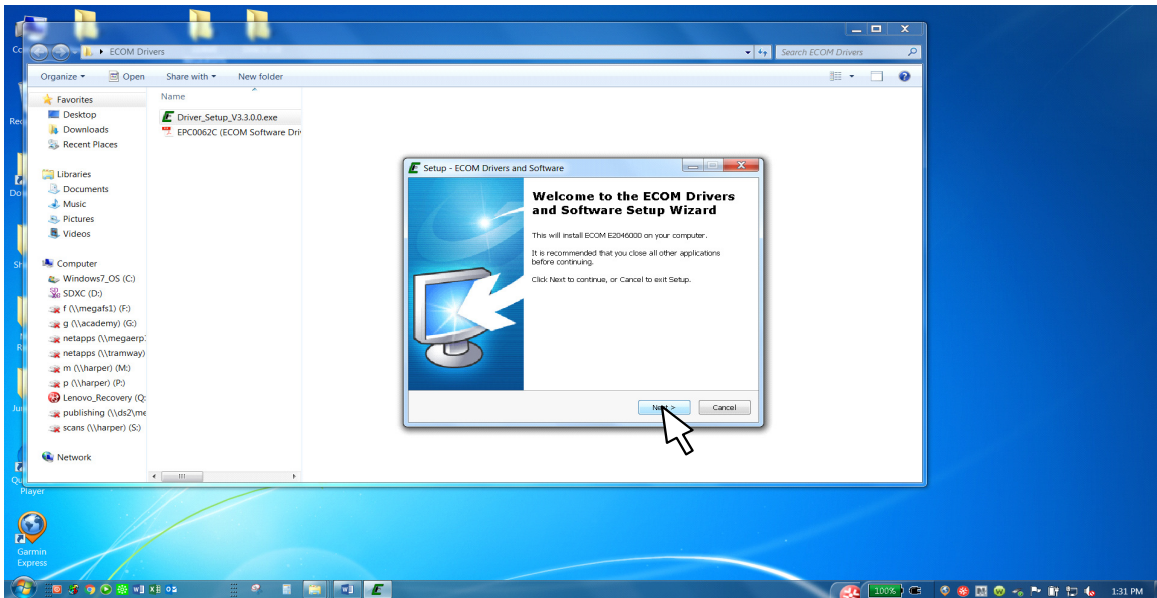
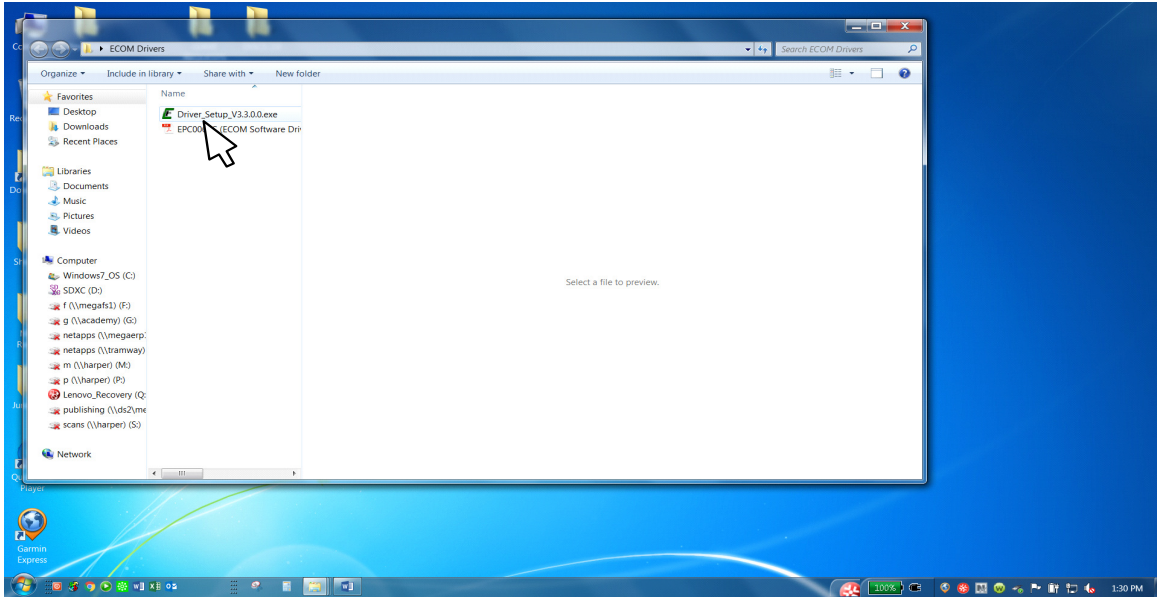

SECTION 3 Cab Control System

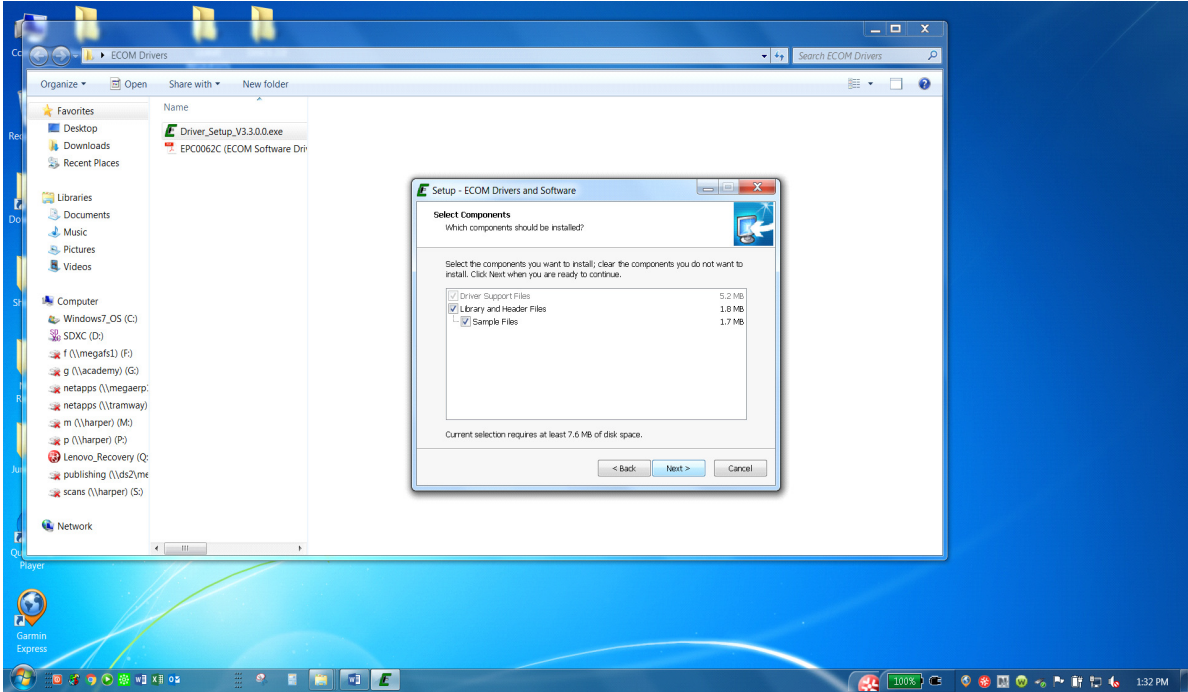
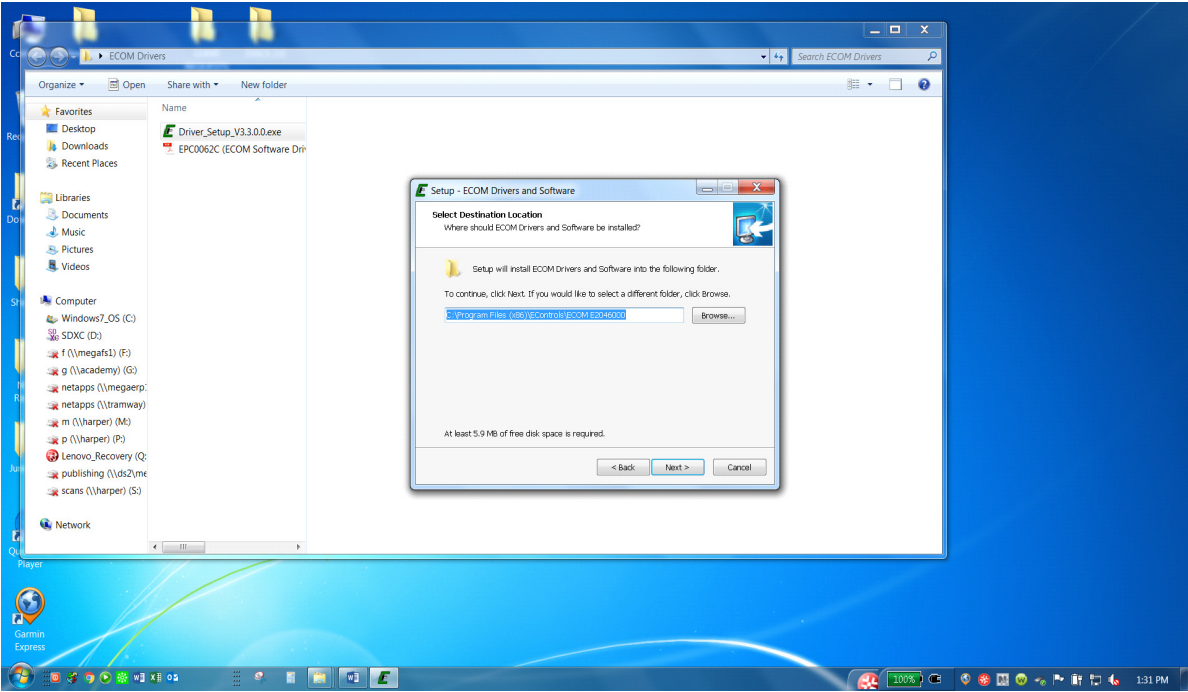

SECTION 3

Cab Control System

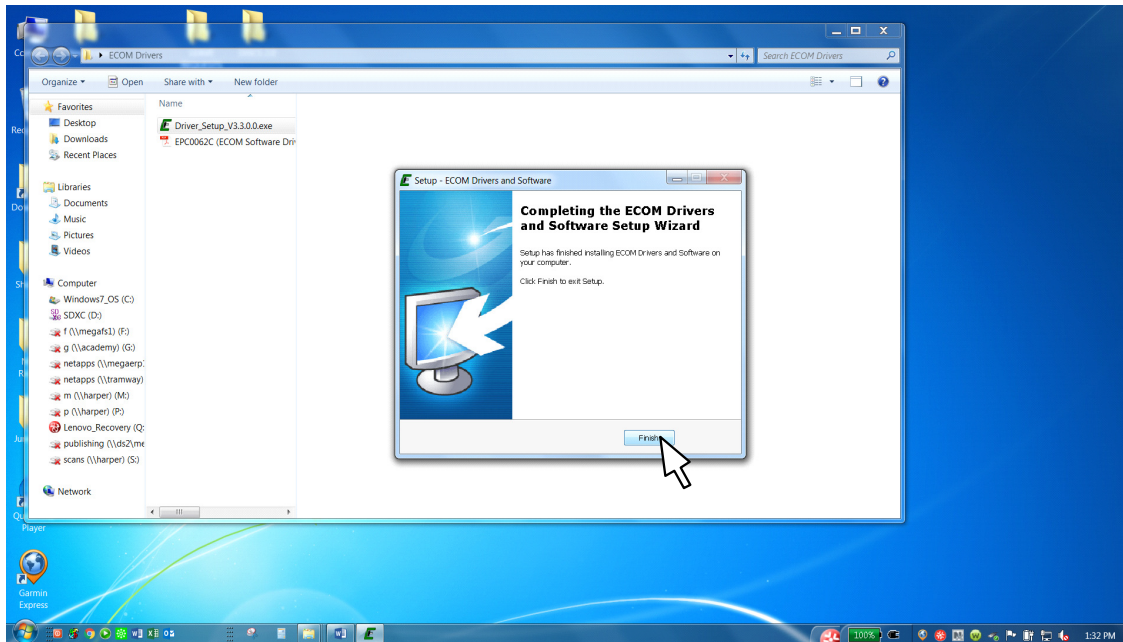
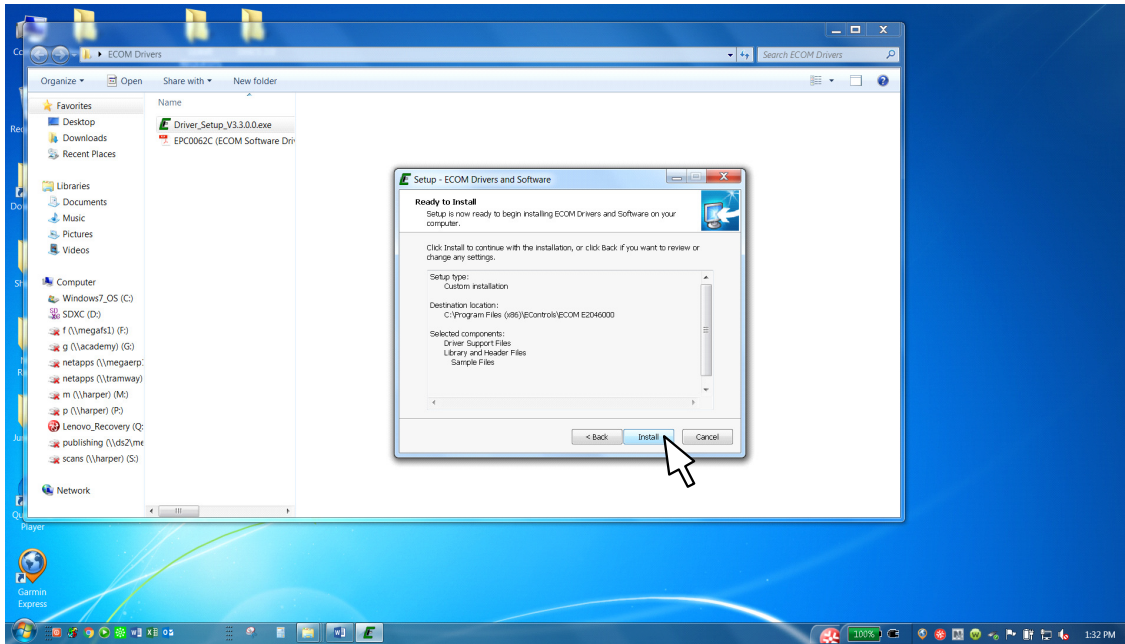

SECTION 3 Cab Control System

3. Open the FX Service Tool folder.

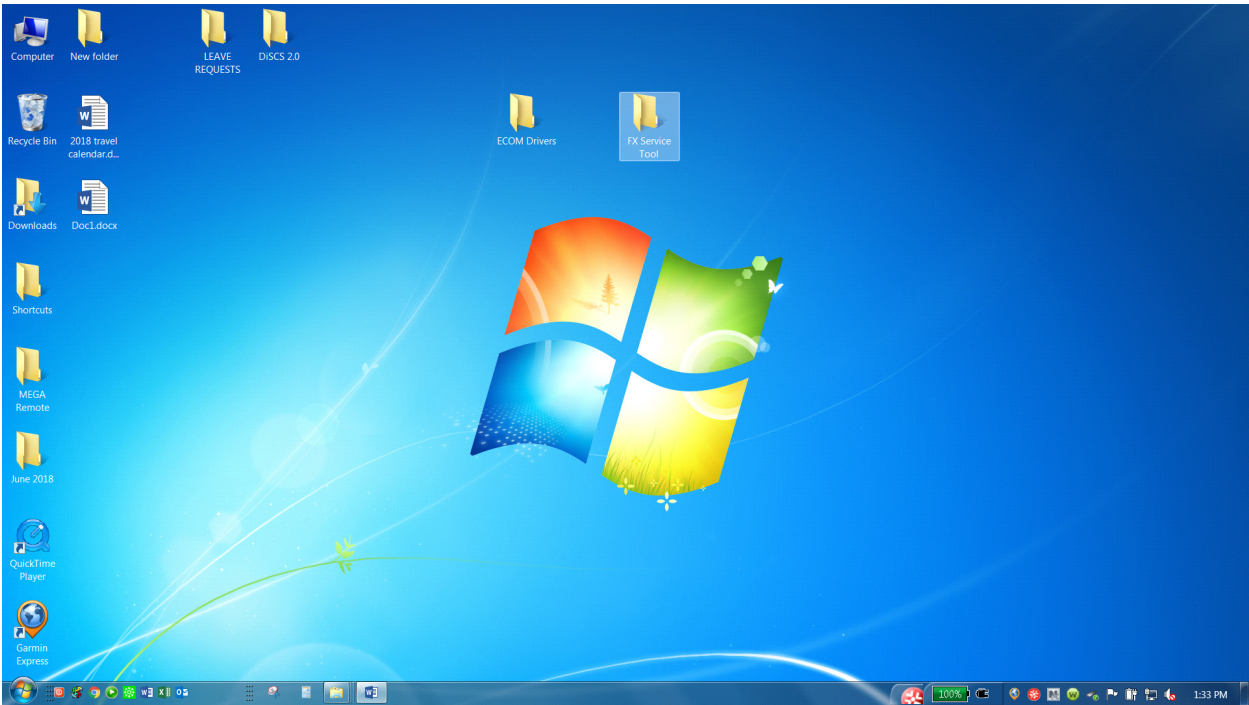

4. Click on the nw.exe file.

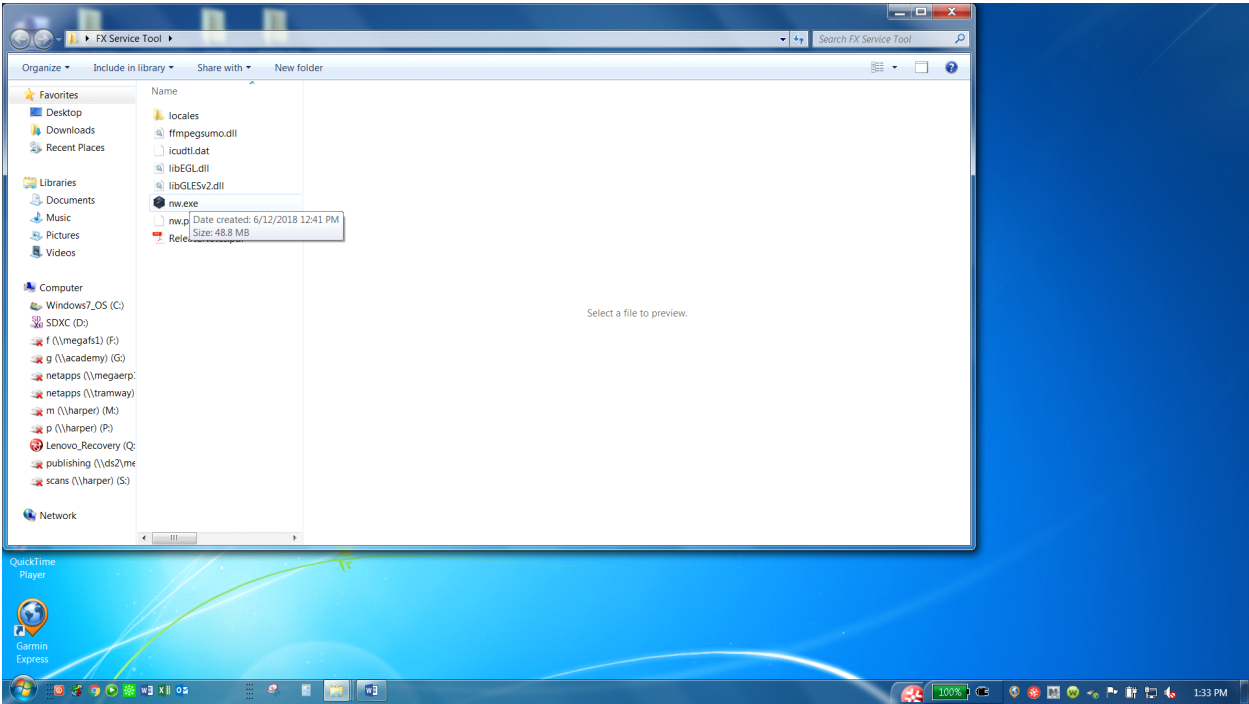

SECTION 3 Cab Control System

5. The Service Tool is now ready to use.
6. Close all windows and plug the ECOM cable into a USB port on the laptop.

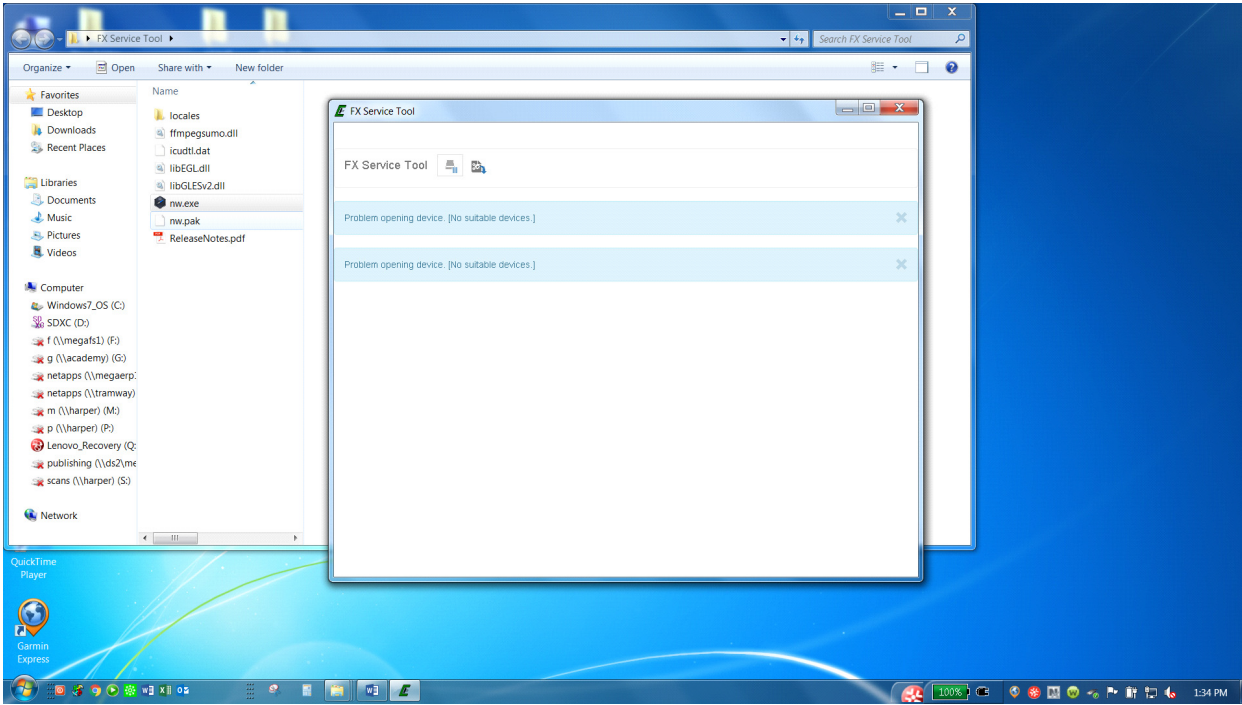

7. Turn laptop computer ON.
8. Remove dust plug from Controller Service Tool Port.
9. Plug ECOM service tool into 6 pin connector on spray system controller (inside of solenoid box lid).

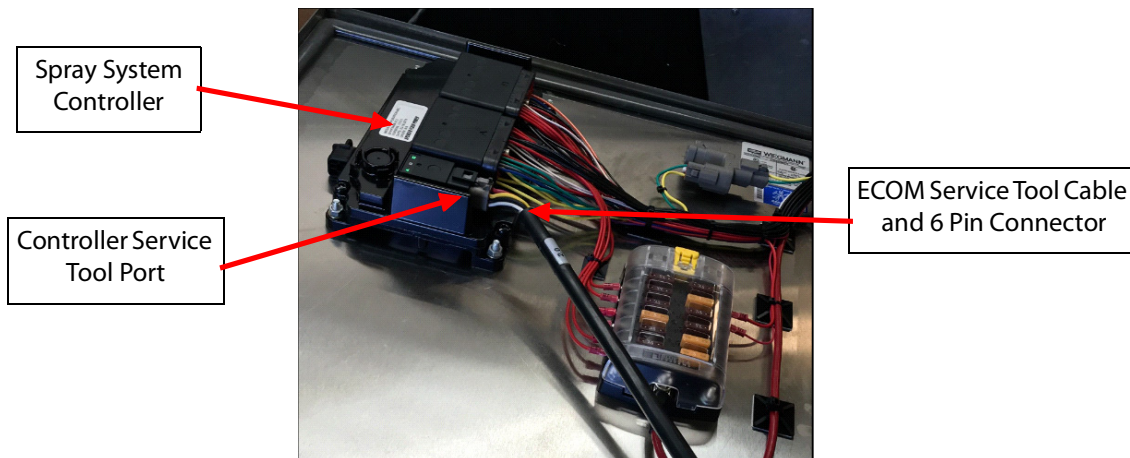

SECTION 3 Cab Control System

- 10. Turn tractor power ON.
- 11. Turn DiSCS® 2.0 Spray System power ON.
- 12. The switch light will turn green.

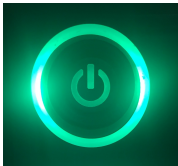

- 13. Click on the FX Service Tool folder and click the nw.exe file to open the ECOM service tool.

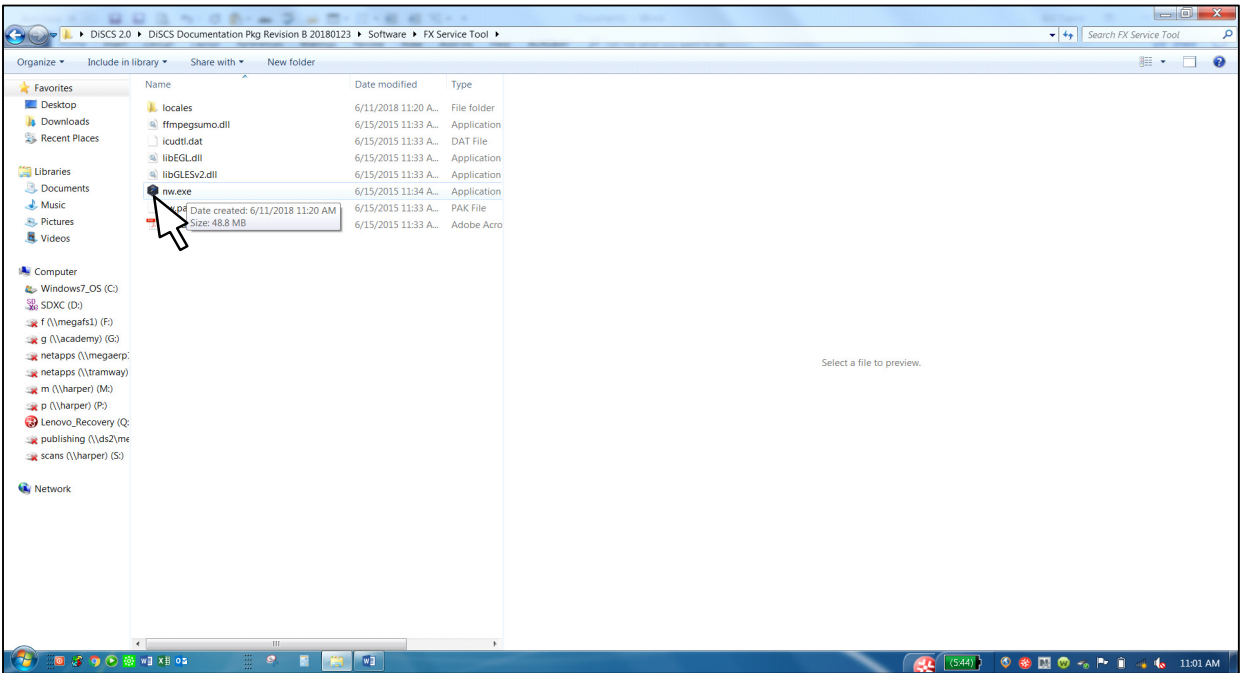

- 14. The service tool is now operational.
- 15. Click on the ParameterData expand icon.

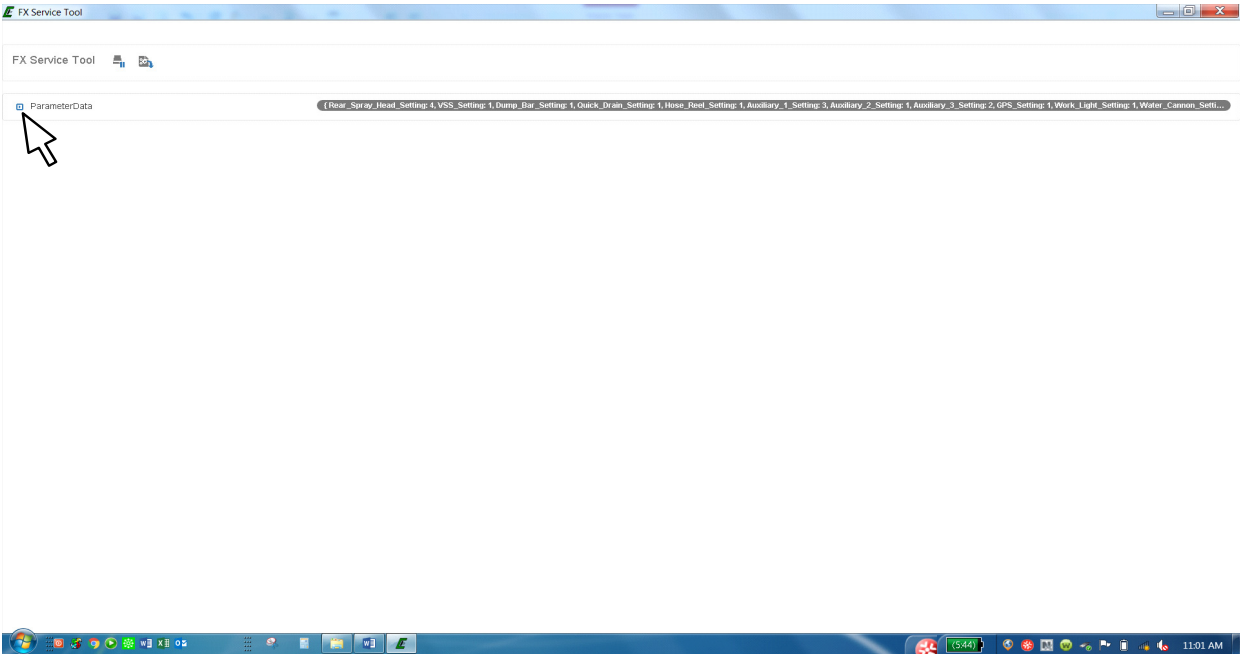

SECTION 3

Cab Control System

16. With the configuration menu expanded, you can begin the configuration of the spray system.

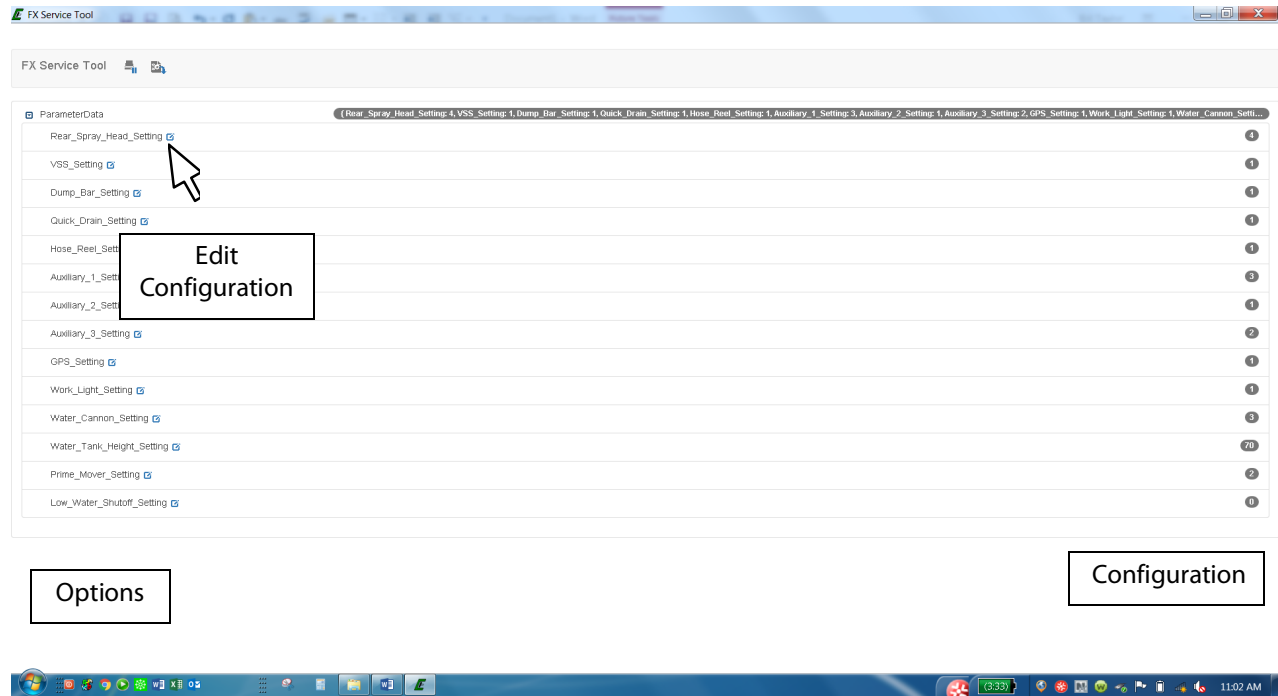

SECTION 3 Cab Control System

17. Example of spray system configuration line code:

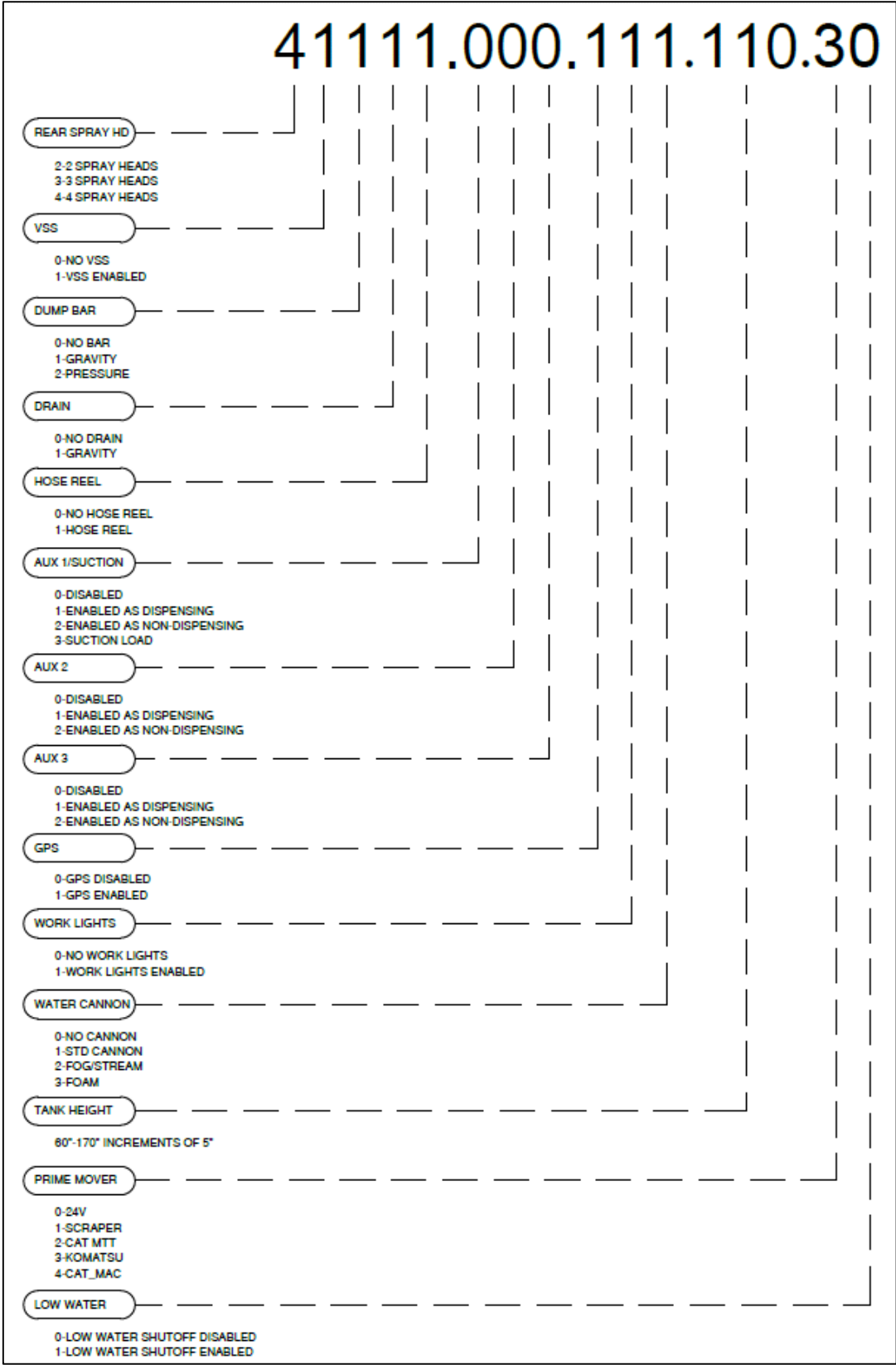

SECTION 3 Cab Control System

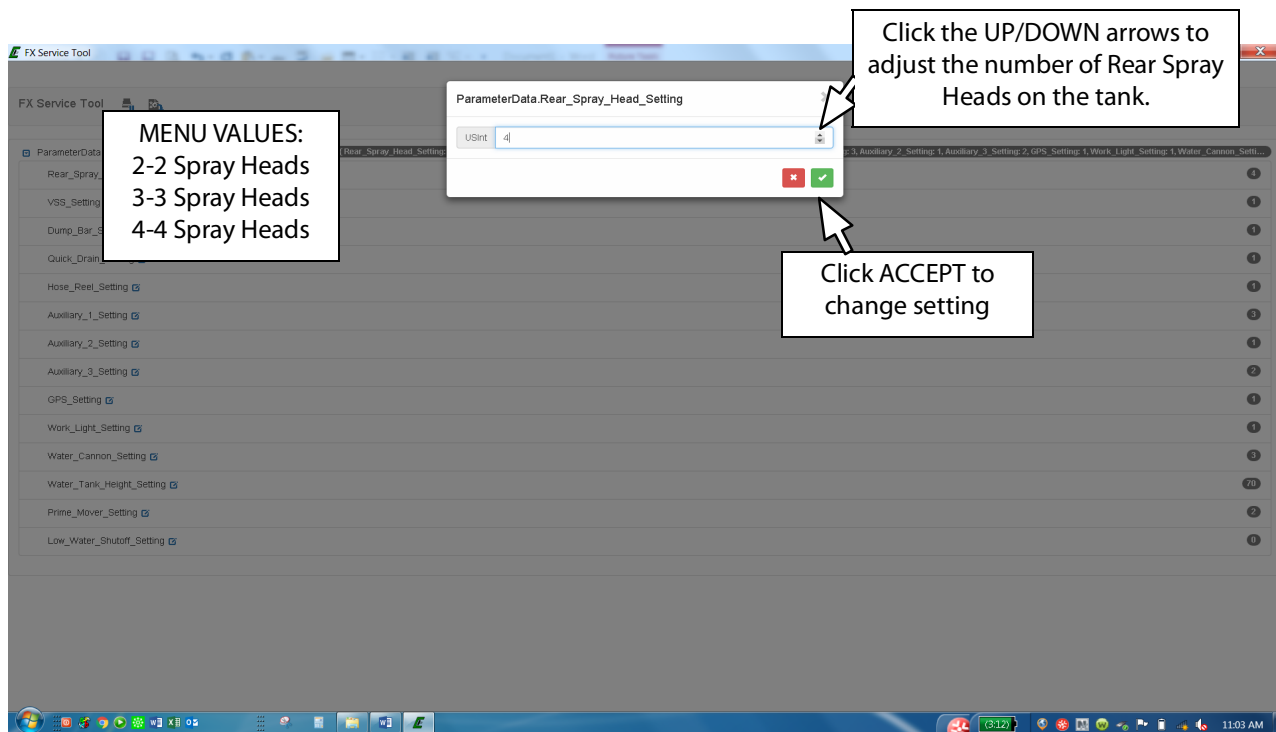
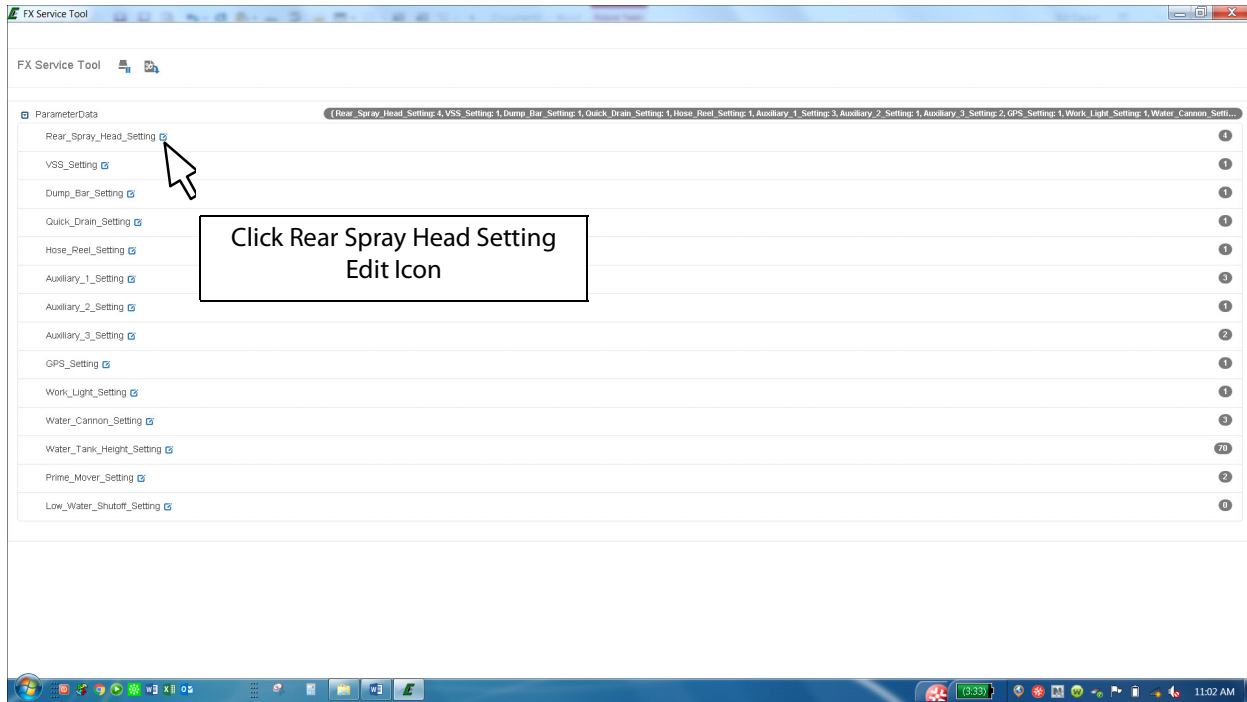

SECTION 3 Cab Control System

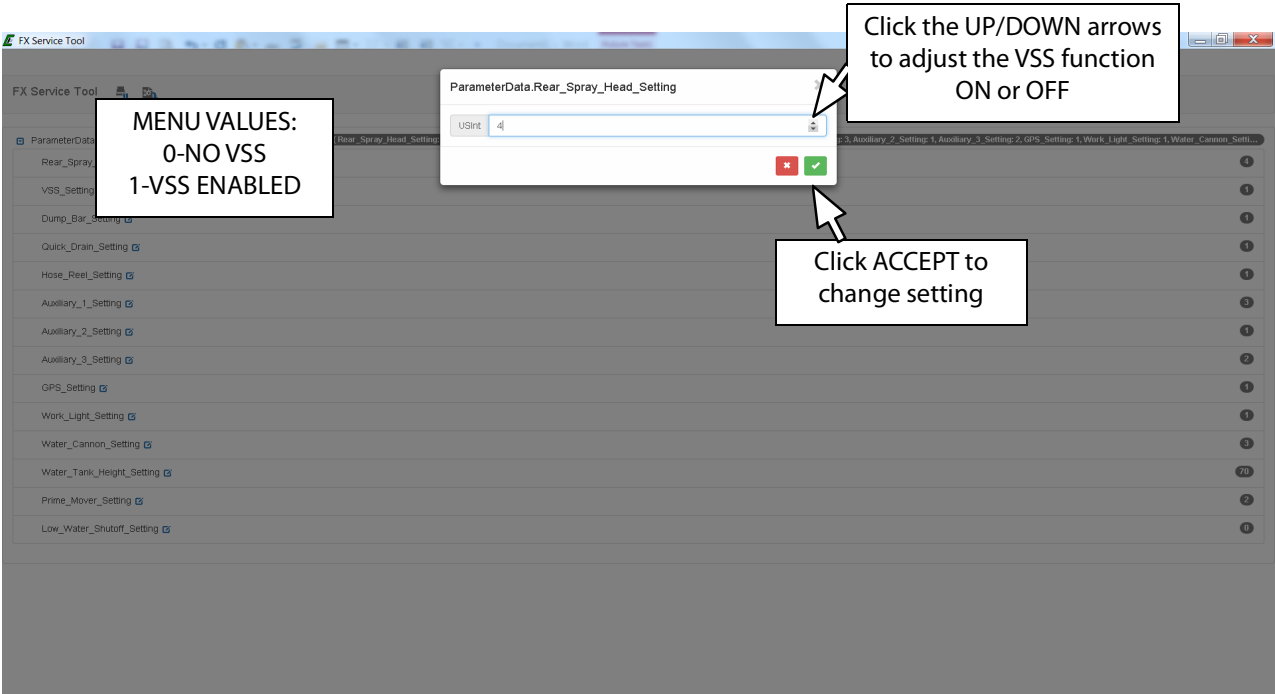
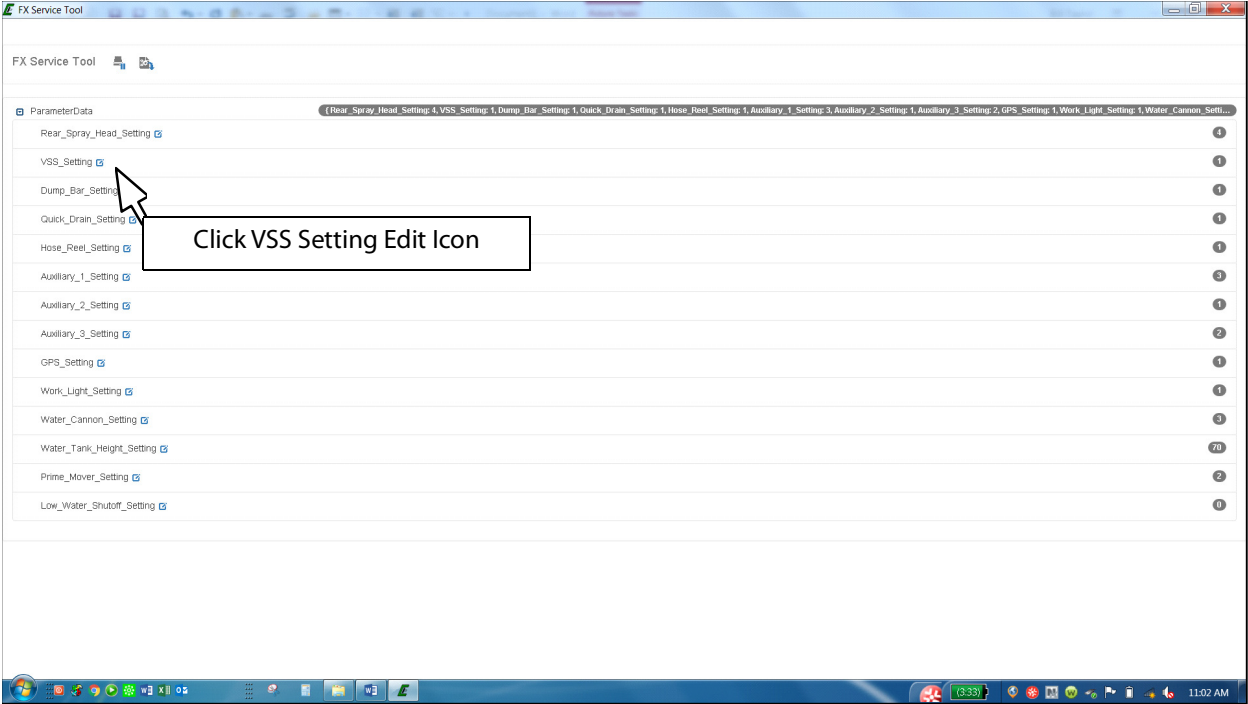

SECTION 3 Cab Control System

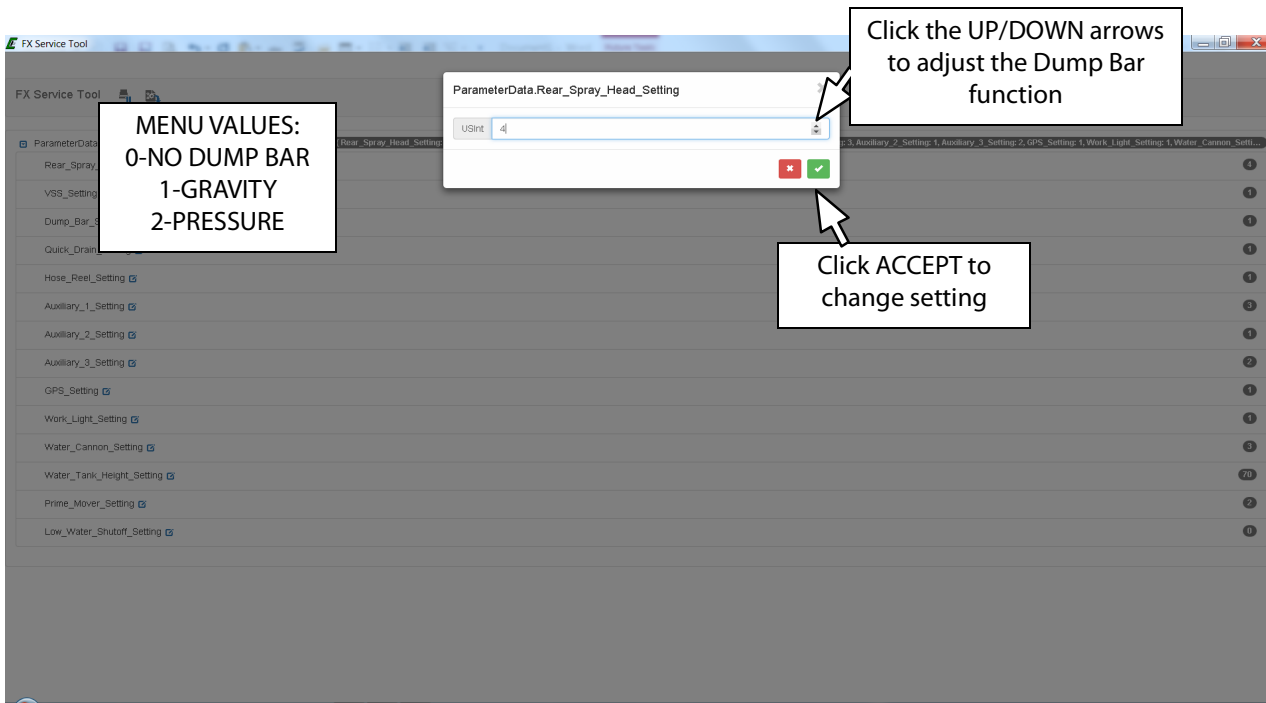
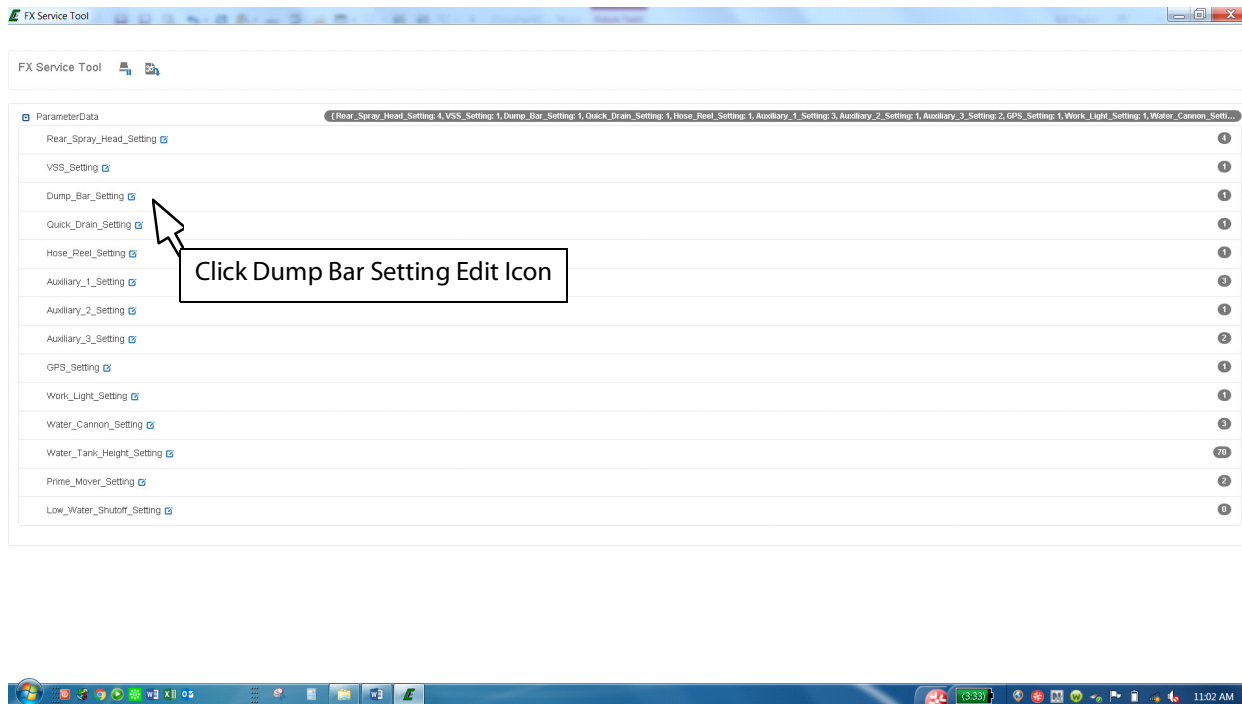

SECTION 3 Cab Control System

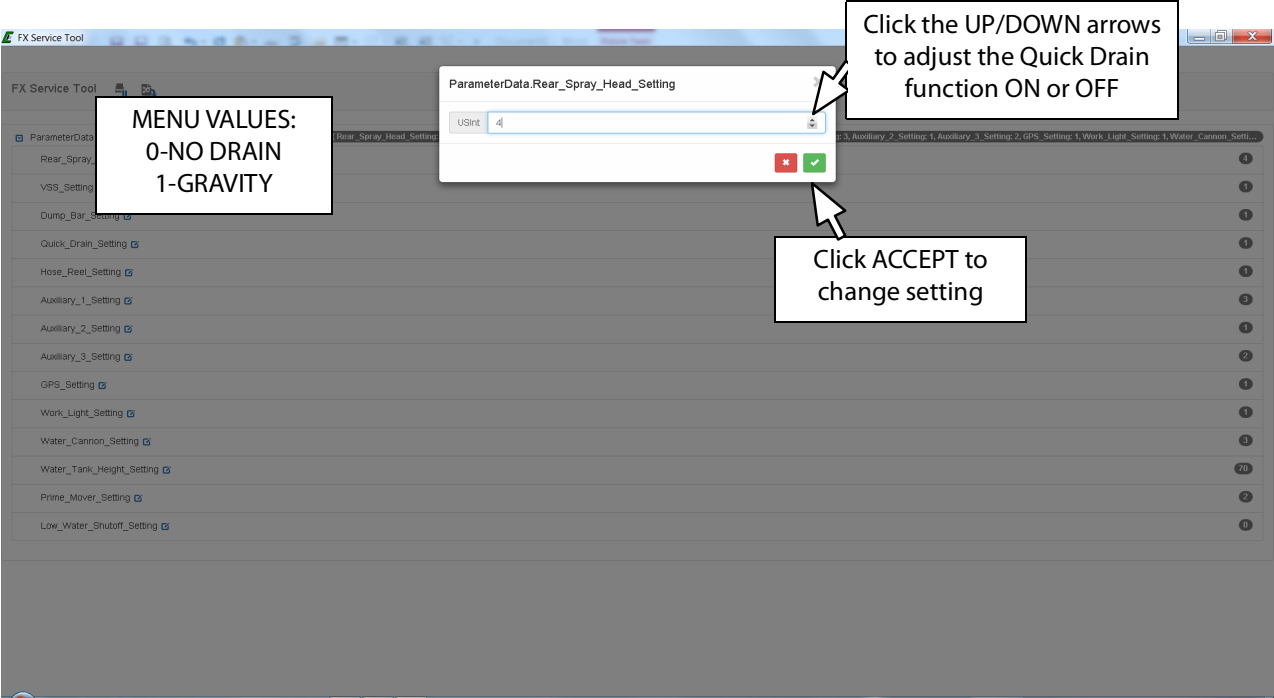
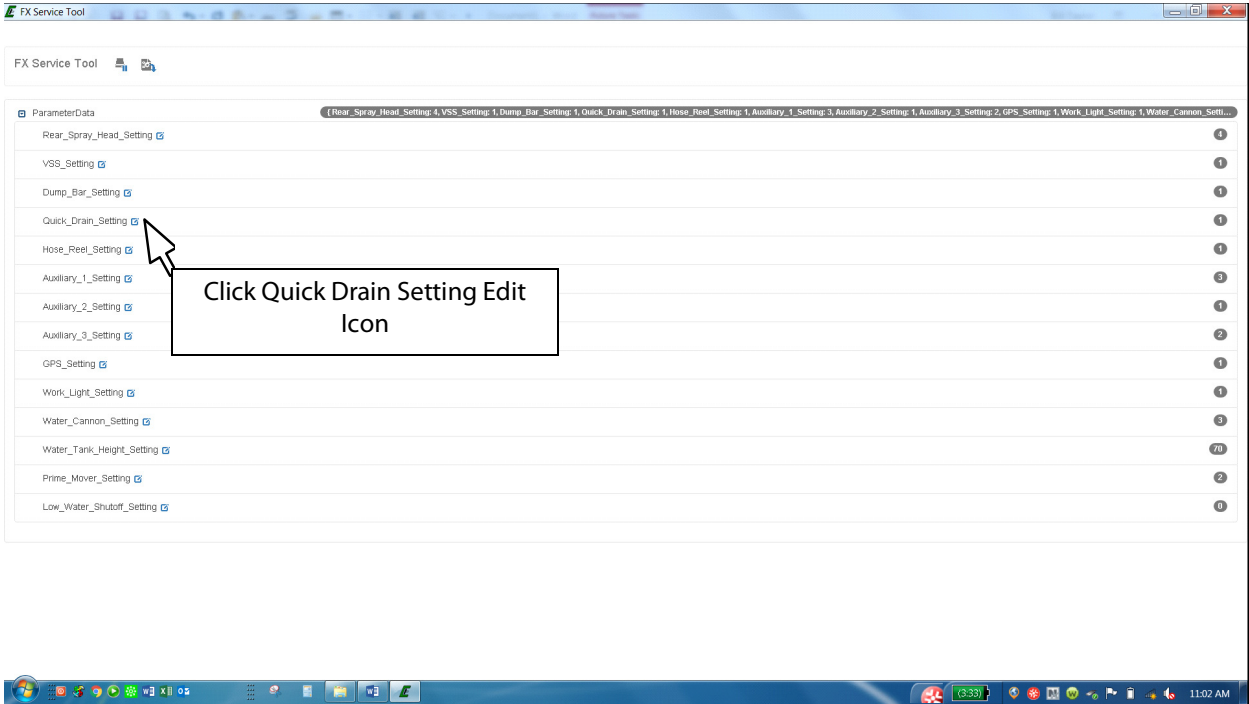

SECTION 3 Cab Control System

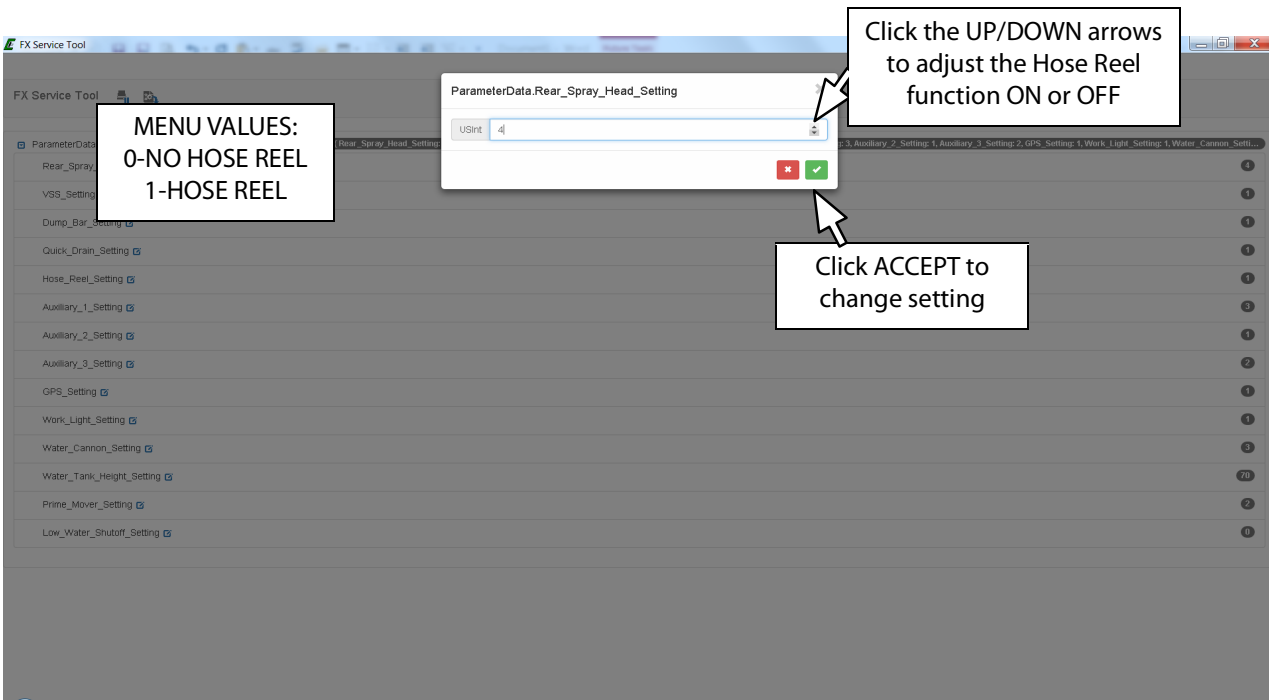
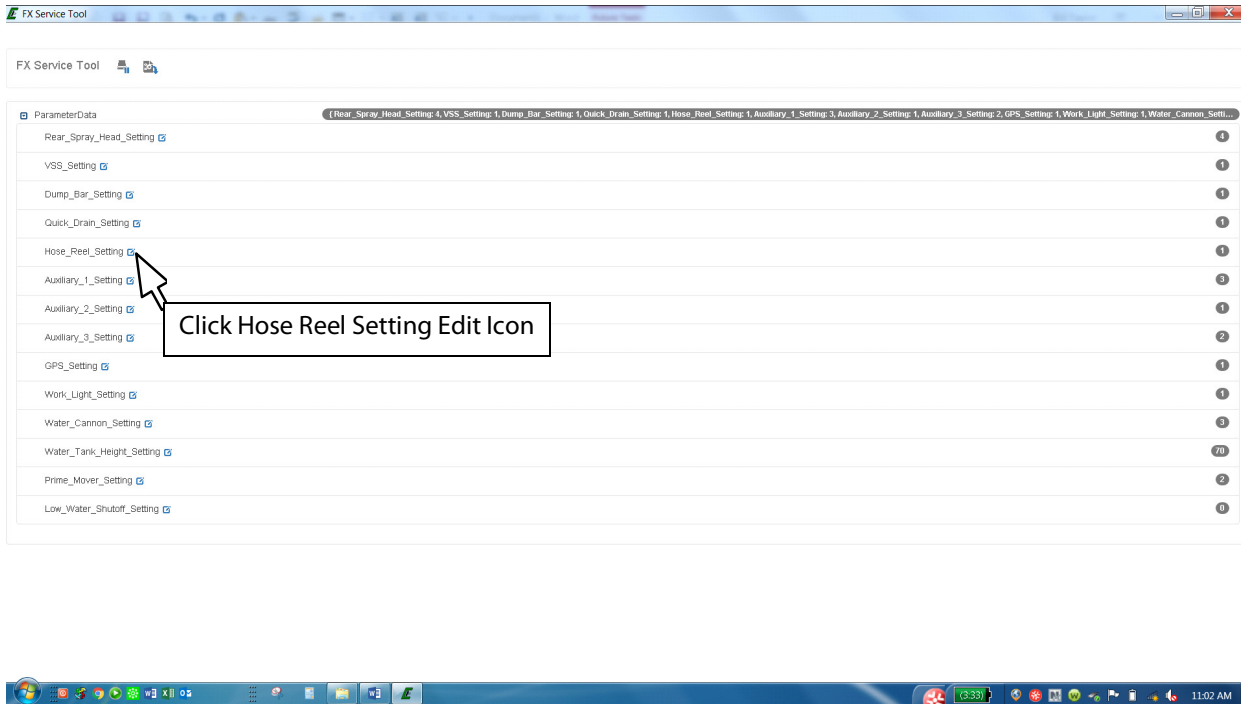

SECTION 3 Cab Control System

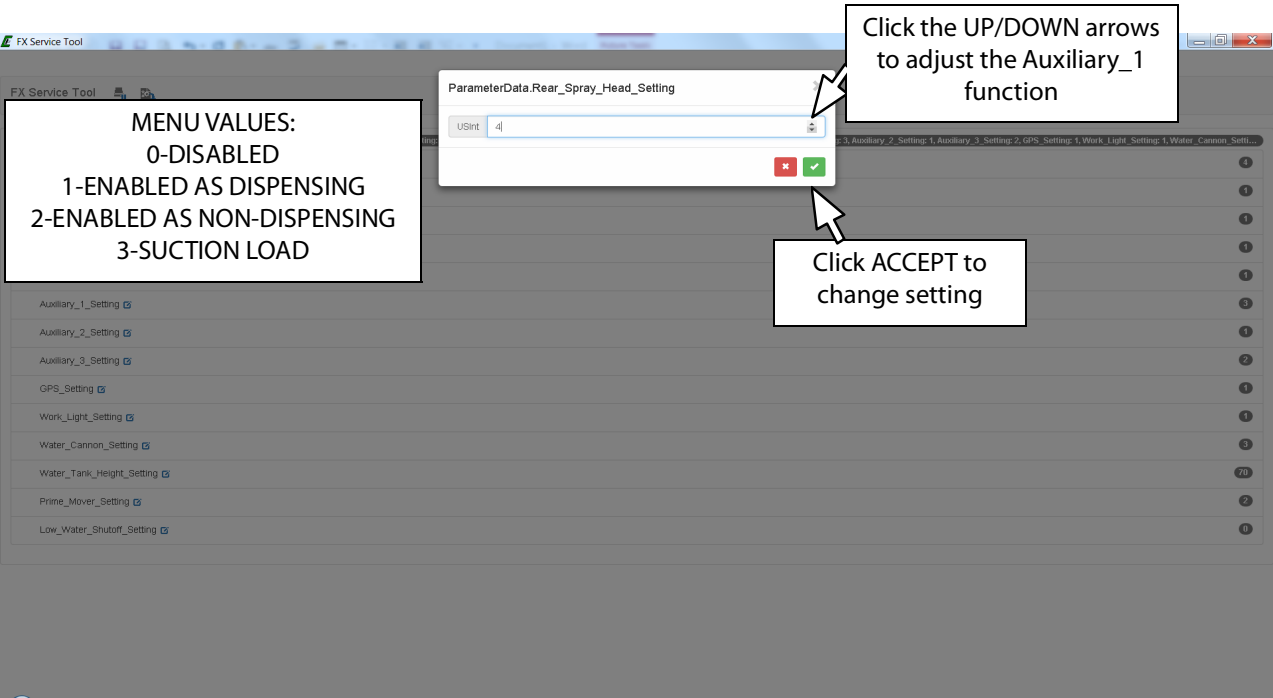
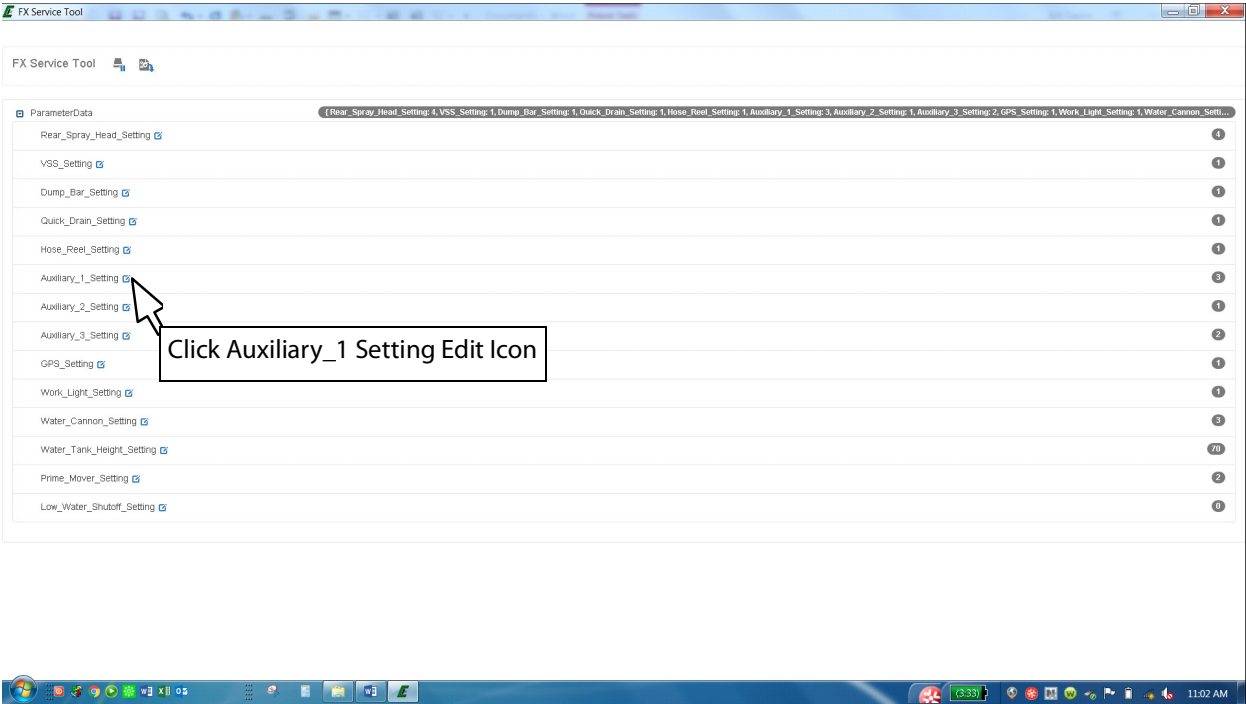

SECTION 3 Cab Control System

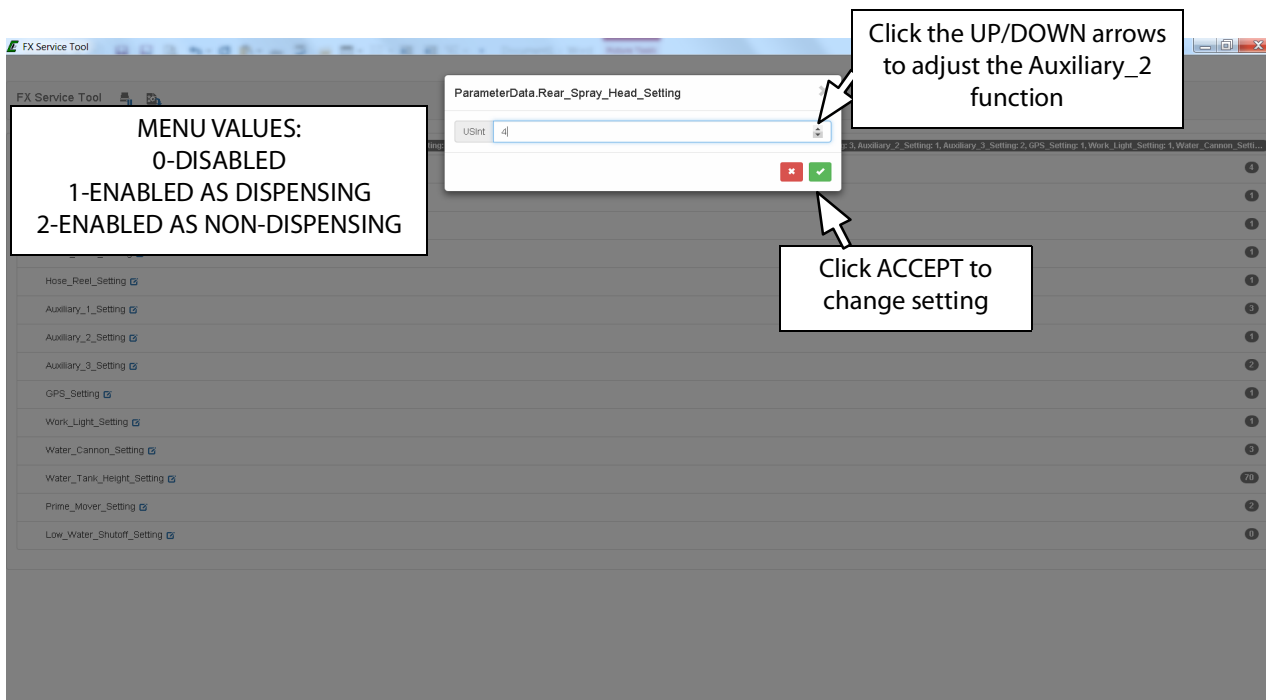
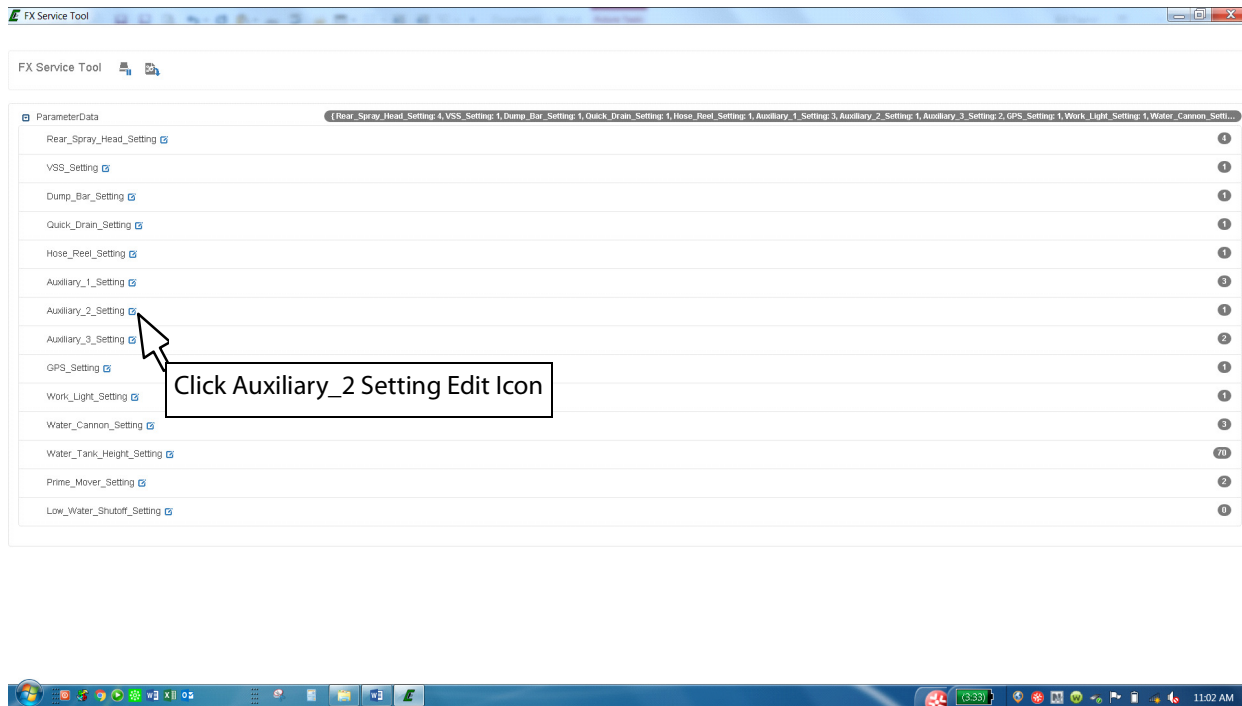

SECTION 3 Cab Control System

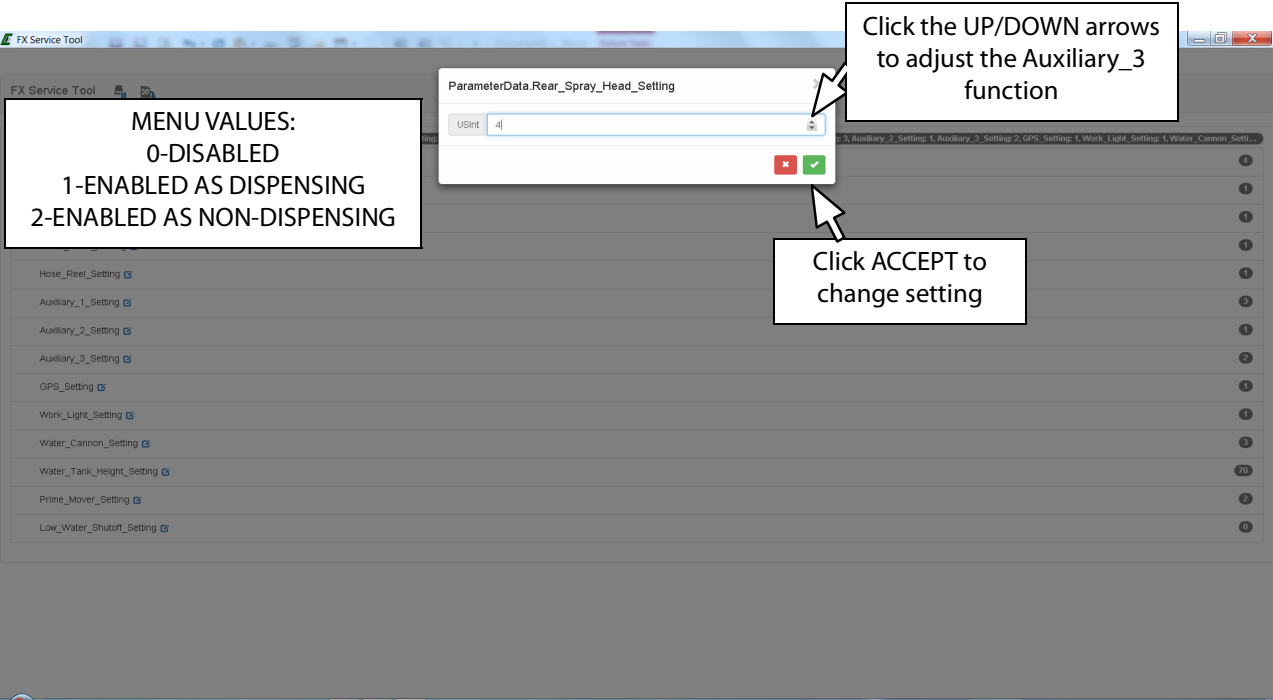
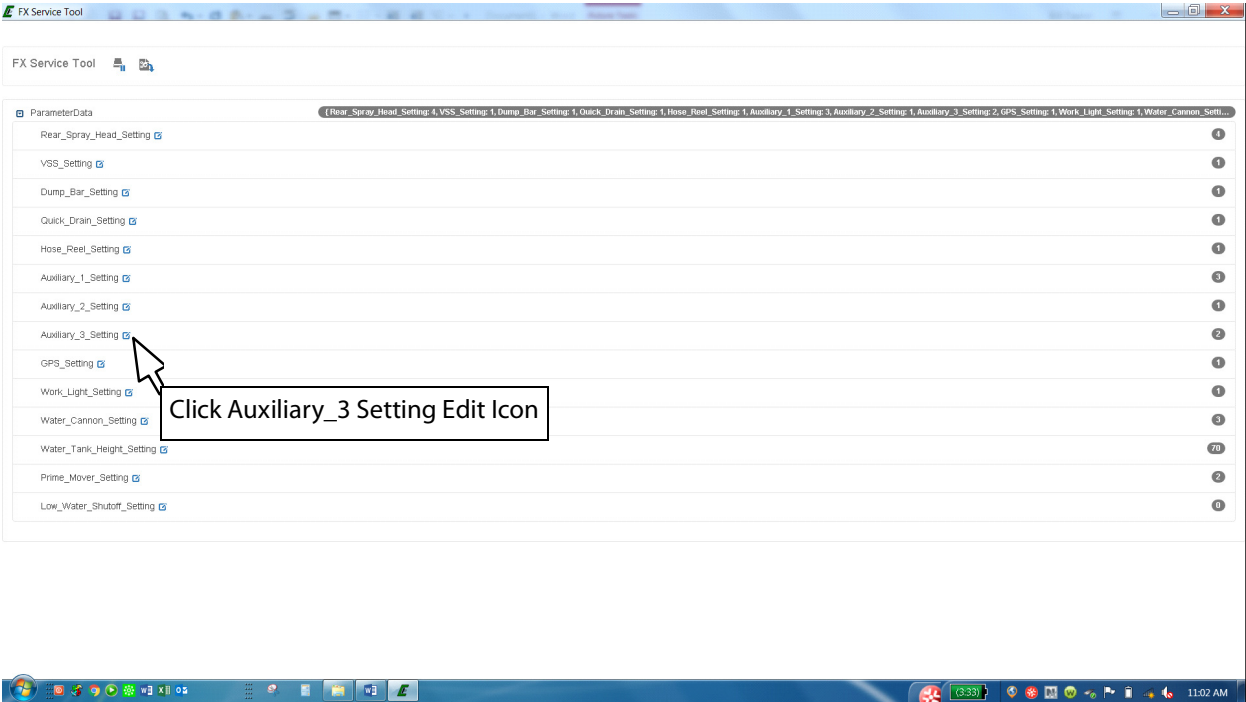

SECTION 3 Cab Control System

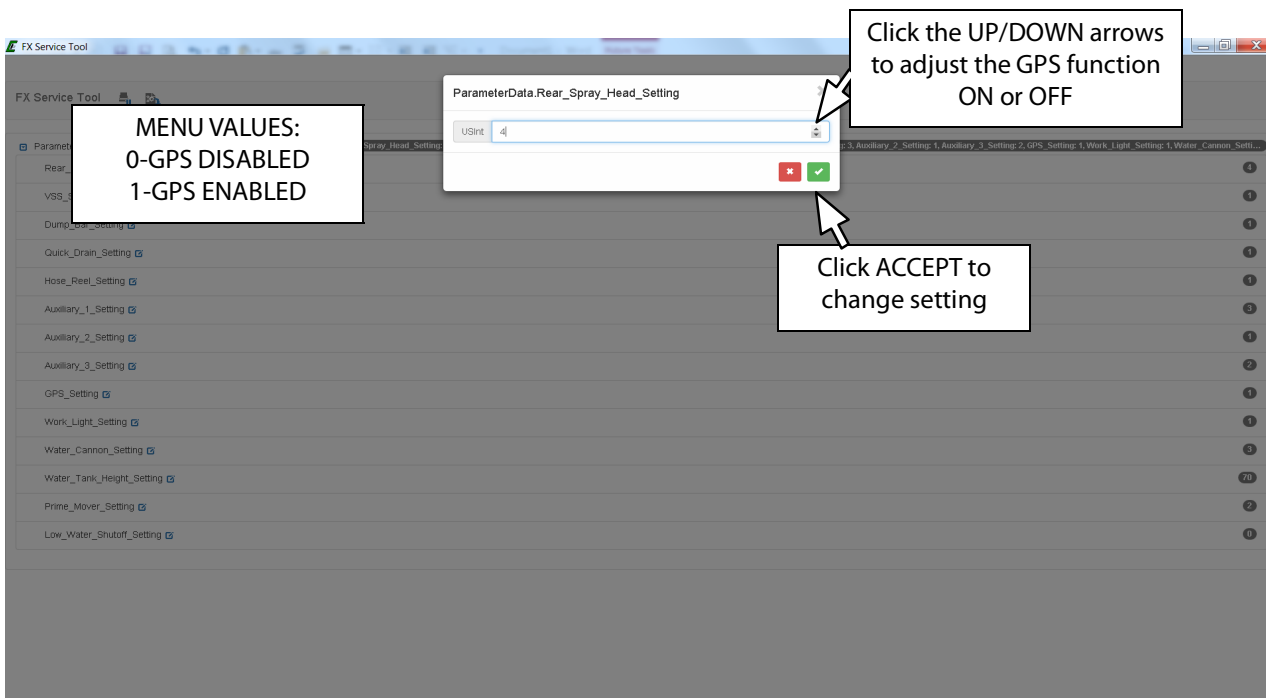
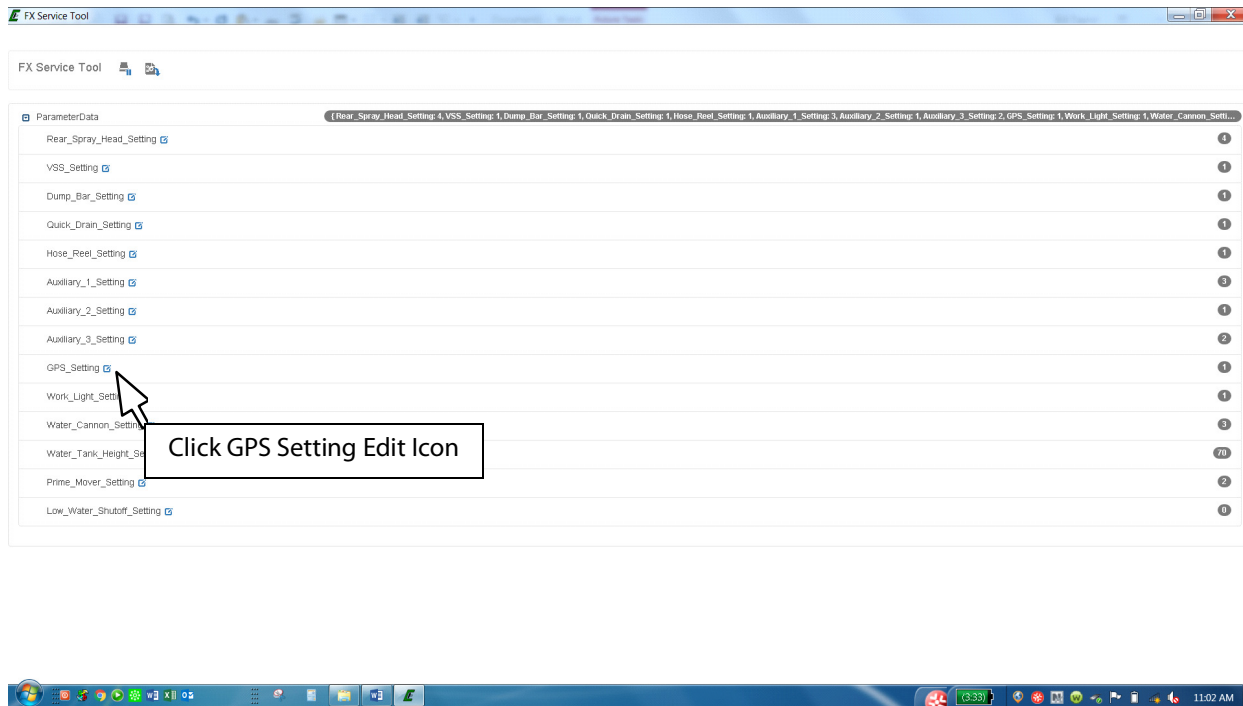

SECTION 3 Cab Control System

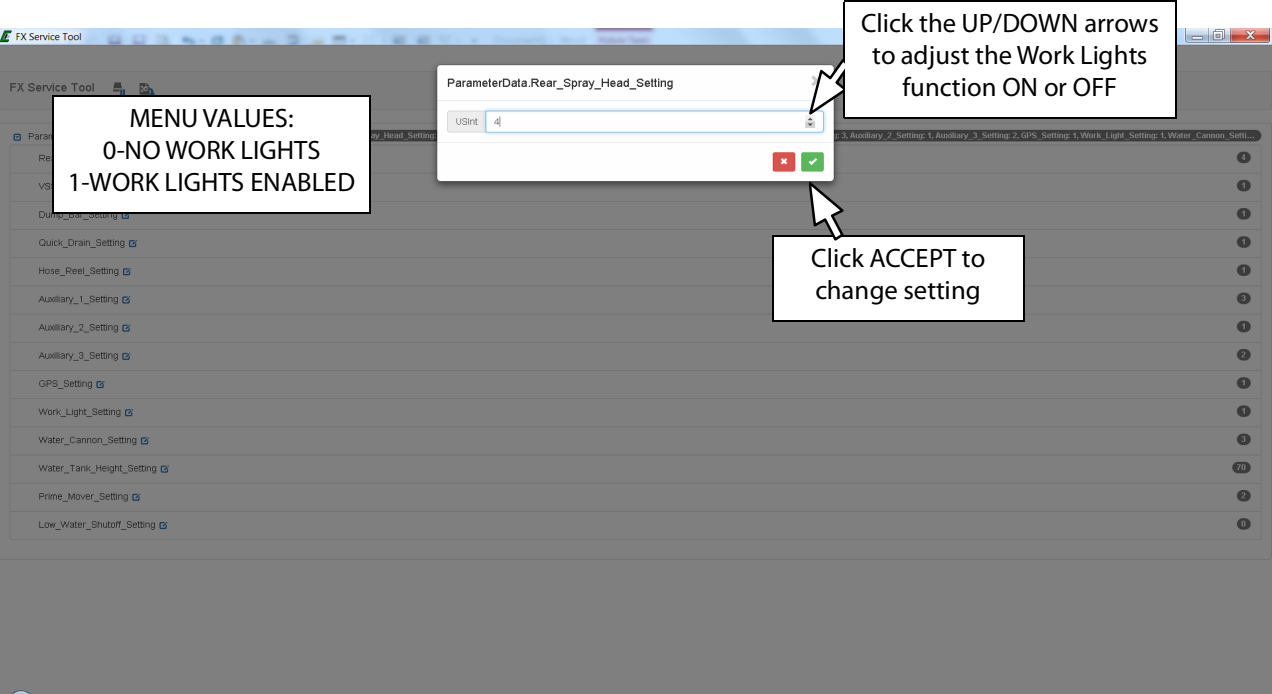
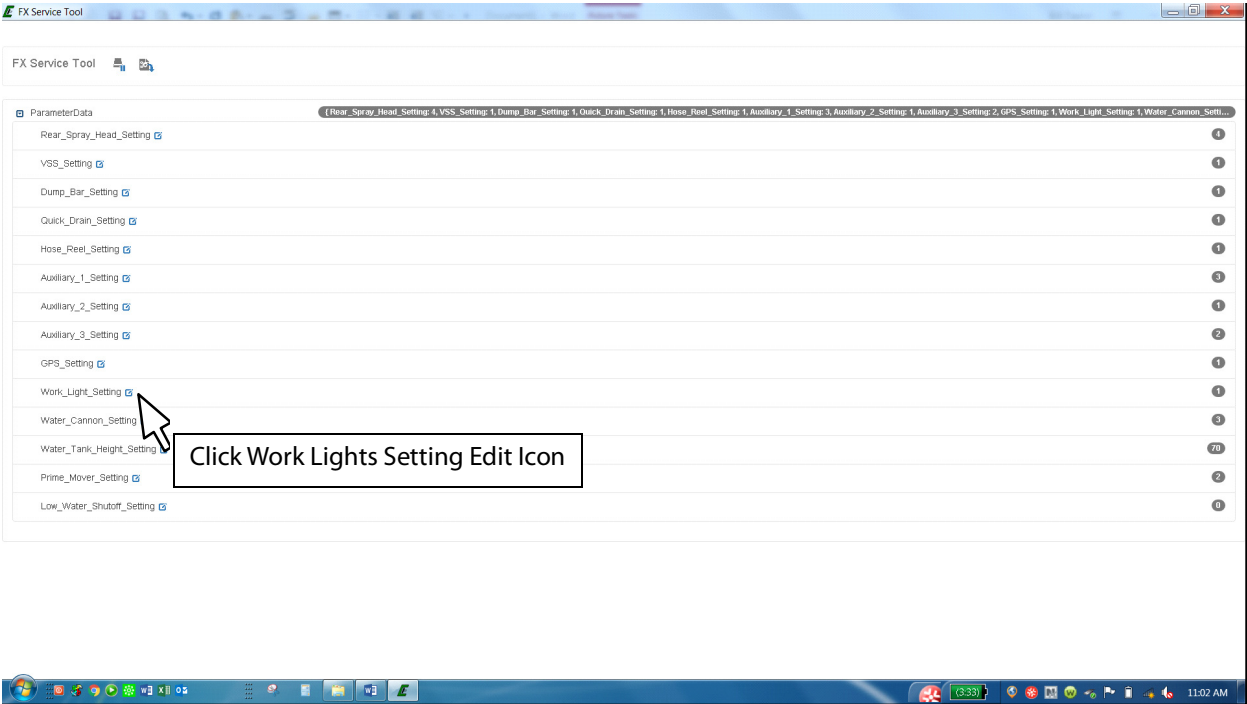

SECTION 3 Cab Control System

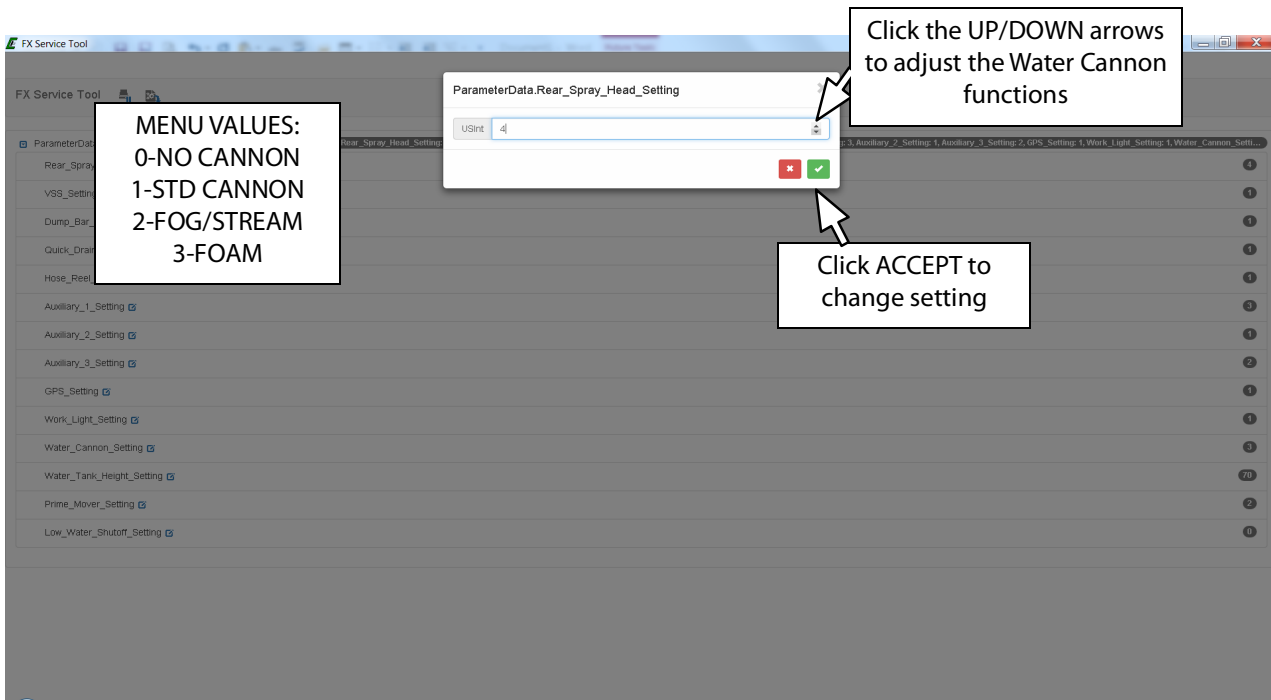
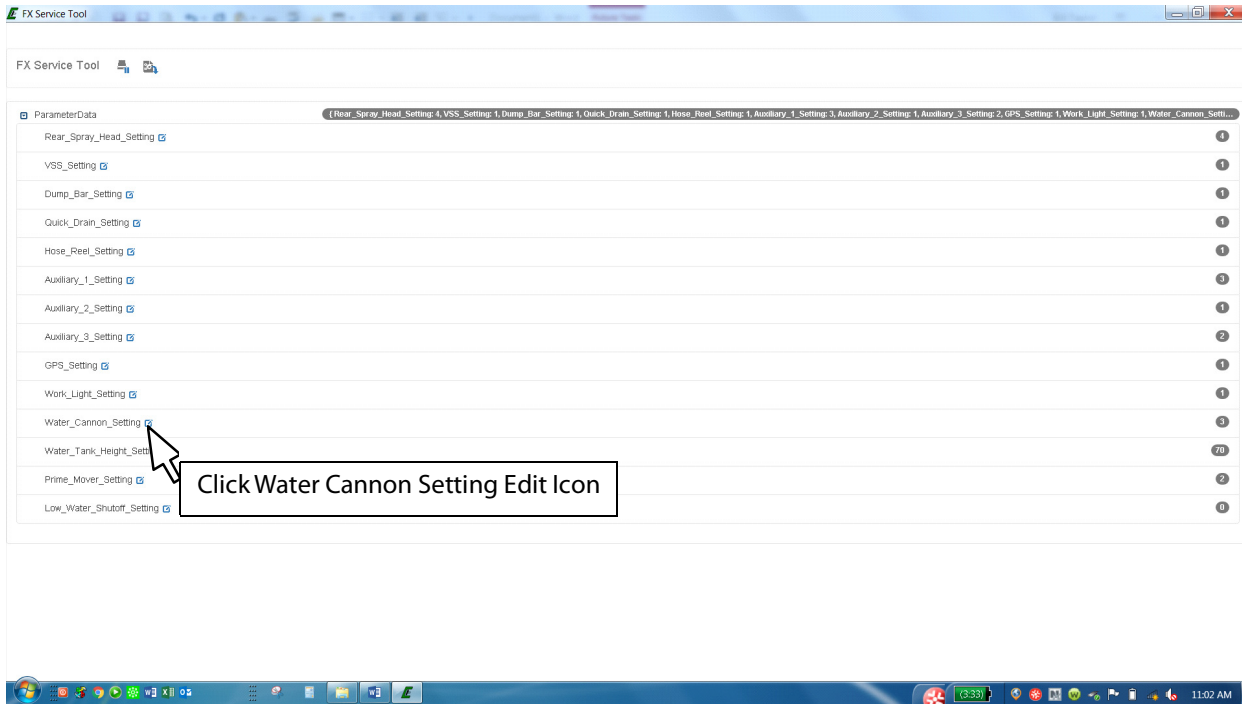

SECTION 3 Cab Control System

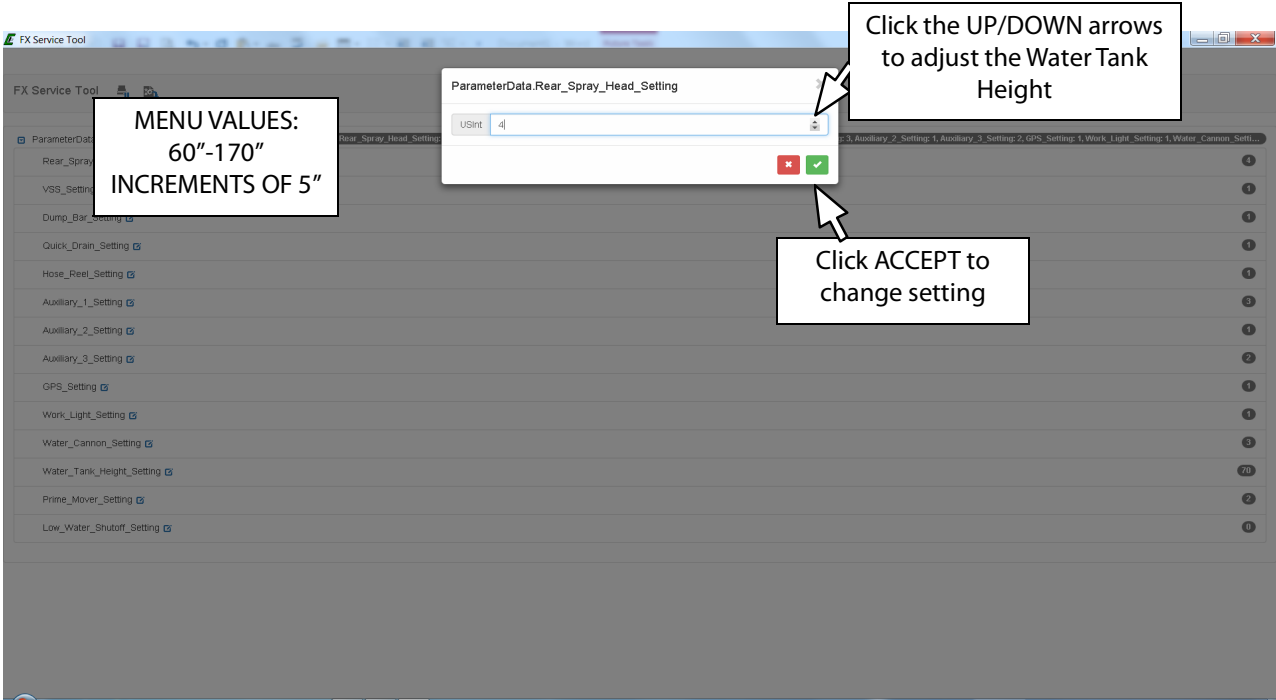
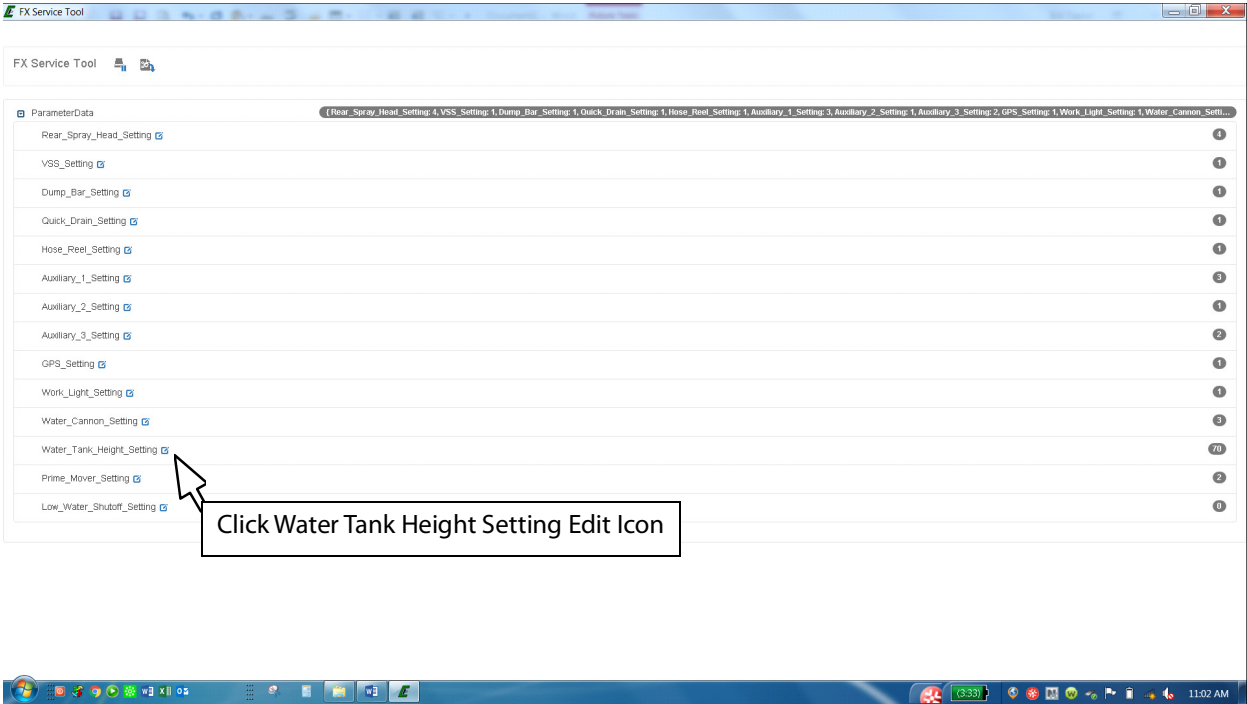

SECTION 3 Cab Control System

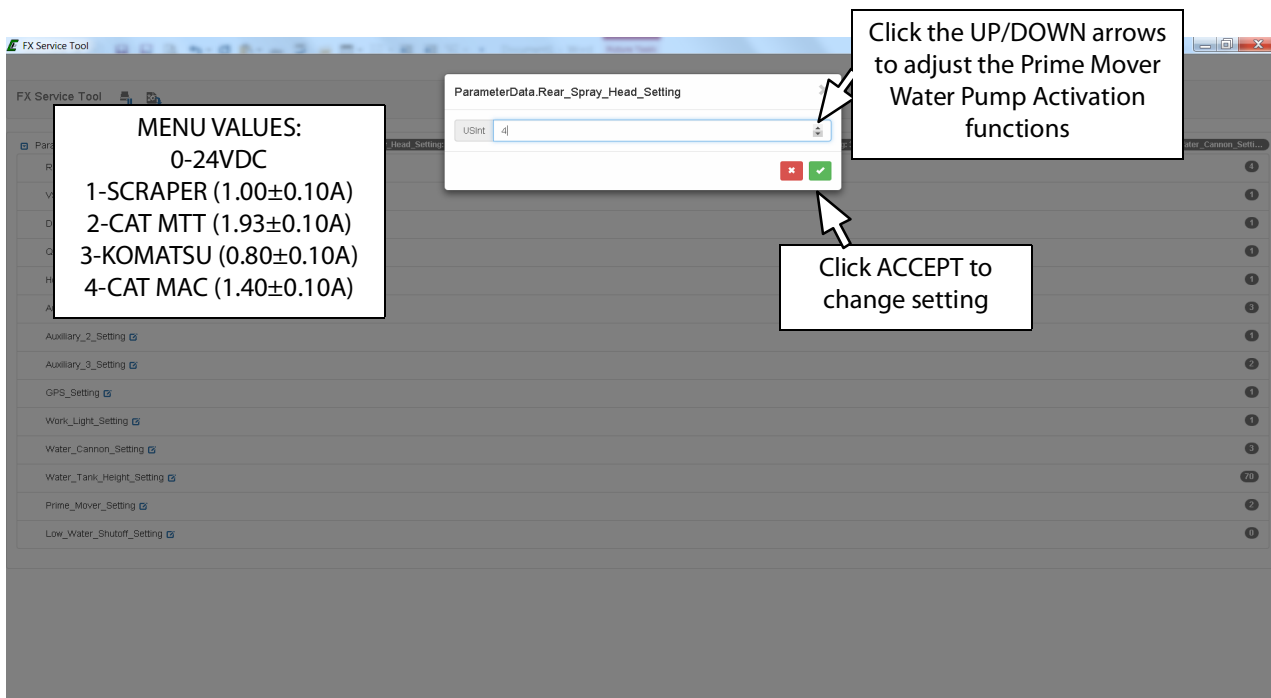
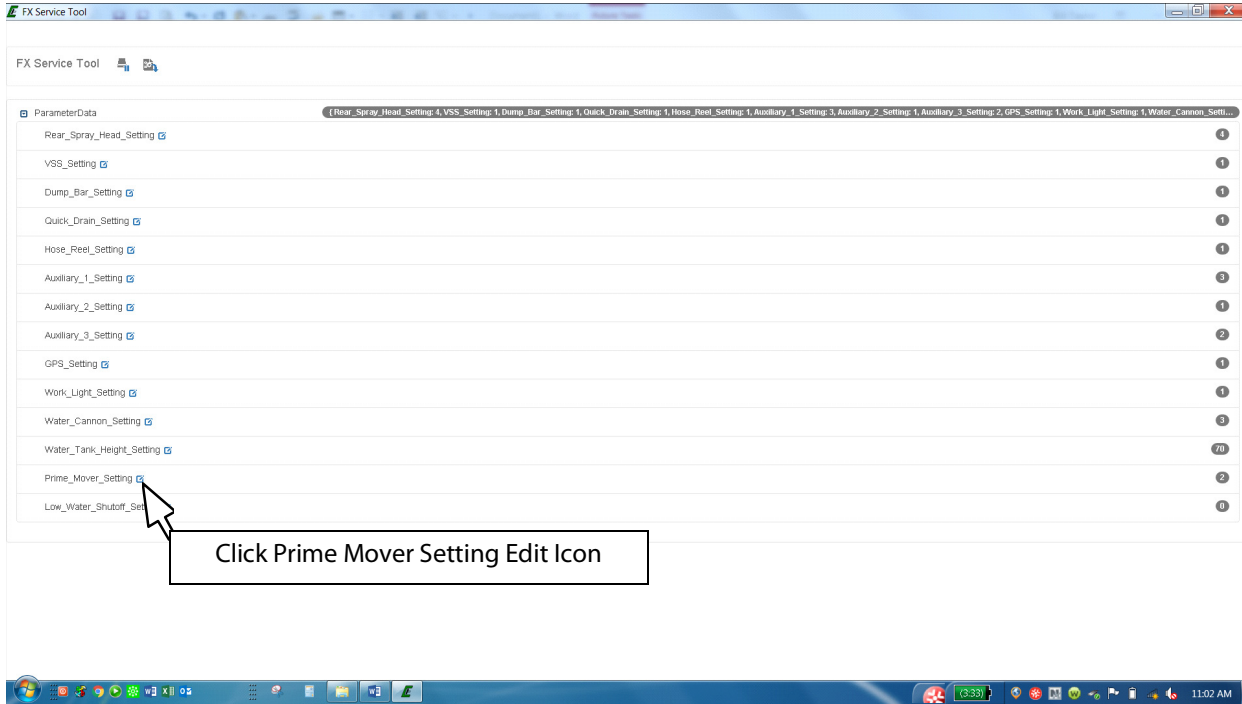

SECTION 3 Cab Control System

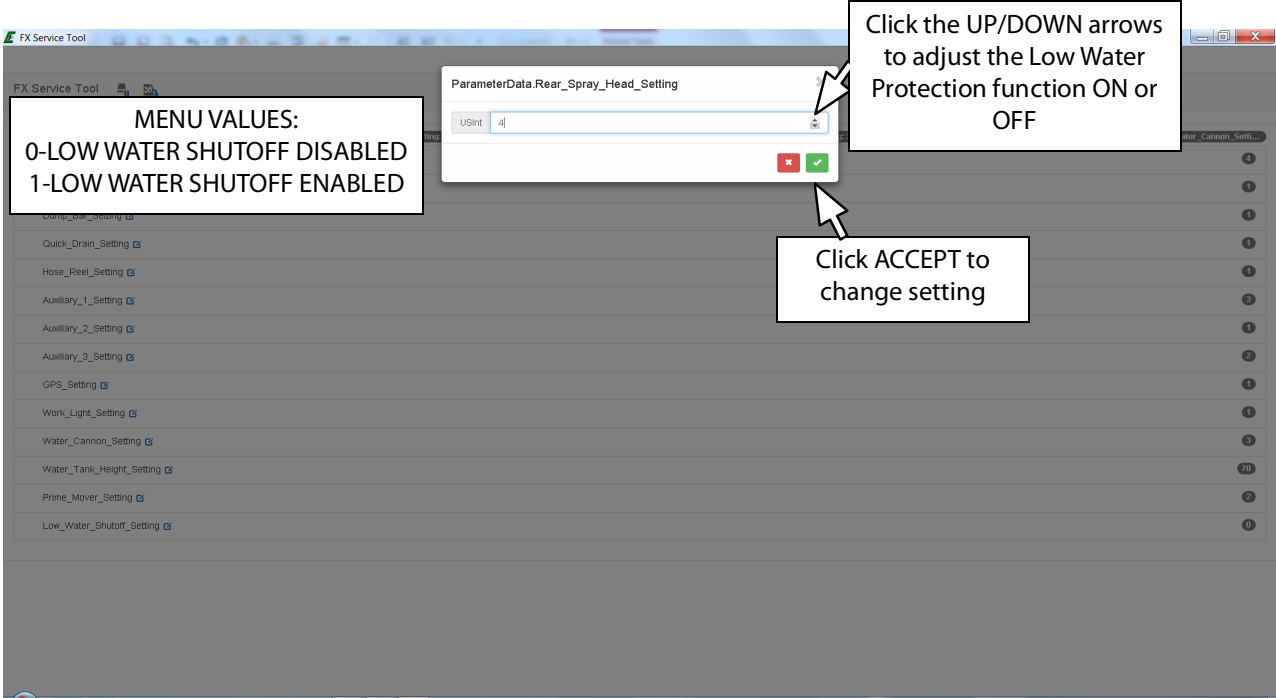
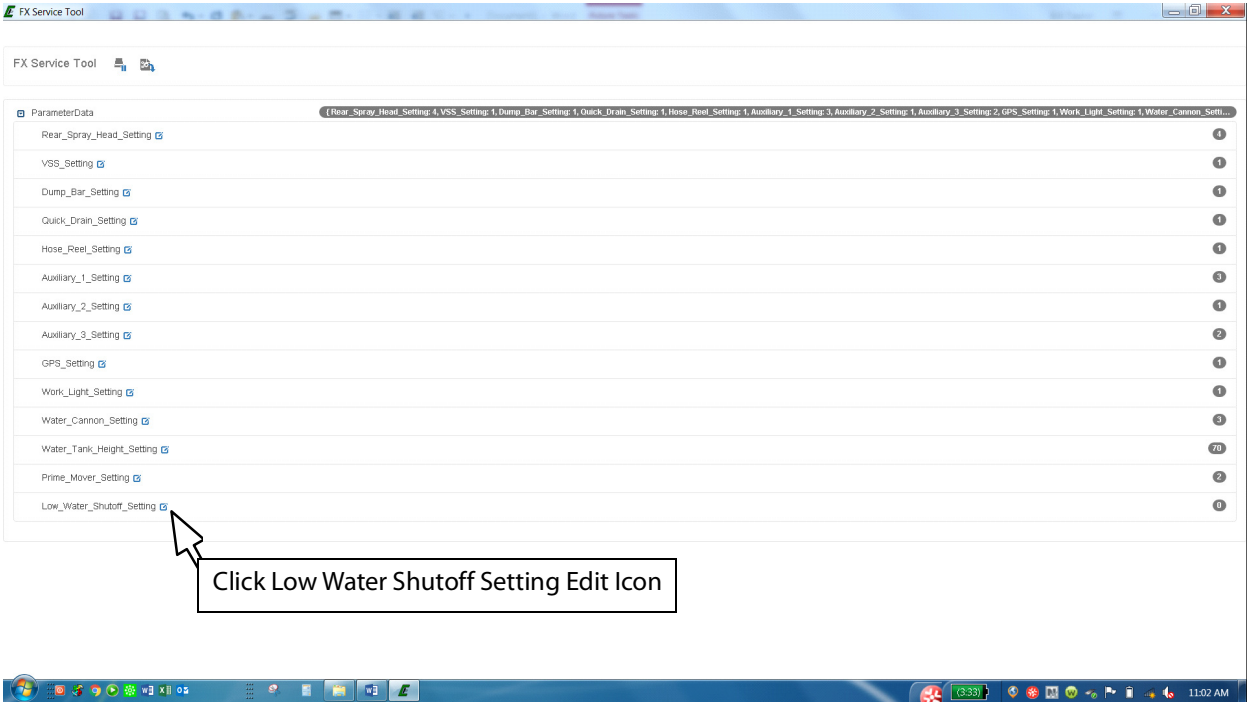

SECTION 3 Cab Control System

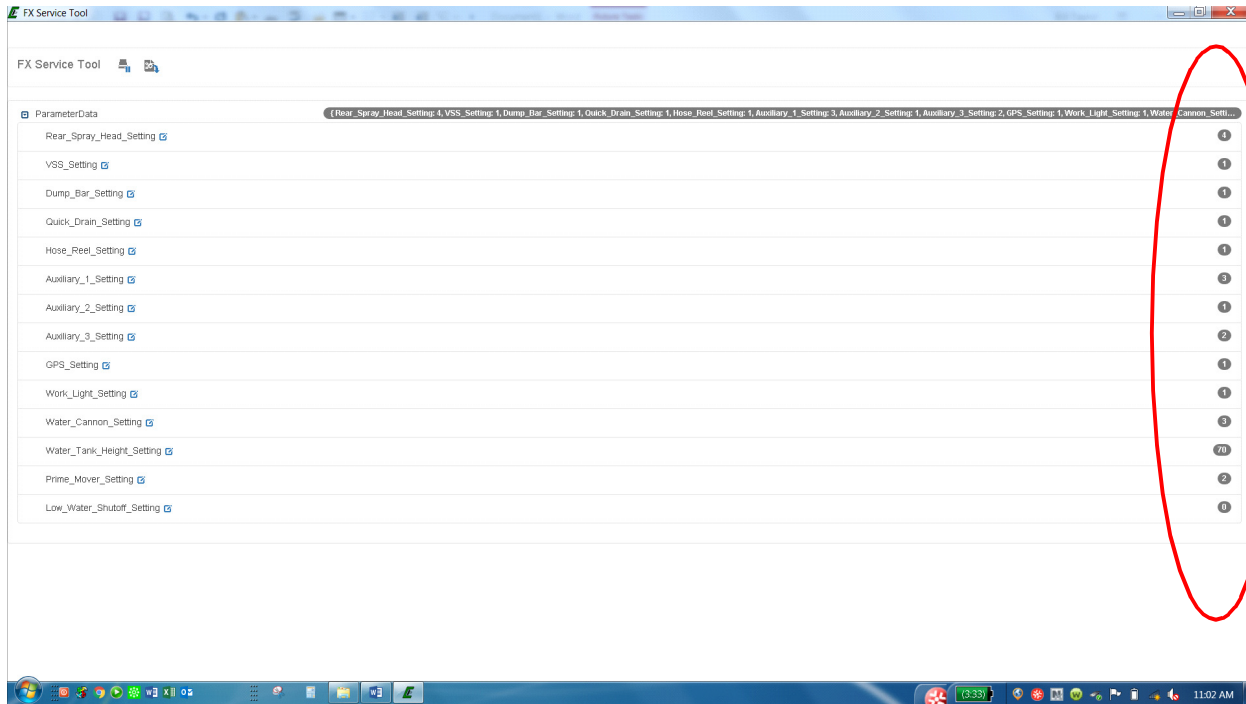

18. When the configuration is complete, ensure that all parameters have been changed to the desired settings.

19. Write and save this configuration line code and file with machine history for future reference.

NOTE

If you are having difficulties with the installation, please contact the MEGA Corp. Product Support Group at:

US Toll Free: 1-800-345-8889

Direct: 1-505-345-2661

Or visit our website at www.megacorpinc.com for more contact information.

SECTION 3 Cab Control System

CONFIGURATION & PROGRAMMING, GEN 1.5

The DiSCS® system allows for customized configuration based upon the specific tank and chassis, and may also require firmware updates. This portion of the manual provides instructions first for configuration of major components based on user-requested options, tank sizes, and prime movers, followed by procedures for controller address configuration, software downloads, and firmware updates.

Reading Configuration Programming Line Code

Every DiSCS® Gen. 1.5 system is given a specific 10 digit line code that determines what options that specific tank has available. Check your specific Mega tank serial number configuration code in tank-specific control drawings contained in the appropriate Field Installation -4 Technical Manual Appendix Drawings.

The following will explain what each digit (or character) in the line code means.

Example line code is: **1KD4C00JB2**

Characters 1-5

The first five characters in the 10-digit line code determine the type of switches installed on the Master Switch Box and Joystick Box. Each character refers to a set of Bill of Materials item numbers:

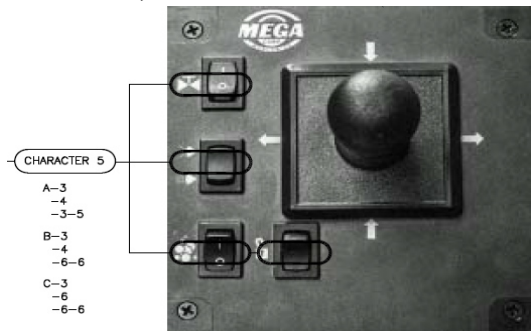

Character 1 (1): Master Switch Box TOP row of switches (POWER, PUMP, INTMNT, and LIGHTS switches are all installed):

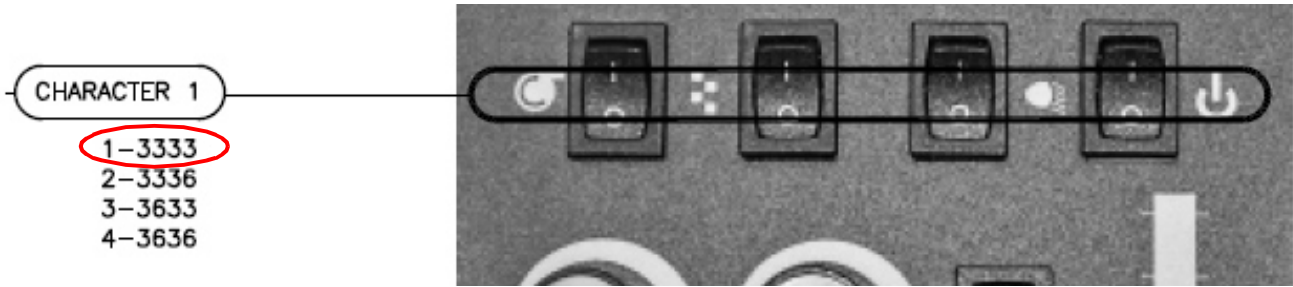

Character 2 (K): Master Switch Box SECOND row from top of switches (AUTO, AUX1, AND AUX2 switches are removed with covers installed, and the HOSE switch is installed):

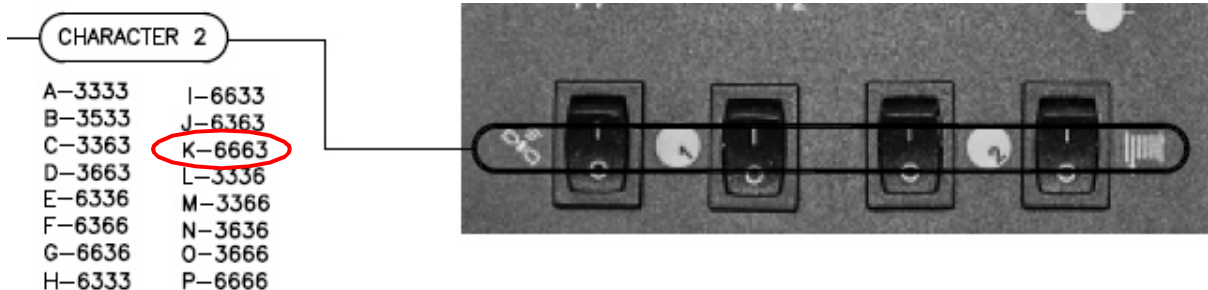

SECTION 3 Cab Control System

Character 3 (D): Master Switch Box THIRD row from top of switches (LT VSS and RT VSS are *installed*; DRAIN and DUMP BAR switches are *removed* with covers installed):

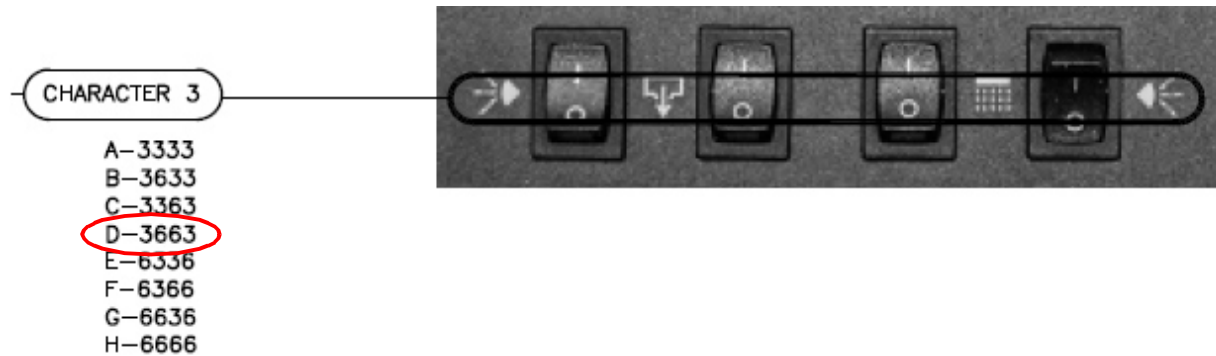

Character 4 (4): Master Switch Box BOTTOM row of switches (LTR, LTC, RTC, RTR switches are *installed*):

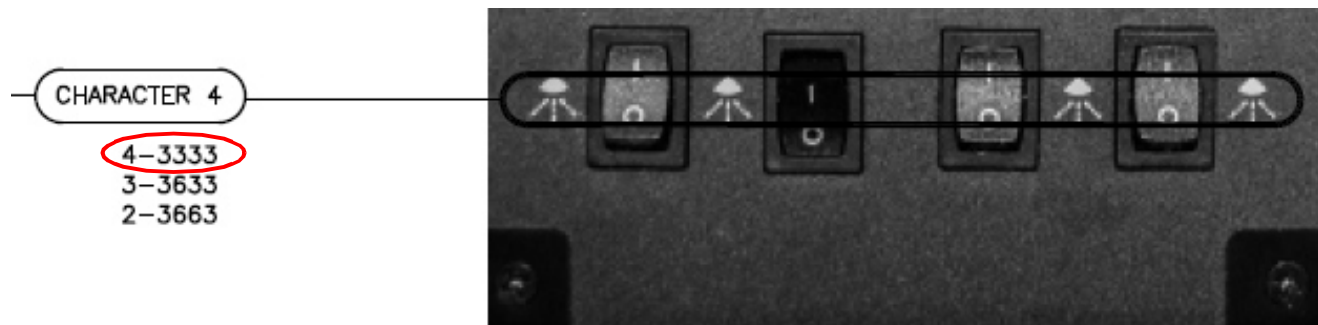

Character 5 (C): Joystick Box switch configuration (FOAM and NOZZLE switches are *removed* with covers installed; BFV switch is *installed*):

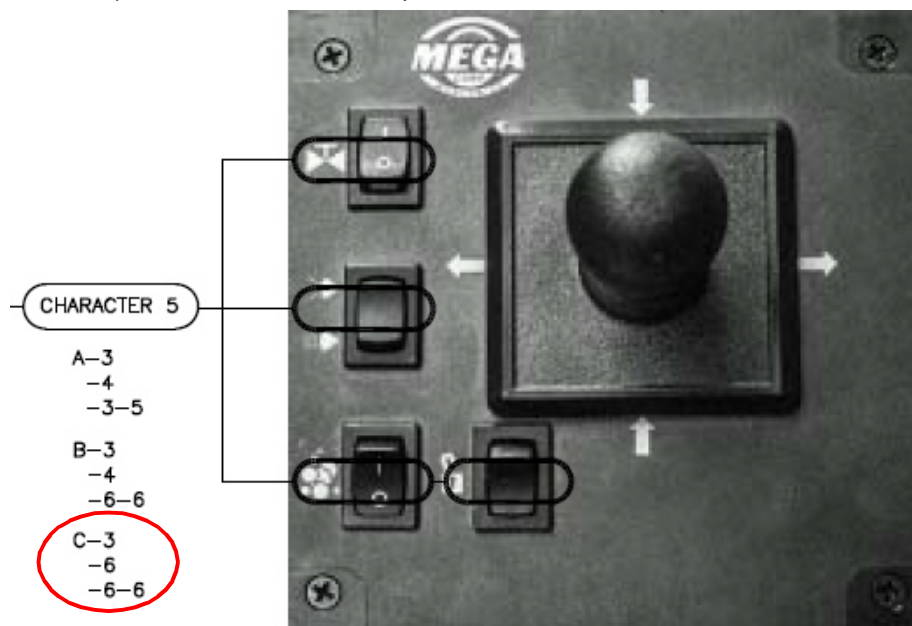

SECTION 3 Cab Control System

Tank Configuration Switches & Water Level Dip Switches (Characters 6-10)

Characters 6-10 correspond to DIP switches located on the Switch Box Board and Master Board. Refer to the figure below for the locations of these DIP switches.

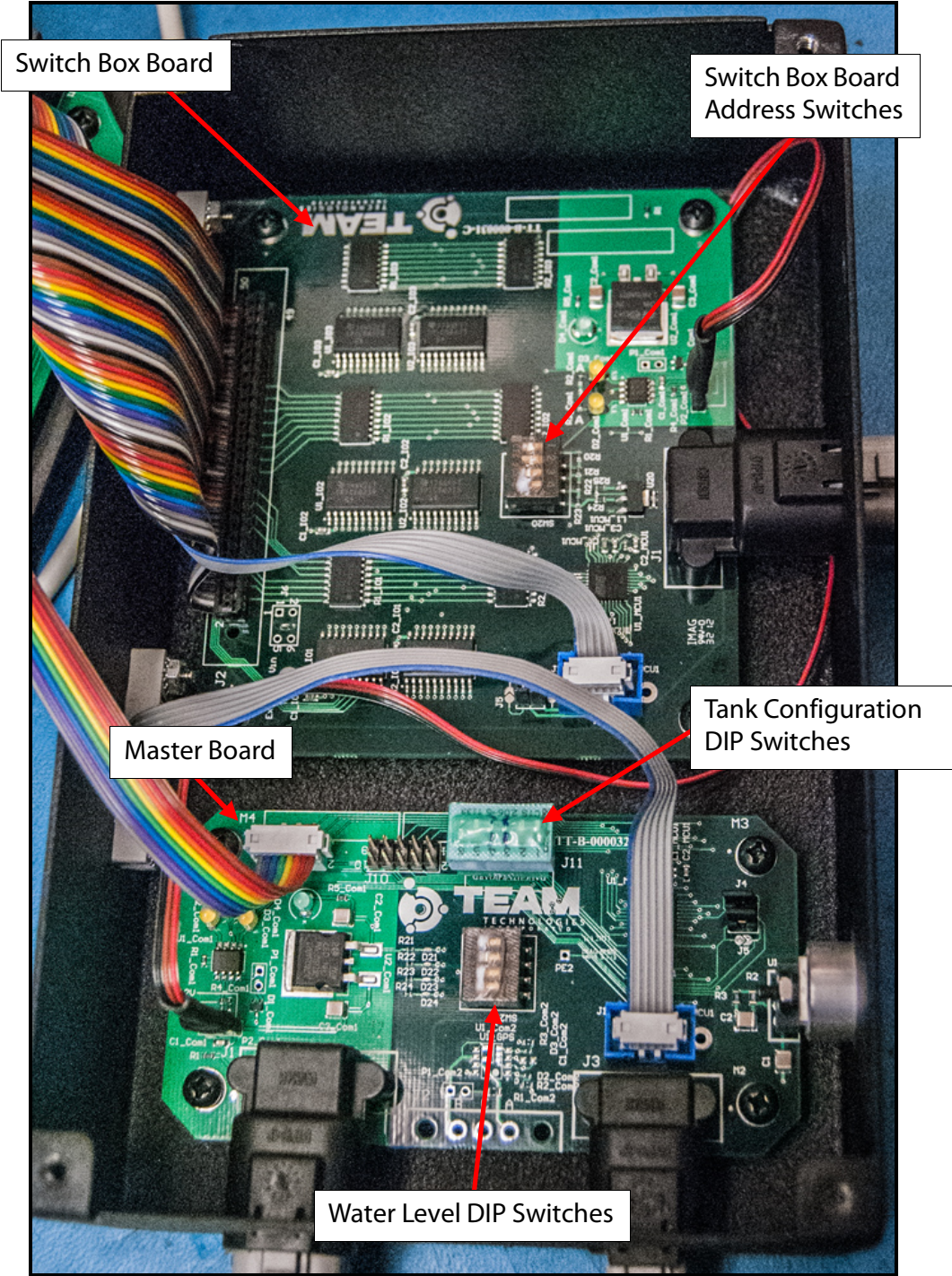

SECTION 3 Cab Control System

Character 6 (0): This Character is for the Master Board Tank Configuration DIP Switches for switch #2 (Dump Bar switch). If the unit does not have this option, the switch position will default to OFF. This unit either does not have a Dump Bar option or it has a Gravity Dump Bar, so this switch remains OFF.

- CHARACTER 6
- (DUMP BAR DIP SWITCH, SW2)
- 1—SW2 ON, PRESSURE
- 0—SW2 OFF, GRAVITY

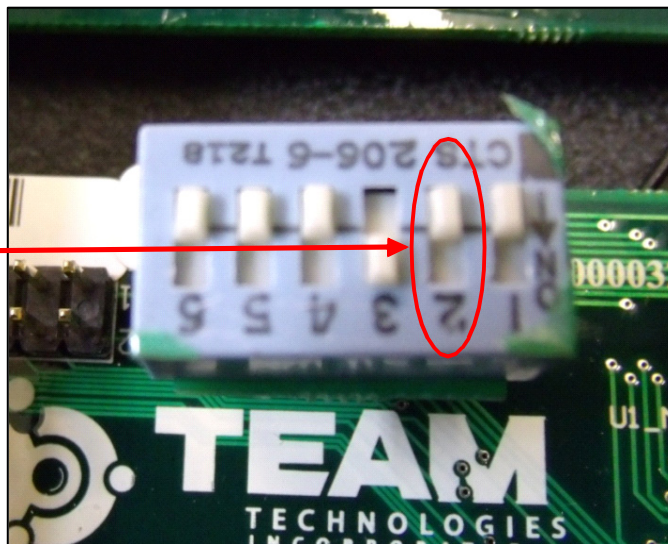

Character 7 (0): This Character is for the Master Board Tank Configuration DIP Switches for switch #1 (Drain switch). If the unit does not have this option, the switch position will default to OFF. This unit does not have a Drain option, so this switch remains OFF.

- CHARACTER 7
- (REMOTE DRAIN DIP SWITCH, SW1)
- 1—SW1 ON, PRESSURE
- 0—SW1 OFF, GRAVITY

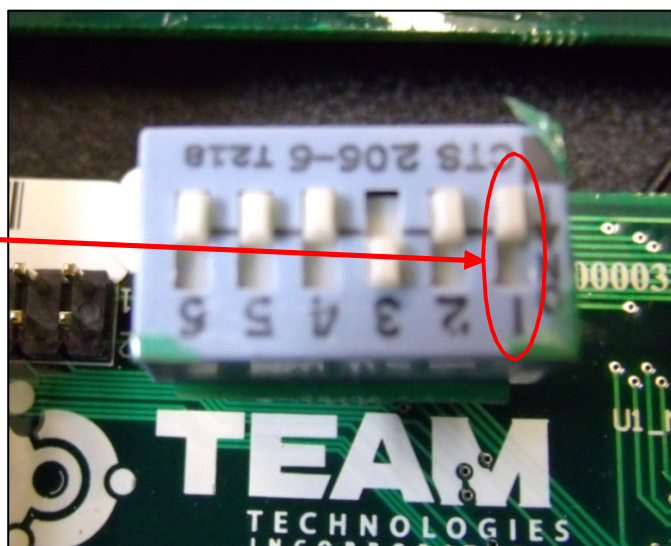

SECTION 3 Cab Control System

Character 8 (J): This Character is for the WATER LEVEL CALIBRATION located on the Master Board Water Level DIP Switches, and is set to the specific height of the tank. This example tank is 90" tall. (1 refers to ON, 0 refers to OFF). If water level setting is incorrect for the tank height, the low water protection feature may not operate at the designed level causing an excess amount of water to remain in the tank.

CHARACTER 8

(WATER LEVEL SENSOR DIP SWITCHES, (1-4) 1=ON 0=OFF

- A-SWITCHES SET TO 1111 (170")
- B-SWITCHES SET TO 0111 (160")
- C-SWITCHES SET TO 1011 (150")
- D-SWITCHES SET TO 0011 (140")
- E-SWITCHES SET TO 1101 (130")
- F-SWITCHES SET TO 0101 (120")
- G-SWITCHES SET TO 1001 (110")
- H-SWITCHES SET TO 0001 (100")
- I-SWITCHES SET TO 1110 (95")
- J-SWITCHES SET TO 0110 (90")**
- K-SWITCHES SET TO 1010 (85")
- L-SWITCHES SET TO 0010 (80")
- M-SWITCHES SET TO 1100 (75")
- N-SWITCHES SET TO 0100 (70")
- O-SWITCHES SET TO 1000 (65")
- P-SWITCHES SET TO 0000 (60")

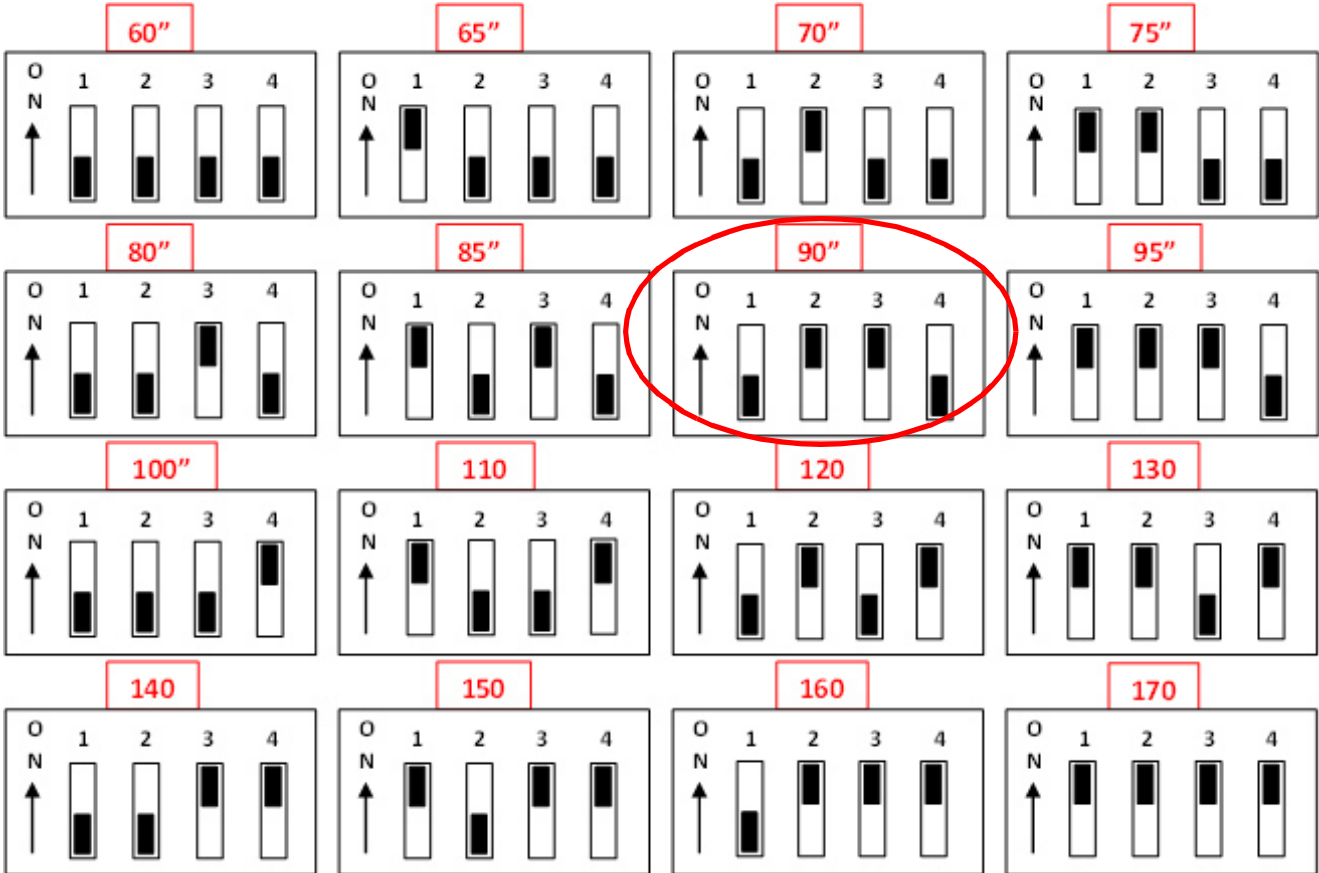
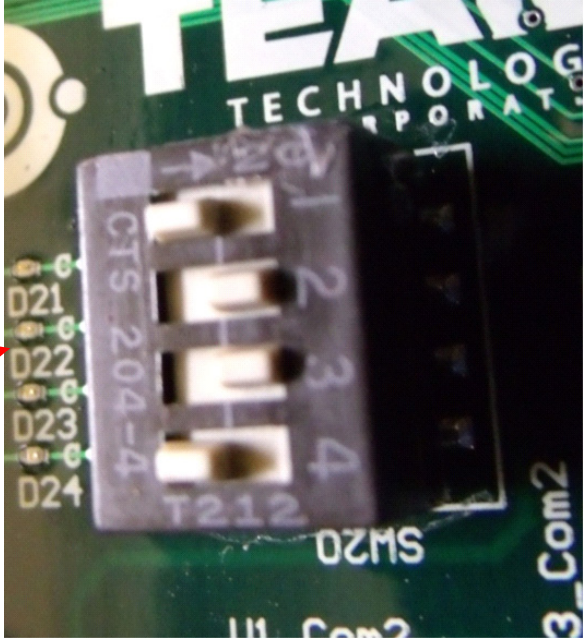

SECTION 3 Cab Control System

Character 9 (B): This Character is for the PUMP Coil Voltage setting, located on the Master Board Tank Configuration DIP Switches. It is set to the specific voltage or amperage outputs of the system to operate the pump activation electrical circuit. Switches 3, 4, and 5 of the Master Board Tank Configuration DIP switches control this feature. If an incorrect setting is programmed, the hoist valve solenoid coil will fail, causing the hoist valve to not operate.

- CHARACTER 9**
PUMP COIL VOLTAGE, WITHOUT SUCTION LOAD OPTION
- A-SW3 OFF/SW4 OFF/SW5 OFF, VALVE LIMITED TO ABOUT 5V RMS
 - B-SW3 ON/SW4 OFF/SW5 OFF, VALVE LIMITED TO ABOUT 1.93A RMS
 - C-SW3 OFF/SW4 ON/SW5 OFF, VALVE LIMITED TO ABOUT 0.8A RMS
 - D-SW3 ON/SW4 ON/SW5 OFF, 24V
- PUMP COIL VOLTAGE, WITH SUCTION LOAD OPTION
- E-SW3 OFF/SW4 OFF/SW5 ON, VALVE LIMITED TO ABOUT 5V RMS
 - F-SW3 ON/SW4 OFF/SW5 ON, VALVE LIMITED TO ABOUT 1.93A RMS
 - G-SW3 OFF/SW4 ON/SW5 ON, VALVE LIMITED TO ABOUT 0.8A RMS
 - H-SW3 ON/SW4 ON/SW5 ON, 24V

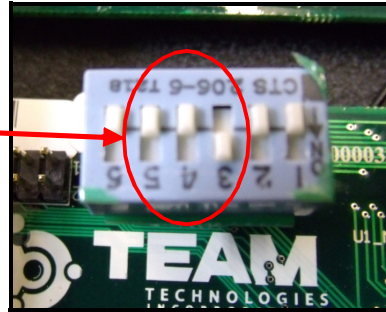

Character 10 (2): If AUTO is UNINSTALLED, then Tank Configuration DIP Switch #6 must be in the OFF position. Otherwise, the AUTO light on the master switch box will blink. Turning Switch #6 OFF will ensure that the AUTO light remains off if AUTO mode is not installed. If AUTO mode is added at a later date, Switch #6 must be turned ON at that time.

- CHARACTER 10**
- 1-SW6 ENABLE ISCS
 - 2-SW6 DISABLE ISCS
- Switch #6 must be in the OFF position if AUTO is uninstalled, and in the ON position if AUTO is installed.

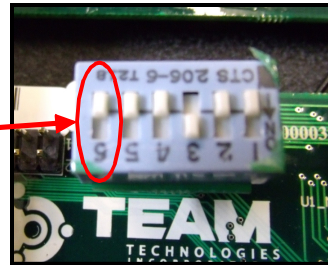

Master Switch Box Boards, Joystick Box, & ISCS Address Switch Settings

The following table shows the default settings of the Master Board, Switch Box Board, Joystick Board (identical in appearance to the Switch Box Board), and ISCS (AUTO mode-specific board). These default settings should be preset and remain unchanged so as to obtain proper system operation. These settings allow the Master Board the ability to identify specific components and their actual locations.

Module	Type	LIN address	S1	S2	S3	S4
Master Board	Digital	N/A	N/A	N/A	N/A	N/A
Switch Box Board	Analog	1	ON	OFF	ON	ON
Joystick Box	Analog	2	OFF	OFF	ON	ON
ISCS (Ground Speed Module)	Digital	6	ON	OFF	OFF	ON

EXAMPLE:

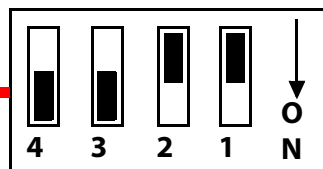
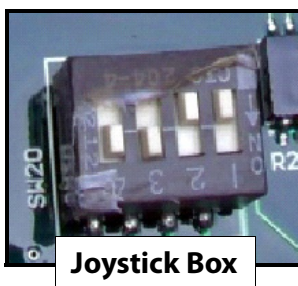

SECTION 3 Cab Control System

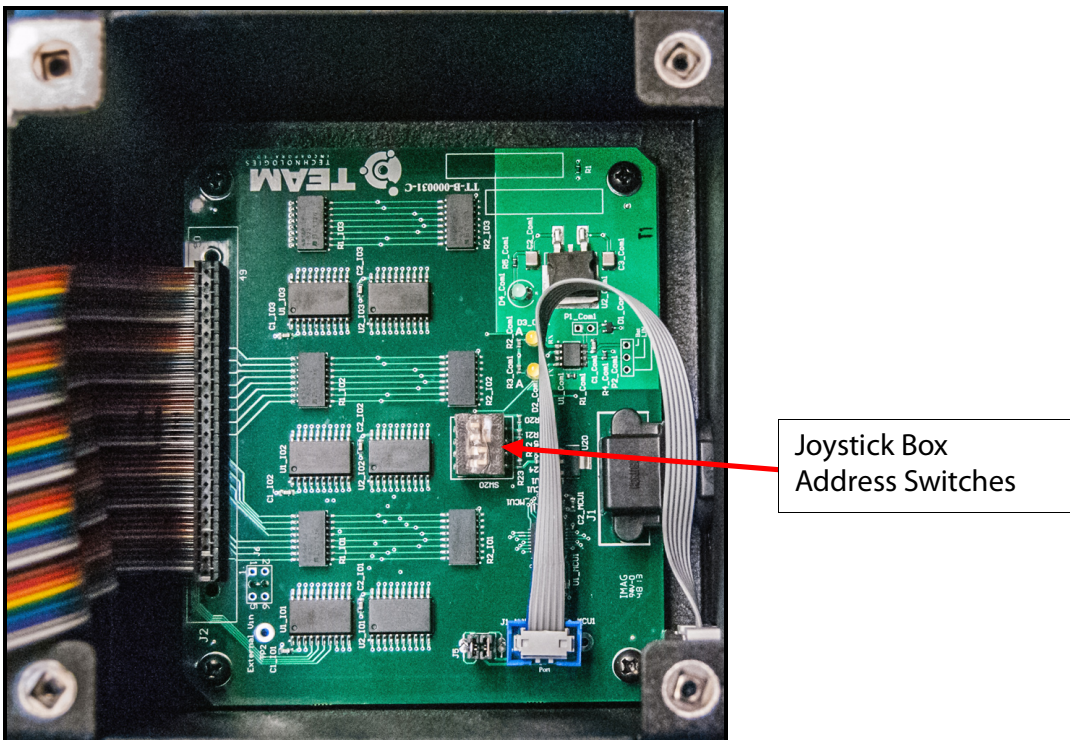
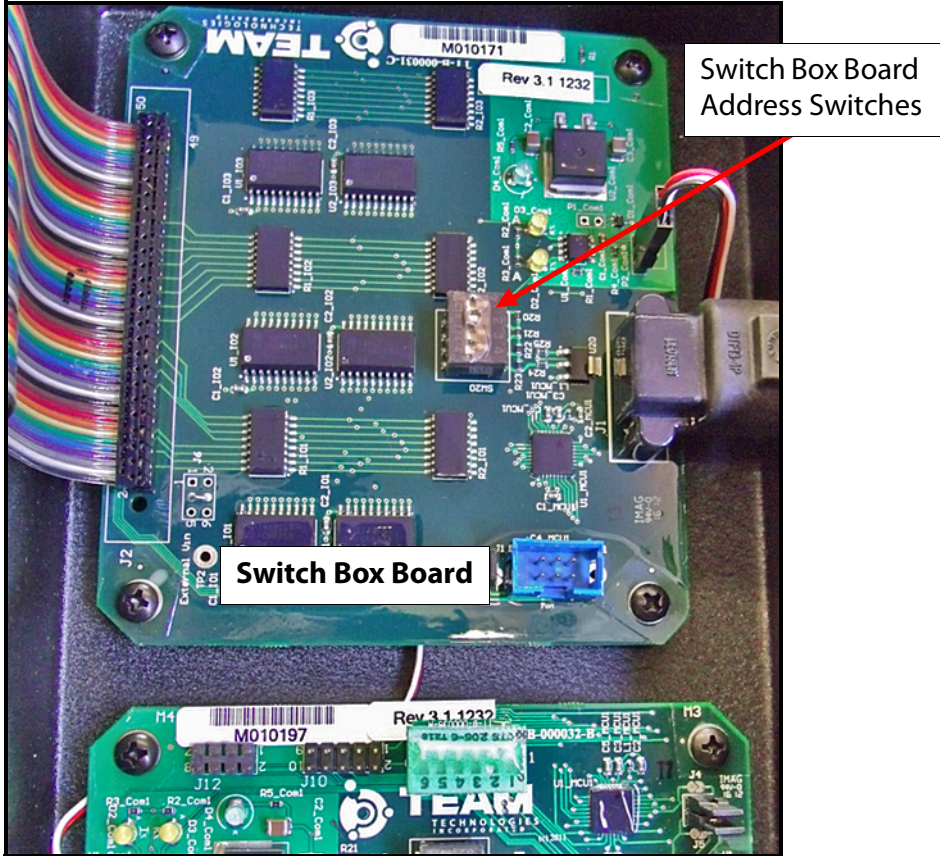

SECTION 3 Cab Control System

Solenoid Box Logic Controller Configuration & Address Switch Settings

The following describes the component locations of a typical controller, the default address settings, and procedures for configuring the correct address settings on a replacement controller.

Shown below is a typical controller. Three (3) such controllers are located on the inside of the Solenoid Control Box lid. Each individual controller is programmed with a specific address. If the address is set incorrectly, then the system **will not operate** properly.

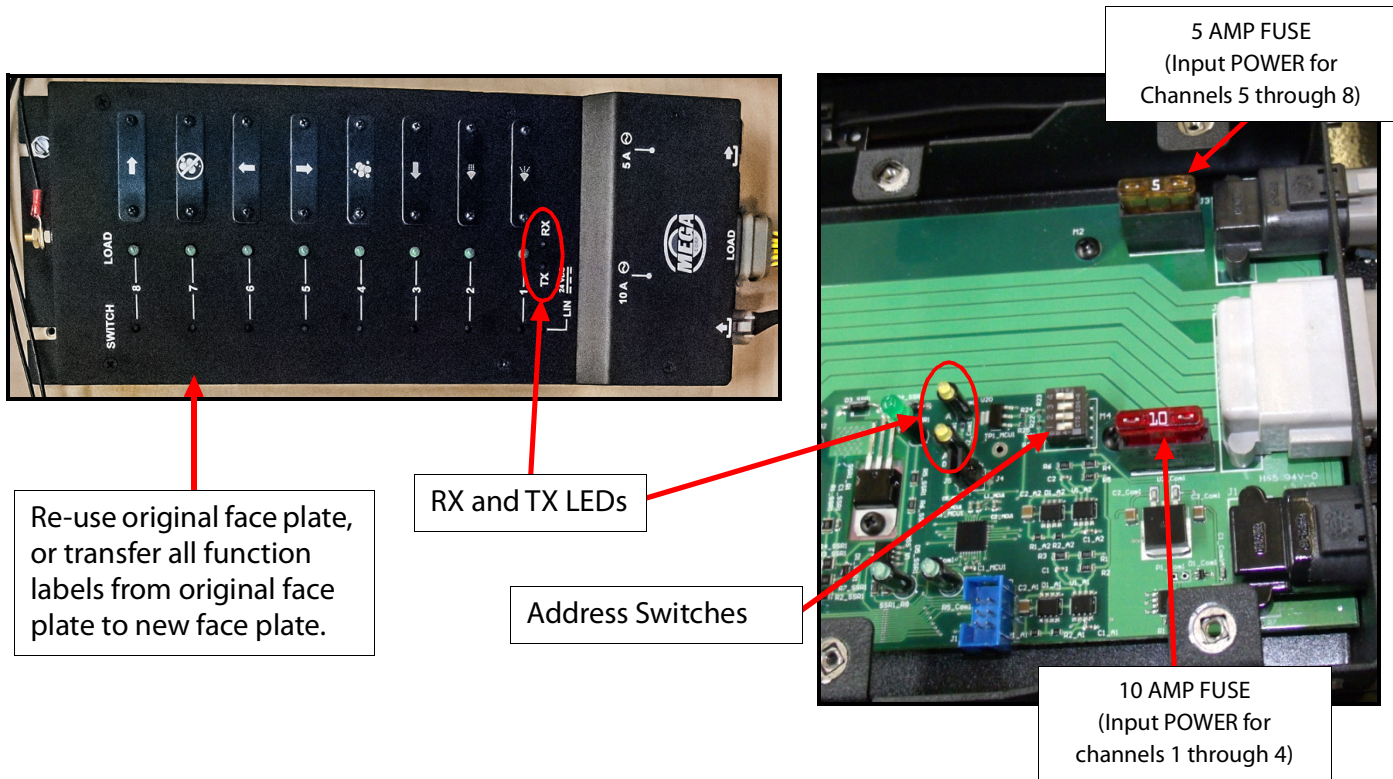

Controller Replacement and Address Configuration

1. Identify the defective controller.
2. Remove face plate from defective controller and install on the replacement controller (Part # 306662).
3. Verify the controller number by the part number on the ID tag. E.G; Controller 1 – 306403, Controller 2 – 306404, Controller 3 – 306405.
4. Using the following address chart and illustrations, change the address switch settings to match the original controller.
5. Ensure that the same software revision is installed on new controller (refer to REV level number on side of controller and on the circuit board).
6. Reinstall small controller cover over fuses and address switches.
7. Remove and replace controller, ensure ground is installed correctly on case.
8. Reconnect LIN and output connectors.
9. Fill unit with water and test all functions.

CAUTION

Ensure that a correct address is set. If an incorrect address is set, the controller will not function properly.

SECTION 3 Cab Control System

Controller Address Switch Settings

The following table shows the default address settings for the three (3) Controller Boards. These addresses are preset at Mega Corp prior to shipment. If a controller is replaced, then the replacement controller's address should be set according to this table:

Module	Type	LIN address	S1	S2	S3	S4
Controller #1	Analog	3	OFF	OFF	ON	ON
Controller #2	Analog	4	ON	ON	OFF	ON
Controller #3	Analog	5	OFF	ON	OFF	ON

Example:

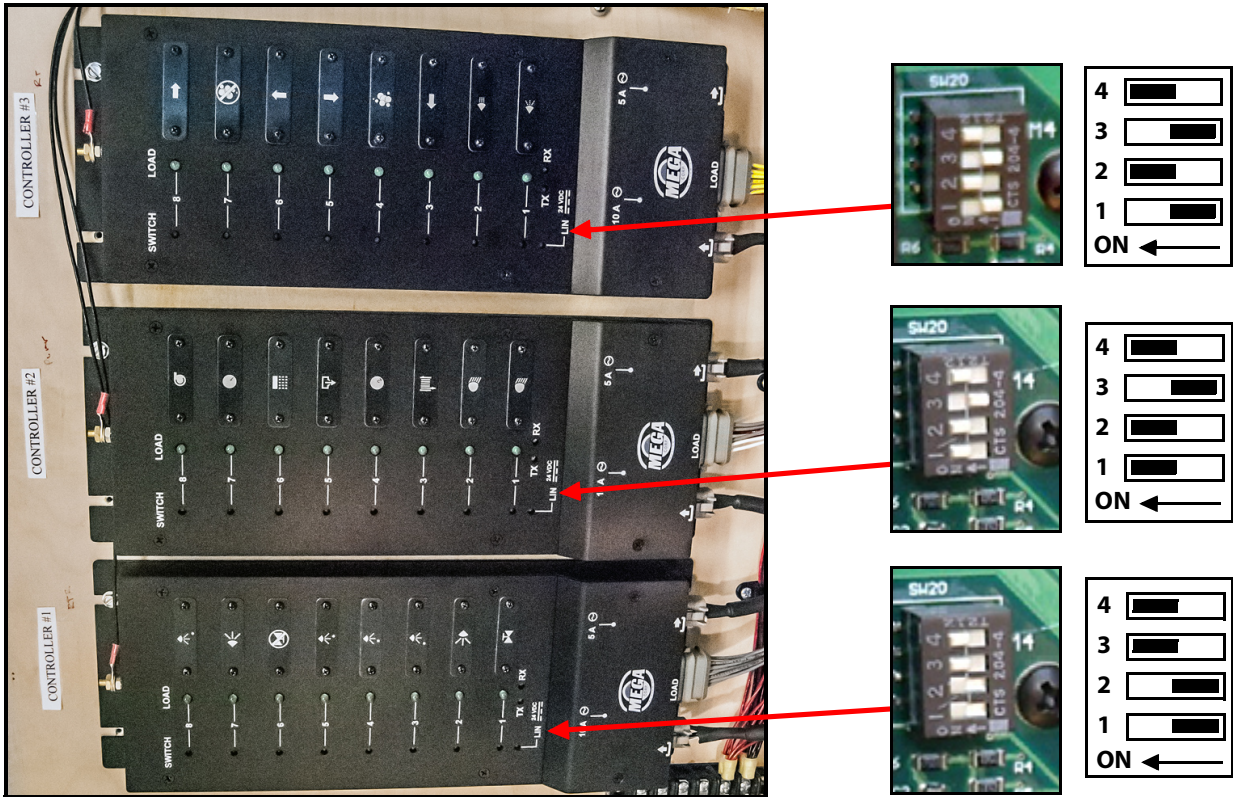

Part Numbers

- Controller 1 – 306403
- Controller 2 – 306404
- Controller 3 – 306405

NOTE

If you are having problems or do not understand the procedures please contact the MEGA Corp. Product Support Group at:

US Toll free: 1-800-345-8889
 Direct: 1-505-345-2661

Or visit our website at www.megacorpinc.com for more detailed contact information.

SECTION 3

Cab Control System

TROUBLESHOOTING (DISCS®1.5 ONLY)

Description

The inspection and troubleshooting guide to locating the root cause of a failure or performance issue.

Cab Controls

No LEDS flashing on switch box when ignition is first turned on

1. Check for 24 VDC power into switch box #2.
2. Check SYSTEM control power – Check fuse or circuit breaker.
3. Check for power to J2.
4. Check pins in cable connectors and ensure connectors are seated properly.

Switch box LEDS flash when ignition is first turned on, but joy stick box LEDS do not

1. Verify all LIN bus cables are properly connected.

Neither switch box nor joy stick box LEDS flash when ignition is first turned on, but controller TX and RX LEDS blink

1. Verify internal LIN bus cable is connected between MASTER and SLAVE boards

Controller TX and RX LEDS are not blinking on system power up

1. Verify all LIN bus cables are properly connected.
2. Verify all programming jumpers are installed and are in the correct orientation on controllers not responding.

One or more controller shows no LIN bus power LED after system power up

1. Verify all LIN bus cables are properly connected

Some controller/boxes show RX and TX LEDS blinking (not all)

1. Verify all LIN bus cables are properly connected.
2. Verify all programming jumpers are installed and are in the correct orientation on controllers not responding.

Some controllers/boxes show irregular blinking of RX and TX LEDS

1. Verify all LIN bus cables are properly connected.
2. Verify all programming jumpers are installed and are in the correct orientation on controllers not responding.

When system power switch is ON, no large green LEDS illuminate on controller #1

1. Check and verify +24 VDC power to controllers.
2. Check output fuses on affected controllers/channels.

More than 1 channel turns on when a selected spray head switch is turned on

1. Verify GROUND wire is connected to each controller and GROUND connection to chassis is good (use DVOM to confirm GROUND quality).

LEDS in switches turn on and off erratically

1. Verify GROUND wire is connected to each controller and GROUND connection to chassis is good (use DVOM to confirm GROUND quality).
2. Verify firmware revision levels are compatible (Ensure all are same level and are up to date with current level).

Some channels on a controller show small LED ON but large LED does not illuminate when commanded to activate

1. Check output fuses on affected controllers/channels.

SECTION 3

Cab Control System

Water level display does not show full when tank is full

1. Verify correct settings of switch '**Water Level DIP Switch**' in switch box.
2. Verify integrity of cable to sensor and sensor cable connections.

Water pump does not turn on when commanded

1. Verify water level is ABOVE EMPTY and cycle PUMP switch OFF and ON.

CAUTION

Do not engage/disengage the water pump above LOW IDLE. Engaging/disengaging the water pump above low idle will result in water pump component damage and reduced service life.

2. Ensure PUMP cable is connected properly.
3. Ensure system is configured for WATER TANKER operation.
4. Ensure water pump is in operational condition.
5. Ensure hoist valve solenoid/actuator is in operating condition and not damaged.
6. Verify PUMP controller LED is illuminated when PUMP is commanded to activate.

All LEDS flashing on switch boxes

1. Verify internal LIN bus cable is connected between MASTER and SLAVE boards.
2. Verify ALL programming jumpers are installed and are in the correct orientation on controllers not responding.

Controller channels respond to commands, but commanded functions do not operate

1. Ensure sufficient water is in tank and water level gauge reads above EMPTY.
2. Ensure all output power fuses are in operational condition.
3. Ensure solenoid coils are receiving proper 24 VDC power and ground signals.
4. Check and ensure solenoid control box oil filter is not restricted or needs service.
5. Check and verify solenoid control box is receiving more than 500 PSI (3,500 kPa) of oil pressure.
6. Check and ensure solenoid control box has less than 100 PSI (675 kPa) of back pressure on return.
7. Ensure water pump is operational.

Controller channels do not respond to commands

1. Verify address switch settings on all controllers.

Controller channels 1 through 4 do not operate, large and small LEDS do not illuminate, matching function switch LEDS do not illuminate

1. Remove affected controller fuse cover and check 10 AMP fuse.
2. If fuse is bad, check for excess current draw on solenoid coils for functions 1 through 4 (a shorted coil power wire to ground or an internal short in the coil).

Controller channels 5 through 8 do not operate, large and small LEDS do not illuminate, matching function switch LEDS do not illuminate

1. Remove affected controller fuse cover and check 5 AMP fuse.
2. If fuse is bad, check for excess current draw on solenoid coils for functions 5 through 8 (a shorted coil power wire to ground or an internal short in the coil).

SECTION 3

Cab Control System

Output LED does not illuminate when command LED is on

1. Check + 24 VDC power to controller(s).
2. Check output fuses on affected controllers/channels.
3. Verify GROUND wire is connected to each controller and GROUND connection to chassis is good (use DVOM to confirm GROUND quality).
4. Verify solenoid coil is good (operational).
5. Verify all output connectors on controllers are properly seated.

Switch "feels" loose or does not maintain position

1. Replace switch.

Controller fuses fail repetitively

1. Verify all electrical components and circuits to ensure they are not overloaded.
2. Ensure all electrical cables are secure and not damaged.

Water level gauge reads empty when tank contains sufficient water (greater than 25% capacity)

1. Check water level cable and connectors to ensure they are properly seated and not damaged.
2. Ensure water level port on tank is not plugged with debris.

Water pump ramps up or down at incorrect rate

1. Verify correct setting of 6 switch DIP switch in main switch box.

Water pump does not turn on after low water protection has disengaged pump, pump light flashing and water level reads above empty

1. Turn PUMP switch to OFF position.

CAUTION

Do not engage/disengage the water pump above LOW IDLE. Engaging/disengaging the water pump above low idle will result in water pump component damage and reduced service life.

2. Turn POWER Switch OFF.
3. Turn POWER Switch ON.
4. Turn PUMP switch ON.

No controller or switch box function lights illuminate when requested (large and small LEDS)

1. Check and ensure main power fuse in solenoid control box is good.
2. Check and ensure all wiring is not damaged or shorted to ground.
3. Ensure all power connections are receiving a good 24VDC signal.
4. Ensure all ground are intact and a good chassis ground is present.

Switch box lights do not illuminate when key switch is turned ON

1. Check and ensure cab control box power fuse is good.
2. Check and ensure switch box power connector is fully seated.

SECTION 3

Cab Control System

Spray Heads

Spray head is OPEN when cab control switch is OFF and CLOSED when the cab control switch is ON.

1. Ensure spray head hydraulic supply hoses are installed correctly. See Section 8 Appendix.

Spray head does not OPEN or CLOSE

1. Ensure the cab control SYSTEM switch is ON, PUMP switch is ON and the oil is flowing to the water pump hydraulic drive motor.
2. Ensure water pump rotation is correct (CW).
3. Ensure tank contains sufficient water to discharge from spray heads.
4. Ensure Guide Disk, Drop-ins and guide disk seats are not damaged.
5. Ensure hydraulic cylinder is properly adjusted.
6. Ensure Upper Housing vent is free from obstructions and vent to atmosphere.
7. Ensure solenoid control box is receiving proper hydraulic oil pressure (above 400 PSI or 2,750 kpa).
8. Ensure solenoid control box hydraulic oil filter is clean and by-pass filter minder is GREEN. If filter minder is RED, remove and service/replace filter as needed.
9. Ensure hydraulic solenoid coil for function(s) malfunctioning are receiving proper 24 VDC and ground signals.

Spray head flow and pattern does not meet desired application

1. Adjust spray head deflector ring opening (1/4" or 3/8") and/or fan adjustment (full or partial fan) to meet desired spray pattern.
2. Ensure tank contains sufficient water to operate spray heads properly.
3. Increase or Decrease engine RPM, selected gear or ground speed to achieve desired spray and flow pattern.
4. At HIGH IDLE, ensure water pump speed is set to:
M4 PUMP: 1900 ± 50 RPM
M4B PUMP: 1950 ± 50 RPM

CAUTION

Water pump RPM must not exceed the above specifications with engine at high idle. Failure to ensure water pump speed is at or below specifications will result in reduced spray system component service life.

Spray head flow stops when water pump is ON and spray head is OFF and leaks when system or engine is OFF

1. Inspect and insure spray head upper housing vent tube is clear and free from obstructions, repair or clean as required.

SECTION 3

Cab Control System

For Units Equipped With Ground Speed Sensing Option (GPS)

Spray heads will not operate when vehicle is stopped (less than 3 mph/4.8 kph), and it is desired that the spray heads operate at and below this threshold

1. Ensure the '**AUTO**' switch is in the OFF position.

NOTE

This is the LOW SPEED CUTOFF for the AUTO function of the DiSCS[®] with ground speed sensing option. The pump will automatically engage when vehicle speed is observed ABOVE 3 MPH and AUTO function will resume. See the DiSCS[®] AUTO operations for detailed information about this function and its settings.

Auto LED always flashes

1. Check and verify GPS, cable and mount are connected properly and intact and installed properly.

NOTE

If system appears to malfunction, place vehicle in a secure location, set park brakes and shut spray system OFF beginning with all output functions, then, with Engine at LOW IDLE shut PUMP OFF followed by the SYSTEM/POWER switch. When Spray system has been turned OFF, shut Engine OFF. Then restart Engine and ensure tank is full of water. With Engine at LOW IDLE turn SYSTEM/POWER switch ON, turn PUMP switch ON and check system functions. A full system restart may be required to ensure all system functions are in operating condition.

CAUTION

If you are having trouble understanding or cannot find the symptom of the condition in this document, immediately contact the MEGA Corp. Product Support Group at:

US Toll free: 1-800-345-8889

Direct: 1-505-345-2661

Or visit our website at www.megacorpinc.com for more detailed contact information.

Water Level Sensor Cable Replacement

1. Disconnect old water level sensor cable at the solenoid control box and the water level sensor at the rear of the tank.
2. Insert loose end of the replacement water level sensor cable through the strain relief in the pipe cap from the **inside out**, as shown below:

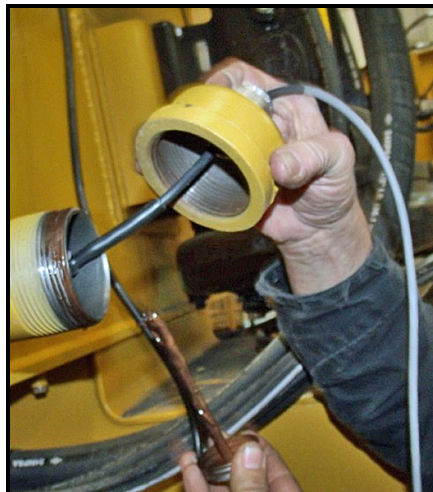

3. Connect water level sensor pigtail connector to water level cable connector and place inside tube.
4. Thread pipe cap on protective pipe until snug.

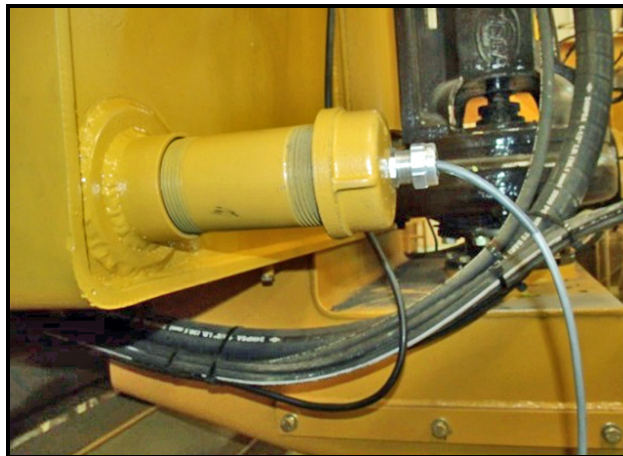

5. Tighten strain relief around cable, take care to not tighten strain relief too tight to damage cable.

SECTION 3

Cab Control System

- Route water level cable along spray head hosing to the solenoid box on the front bulkhead of the tank.
- Insert pre-terminated sockets into 4 pin plug as follows:

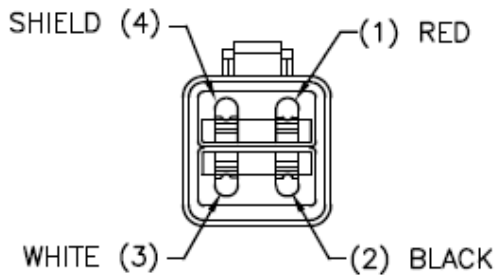
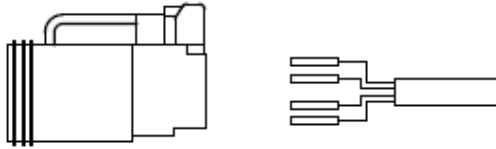

- Identify the measurement in inches and refer to the water level gauge calibration chart on page 5. If you are unsure of the tank height contact the MEGA Product Support Group with the tank model and serial number for assistance.
- Confirm that the DIP Switch settings are correct for the tank height.
- Check all water level gauge cables and connectors.
- Ensure that the water level sensor tube and connector is clean and dry. If it is wet and/or the tube is full of water, ensure that the drain hole is not plugged, that there are 2 additional drain holes in the bottom of the tube to allow water not to collect, and that the sensor is properly sealed.

- Secure excess cable and plug into water level receptacle.
- Calibrate the water level sensor DIP switch bank according to the procedures on page 61.

Water Level Gauge Troubleshooting and Repair

The following procedures will explain the troubleshooting and replacement of the DiSCS® water level gauge.

- The water level gauge EMPTY red light will blink in unison with the PUMP switch LED, indicating that the tank is EMPTY. This can be used as a reference to the fuse in the water level gauge circuit is bad, the water level sensor cable has an open circuit or the water level sensor has failed. The following steps will identify these conditions to reach a reasonable conclusion for repair.
- Verify the volume of water in the tank. This can be done by measuring the water from the bottom of the main tunnel to the level of the water by using a string and weight lowered into the tank through the main fill port on the top of the tank. It is recommended that the tank is filled to capacity for level verification.

SECTION 3

Cab Control System

7. Check the water level fuse inside of the solenoid control box as shown in the picture below.



8. Ensure that the 5 AMP ATC style fuse is good and properly seated. If fuse is blown, check for a power to ground short circuit using the following procedure:
- a. Disconnect water level sensor cable at the solenoid control box and the water level sensor at the rear of the tank.
 - b. Using a DVOM Multi-meter on the OHM setting, check for continuity between:
 - The *red* to *black* wires (pins 1 to 2),
 - The *red* to *white* (pins 1 to 3) wires
 - The *red* to *shield* wires (pins 1 to 4)
 - The *white* to *black* wires (pins 2 to 3)
 - The *red* wire to the *water tank ground* (pin 1 to tank)
 - The *white* wire to the *water tank ground* (pin 3 to tank).

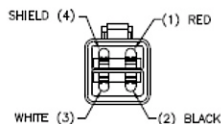
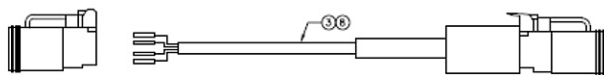

- c. There should be NO CONTINUITY between any of the wires. If there is any continuity detected between any of the wires, replace the water level sensor cable.
 - d. Reconnect system, replace fuse with a 5 AMP ATC style fuse only.
 - e. Retest water level gauge.
9. If fuse is good and gauge reads EMPTY and is flashing, or reads incorrectly when the calibration DIP switch settings are in the correct position for the height of the tank, use the following procedure.
- a. Verify tank is full of water.
 - b. Check water level sensor cable and connections for security and damage.
 - c. Check water level sensor to ensure there is no water or corrosion damage to sensor or connectors.
 - d. Manufacture a break out wiring harness to ensure sensor is installed correctly when taking voltage readings. If sensor is disconnected, voltage readings may be in error leading to an incorrect diagnosis.
 - e. Measure voltage between *red* wire and *black* wire (pins 1 and 2), ensure 24 VDC is observed. If 24 VDC is not present contact the MEGA Product Support Group with the tank model and serial number for assistance at:

US Toll free: 1-800-345-8889
 Direct: 1-505-345-2661

Or visit our website at www.megacorpinc.com for more detailed contact information.

SECTION 3

Cab Control System

- f. Follow the Voltage table below to verify water level sensor output voltage.

HEIGHT OF WATER COLUMN (INCHES)	VDC ON WHITE WIRE (PIN 3) TO BLACK WIRE (PIN 2)
150	3.6125
140	3.3717
130	3.131
120	2.890
110	2.6492
100	2.408
95	2.2879
90	2.1675
85	2.0471
80	1.9267
75	1.80625
70	1.6858
65	1.5654
60	1.445

- g. If water level gauge reads empty check for an OPEN circuit on the *red*, *black*, and *white* wires by disconnecting both the water level sensor and the plug at the solenoid control box and building a jumper wire to go between 2 of the pins on one end of cable and measuring the resistance of the circuit at the other end at the same 2 pins. This should verify that all wires are intact and in operating condition.
10. If water level gauge reads erratically or inaccurately at all levels, check all wiring connectors and wiring for corrosion or damage. Refer to the voltage chart to ensure voltage output is correct for the water column to verify sensor output. If sensor output is different than what is found on the chart, replace water level sensor and check water level gauge accuracy again.

If you are having trouble understanding the procedure contained in this document, immediately contact the MEGA Corp. Product Support Group for assistance.

SECTION 3
Cab Control System

SECTION 4A

Basic Hydraulics System (MAC/MAT, MTT/MWT)

Contents

Description	4A-1	Oil Cooler (If Equipped)	4A-2
Tank Mounted Hydraulic Manifold	4A-1	Butterfly Valve (BFV)	4A-2

DESCRIPTION

The MAC/MAT and MTT/MWT hydraulic system is comprised of manifolds, diverters, control valves, solenoids and hosing to provide hydraulic oil flow to tank components. Hydraulic flow is required to operate the water pump hydraulic drive motor, hydraulic spray heads, solenoid control box, hydraulic BFVs and monitor hydraulic motors.

TANK MOUNTED HYDRAULIC MANIFOLD

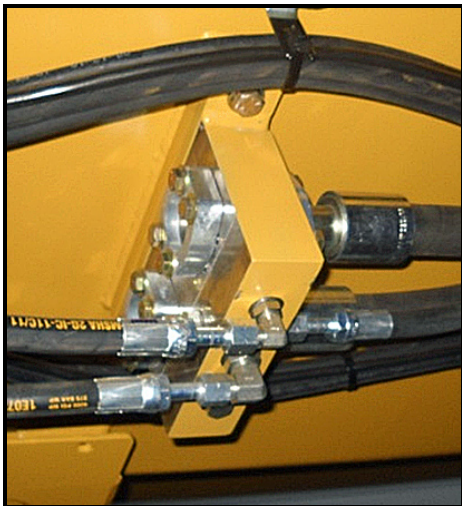

Description

A manifold that provides attaching points for system hosing for both pressure and return oil flow. The manifold is mounted to the lower front section of the tank tub.

Inspection

1. Inspect manifold for security and cracks.
2. Inspect elbows, adapters and flanges for leaks and damage.

Repair

If your system is not covered in this manual or you require more detailed repair information please contact the MEGA Corp. Product Support Group at:

US Toll Free: 1-800-345-8889
 Direct: 1-505-345-2661

Or visit our website at www.megacorpinc.com for more detailed information.

Flange Seal Replacement

1. Ensure vehicle hydraulic system is not in operation.
2. Disconnect leaking flange assembly.
3. Replace flange o-ring and reinstall flange assembly.
4. Pressurize hydraulic system and check for leaks as well as component operation.

Tank Hydraulic Manifold Replacement

1. Ensure vehicle hydraulic system is not in operation.
2. Disconnect all flange assemblies.
3. Remove manifold mount bolts.
4. Install new manifold and mount bolts.
5. Replace all flange fitting o-rings and reinstall flanged fittings.
6. Pressurize hydraulic system and check for leaks.

SECTION 4A

Basic Hydraulics System (MAC/MAT, MTT/MWT)

OIL COOLER (IF EQUIPPED)



An air-cooled oil cooler is located near the top front bulkhead of the water tank. Hot oil from the drive motor return passes through the cooler, which uses forced air to cool the oil before returning the water to the water tank.

Inspection

1. Inspect mounting daily for security.
2. Inspect hose connections and oil cooler daily for leaks and damage.

Repair

Hydraulic Hosing

If hosing is damaged or leaking, repair as required.

Cooler Structure

If oil cooler structure is damaged, contact Mega Product Support at:

U.S. Toll Free: 1-800-345-8889

Direct: 1-505-345-2661

Or visit our website at: www.megacorpinc.com for more contact information.

BUTTERFLY VALVE (BFV)

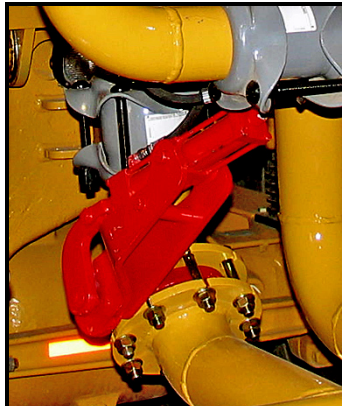

Description

A hydraulically operated valve that opens or closes to control water flow to dump bars, tank drain or quick drain operations. The hydraulic cylinder receives hydraulic pressure from a hydraulic solenoid control box normally mounted on the aft tank bulkhead above the spray bar.

Inspection

Inspect BFV assembly and hosing for security and leaks.

Repair

BFV Removal

1. Ensure vehicle hydraulic system is not in operation.
2. Remove water piping bolts that clamp BFV between the piping flanges.
3. Label and disconnect hydraulic extend and retract hoses from BFV hydraulic cylinder and cap hydraulic lines.

BFV Installation

1. Position BFV between the water piping flanges and install clamping bolts.
2. Tighten clamping bolts equally to secure BFV between pipe flanges.
3. Connect hydraulic extend and retract hoses to the BFV cylinder.
4. Pressurize hydraulic system and check for leaks as well as component operation.

SECTION 4A

Basic Hydraulics System (MAC/MAT, MTT/MWT)

BFV Disassembly/Inspection & Reassembly

1. Remove clevis and cotter pin from hydraulic cylinder.
2. Loosen set screw on waterway valve and remove bellcrank.
3. Loosen all 4 BFV bracket mount bolts and disassembly brackets from the cylinder and waterway valve.
4. Inspect hydraulic cylinder for leaks.
5. Inspect waterway rubber seal for wear, cuts and condition.
6. Locate hydraulic cylinder pivot pins in side brackets.
7. Position waterway valve between side brackets and install 4 BFV bracket mount bolts.
8. Tighten BFV bracket mount bolt evenly while ensuring hydraulic cylinder still rotates freely on the pivot pins.
9. Install bell crank on waterway valve shaft and tighten set screw.
10. Install clevis and cotter pin.

If your system is not covered in this manual or you are having difficulties with the installation or repair, please contact The MEGA Corp. Product Support Group at:

U.S. Toll Free: 1-800-345-8889

Direct: 1-505-345-2661

Or visit our website at: www.megacorpinc.com for more contact information.

SECTION 4A

Basic Hydraulics System (MAC/MAT, MTT/MWT)

SECTION 4B

Basic Hydraulics System (MST/MSC)

Contents

Description	4B-1
3-Way Hydraulic Control Valve	4B-1
Inspection	4B-1
Repair	4B-1

DESCRIPTION

The MST/MSC hydraulic system originates at the CAT tractor hydraulic pump mounted on the right side of the tractor transmission. Hydraulic pressure is then routed to the MST/MSC 3-way hydraulic control valve assembly where pressure is regulated and controlled for the water pump drive motor and other water tank accessories.

3-WAY HYDRAULIC CONTROL VALVE



The hydraulic control valve consists of manifolds, pressure relief cartridge and a piloted solenoid control valve. The manifolds provide passage ways for hydraulic flow while allowing mounting for a relief valve cartridge and a piloted operated solenoid valve. Pilot pressure is supplied from hitch cushion.

The valve pressure relief manifold is set to 2000 psi +/- 50. The piloted solenoid control valve opens and closes to control regulated hydraulic pressure for the water pump drive motor. The solenoid valve is 24 VDC and is commanded by the cab control pump switch.

INSPECTION

1. Inspect manifold for security, cracks and leaks.
2. Inspect elbows, adapters and flanges for leaks and damage.
3. Inspect relief valve for security and leaks.

4. Inspect piloted operated solenoid control valve and wiring for security, wear and leaks.

REPAIR

Flange Seal Replacement

1. Ensure vehicle hydraulic system is not in operation.
2. Disconnect leaking flange assembly.
3. Replace flange o-ring and reinstall flange assembly.
4. Pressurize hydraulic system and check for leaks as well as component operation.

Manifold Replacement

1. Ensure vehicle hydraulic system is not in operation.
2. Disconnect all flange assemblies.
3. Remove electrical cables
4. Remove mount bolts and 3-way valve.
5. Install new valve assembly and mount bolts. Torque bolts to standard torque value.
6. Replace all flange fitting o-rings and reinstall flanged fittings.
7. Reconnect electrical cables.
8. Pressurize hydraulic system and check for leaks as well as component operation.

SECTION 4B

Basic Hydraulics System (MST/MSC)

Pressure Relief Valve Replacement



1. Ensure vehicle hydraulic system is not in operation.
2. Remove relief valve.
3. Install relief valve.
4. Start up machine and pressurize the system.
5. Set relief valve pressure to 2000 +/- 50 psi.
6. Once relief valve is adjusted, secure relief valve jam nut.
7. Ensure relief valve is not leaking.
8. Shutdown the machine.
9. Service hydraulic tank as required.

Piloted Solenoid Valve Replacement

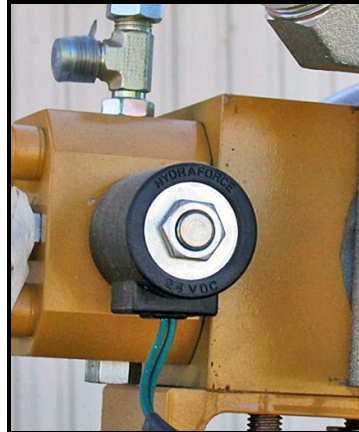

1. Ensure vehicle hydraulic system is not in operation.
2. Remove solenoid valve coil from solenoid stem.
3. Remove valve stem.
4. Install new valve stem.
5. Install new solenoid valve coil.
6. Connect solenoid valve coil to control cable.
7. Start up machine and pressurize the system. Check solenoid valve stem for leaks.
8. Ensure water pump operates normally with the cab control pump switch.
9. Shutdown the machine.
10. Service hydraulic tank as required.

SECTION 5

Water Pumps

Contents

Description	5-1	Initial Operation And In-service Of M-4 Pump.....	5-35
Hydraulic Drive Motor	5-1	M-4 Routine Maintenance.....	5-36
Drive Motor Disassembly And Reassembly	5-3	M-4 Repair (304991/304992)	5-37
Hydraulic Drive Motor Speed Control	5-13	M-4 Water Pump Reassembly.....	5-42
Hydraulic Drive Motor Activation.....	5-13	M-4B Water Pump	5-44
Water Pump Cautions.....	5-14	M-4B Routine Maintenance And Repair	5-44
Water Pump Identification.....	5-15	M-4B Water Pump Disassembly And Inspection .	5-46
M3 Water Pump	5-22	M-4B Water Pump Reassembly	5-48
M3 Water Pump Inspections	5-23	M-4/M-4B Functional Check & RPM Adjustment..	5-53
M3 Routine Maintenance And Repair.....	5-24	M-4/M-4B Water Pump RPM Adjustment	5-55
M3 Functional Check And RPM Adjustment	5-31	Water Pump Troubleshooting FAQ.....	5-56
M3 Water Pump In-service Notes.....	5-33	M-4 & M-4B Water Pump Notes	5-57
M-4 Water Pump Description	5-34		

DESCRIPTION

The water pump assembly is comprised of a hydraulic drive motor, water pump and a cross-over assembly. The water pump assembly uses vehicle hydraulic oil flow to turn the hydraulic drive motor which is directly coupled to the water pump. Water pump speed is controlled by adjusting the cross-over assembly which routes excess oil flow from the inlet port (pressure) of the hydraulic drive motor to the return oil hose for the hydraulic drive motor.

Mega water tank units are configured with different types of water pumps depending on tank capacity and customer specifications.

⚠ WARNING

Due to the nature of these processes, ensure that all safety information, warnings and instructions are read and understood before any operation or any maintenance procedures are performed. This service function takes place with heavy components and at moderate heights, so ensure all proper safety procedures and equipment are maintained when performing this service. Failure to use and maintain proper safety equipment and procedures will cause personal injury, death or damage to equipment.

HYDRAULIC DRIVE MOTOR



The M-4 pump rotates clockwise as viewed from the drive end of the assembly.

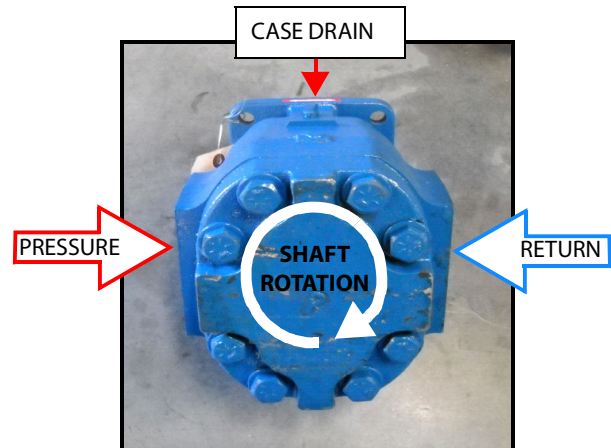

The hydraulic drive motor may be installed in 4 different orientations depending on the water pump location or application.

SECTION 5 Water Pumps

Hydraulic Drive Motor Port Identification

The hydraulic drive motor requires hydraulic flow from a valve to the motor pressure port, return oil flow to the hydraulic reservoir and a free to tank case drain.

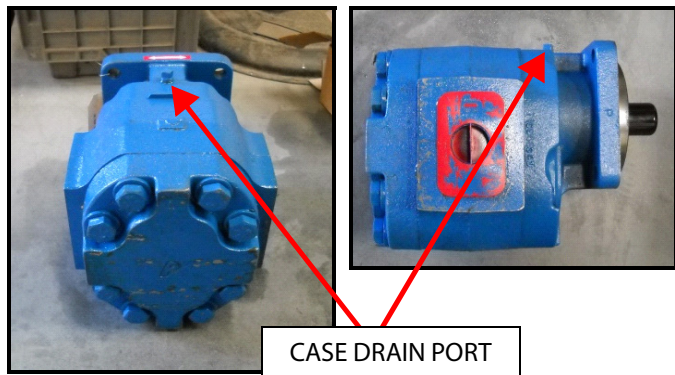

Description

A gear-type hydraulic motor mounted to the water pump bracket. The hydraulic motor receives hydraulic pressure from the vehicle hydraulic system at 12,410-23,442 kpa (1800-3400 PSI) and flow rates up 492 LPM (130 GPM) to operate. The hydraulic motor is coupled directly to the water pump shaft and rotates in a clockwise (CW) direction. The drive motor speed is controlled by the cross-over assembly that includes a flow control to reduce the volume of oil passing through the drive motor, reducing the speed.

Inspection

1. Inspect drive motor for security, leaks and overheating.
2. Inspect hydraulic manifolds, hoses, flanges and fittings for security and leaks.

Repair

Manifold Seal Replacement

1. Ensure vehicle hydraulic system is not in operation.
2. Disconnect manifold assembly.
3. Replace manifold o-ring and reinstall manifold assembly.
4. Pressurize hydraulic system and check for leaks as well as component operation.

Drive Motor Removal

1. Ensure vehicle hydraulic system is not in operation and safe for maintenance.
2. Disconnect manifold assembly and cover open ports.
3. Remove drive motor mount bolts.

Drive Motor Installation

1. Inspect water pump to drive motor coupling for wear and replace if required.
2. Mate drive motor shaft to water pump coupling.
3. Install and secure drive motor mount bolts.
4. Attach manifold assemblies and secure mount bolts.
5. Pressurize hydraulic system and check for leaks as well as component operation.

SECTION 5 Water Pumps

DRIVE MOTOR DISASSEMBLY AND REASSEMBLY

The following procedures discuss the disassembly, inspection, and subsequent reassembly of the Permco 7500 series hydraulic drive motors. If you do not understand these procedures or your drive motor is not covered, please contact the MEGA Corp. Product Support Group at:

US Toll free: 1-800-345-8889

Direct: 1-505-345-2661 or visit our website at www.megacorpinc.com for more detailed contact information.

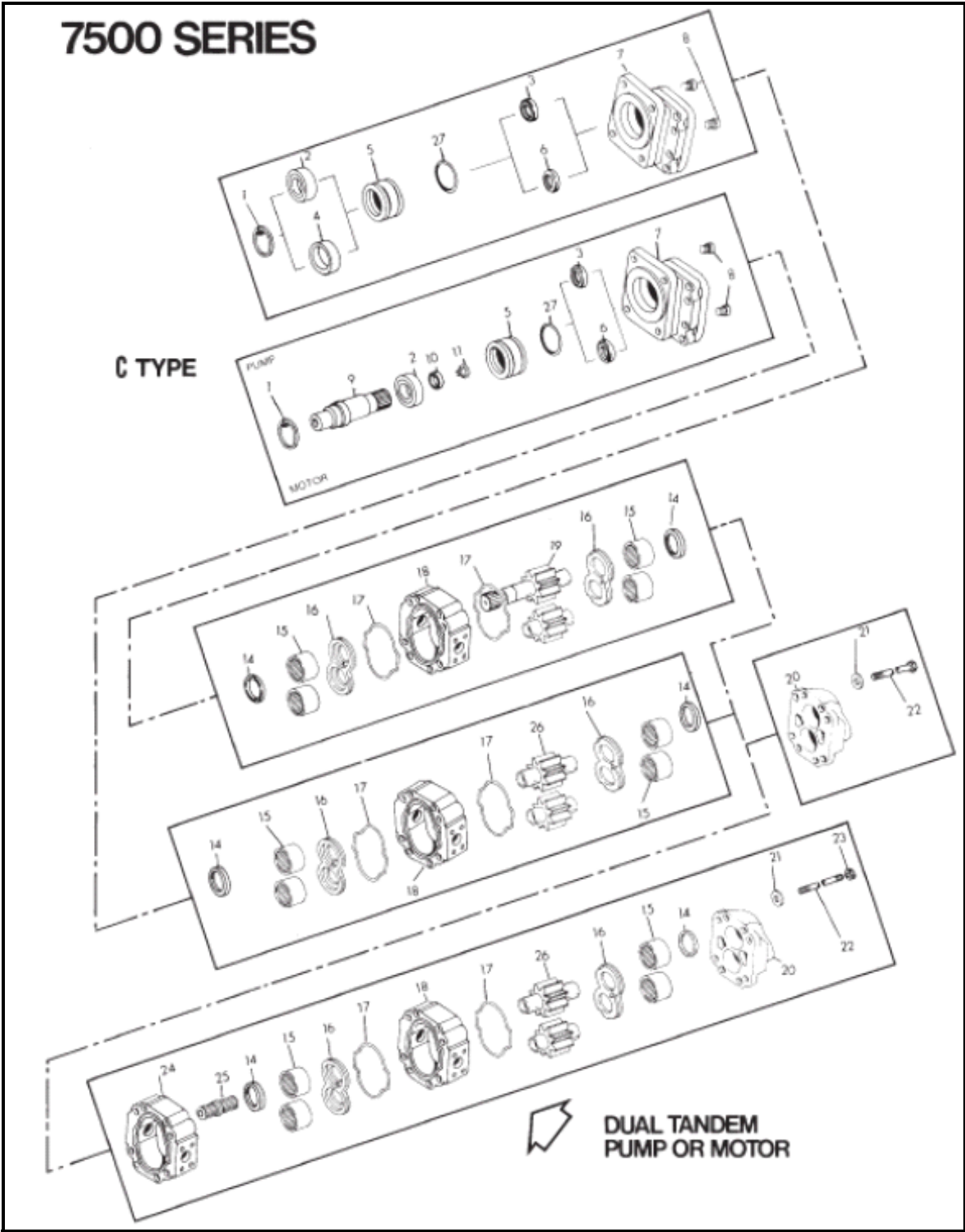

SECTION 5

Water Pumps

7500 SERIES PUMPS/MOTORS PARTS

Number	Item
1	Snap Ring
2	Outboard Bearing
3	Double Lip Seal
4	Bearing Spacer
5	Seal Retainer
6	High Pressure Seal
7	Shaft End Cover
8	Check Valve Assembly
9	Continental Shaft
10	Spacer
11	Snap Ring
14	Ring Seal
15	Crowned Roller Bearing
16	Teflon-coated Thrust Plate Diverter Plate Bi-rotational Diverter Plate
17	Gasket Seal
18	Housing
19	Drive Shaft & Gear Set
20	Port End Cover (PEC)
21	5/8" Grade 8 Washers
22	5/8-11 Grade 8 Threaded Rod
23	5/8-11 Grade 8 Hex Nut
24	Bearing Carrier
25	Connecting Shaft
26	Gear Set
27	O-Ring
28	Grade 8 Hex Head Cap Screw

Disassembly

1. With a sharp metal scribing tool, grease pencil, Magic Marker, or paint, make an indexing mark that runs straight across a surface of the port end cover (20), gear housing (18), and shaft end cover (7). This will enable you to re-assemble these parts into the same position when you put the unit back together.
2. Clamp the unit in a vise, shaft end down.

3. Remove the cap screws or threaded rod (22) and washers (21) at the rear of the unit that hold the port end cover (20) and the gear housing (18) together. Remove the port end cover (20) and diverter plate (16) **or** thrust plate (16).



The roller bearings (15) will remain with the port end cover (20). On those units with thrust plates, the pocket seals will come out easily. (Permco pumps having diverter plates do not require pocket seals).

4. Remove the pump drive gear, the driven gear, and the gear housing (18) from the shaft end cover (7).

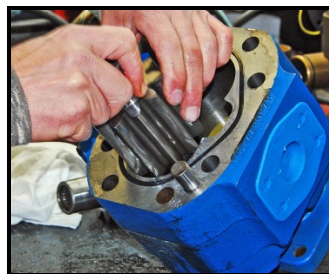

CAUTION

Keep the drive gear and the driven gear together. They must be reassembled as the original pair, since they have been worked-in together. Failure to reassemble them correctly will cause machine damage and failure.

SECTION 5

Water Pumps

Shaft End Cover (7500 Series)

1. Set the partially-disassembled unit (shaft end cover (7)) from which the gear housing has been separated in the vise, pilot-end up.

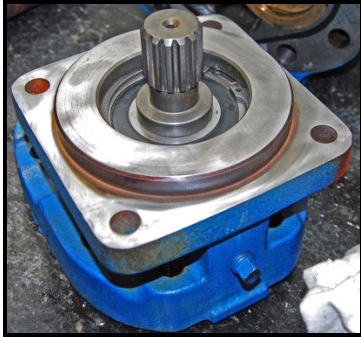

2. Remove the snap ring from the shaft end cover (7). The bearing (2) or bearing spacer (4) can now be removed. It is a slip fit. A bearing puller can be used, if necessary.



3. Remove the seal retainer (5). Discard the O-ring (27).



4. Remove the seal by inserting a curved tool between seal and seal retainer (5), tapping it out, and discarding.



5. Turn shaft end cover (7) pilot-end down in vise. Diverter plate will now be accessible.

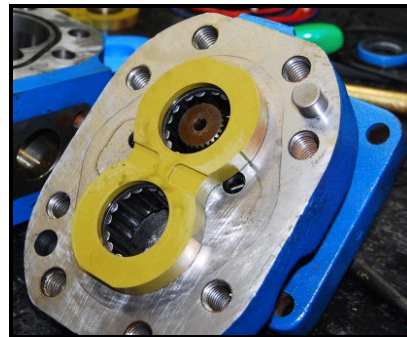

6. With a knife blade or thin-blade screwdriver, very gently pry the diverter plate (16) off the bearings of the shaft end cover (7). If working on another make of pump to be refitted with PERMCO diverter plates, remove the pocket seals and throw away. PERMCO pumps and diverter plates require no pocket seals.



SECTION 5

Water Pumps

7. If you plan to replace bearings, use a bearing puller to pull the roller bearings (15) out of the shaft end cover (7). If you pull the bearings, check bores for out-of-round condition and elliptical shape. If more than 0.003" out-of-round, **do not** use again.

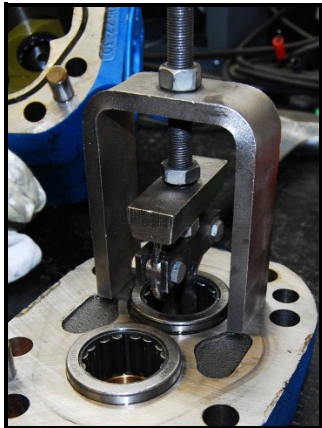

8. Examine the ring seal (14). If worn, replace by pulling the drive gear bearing.

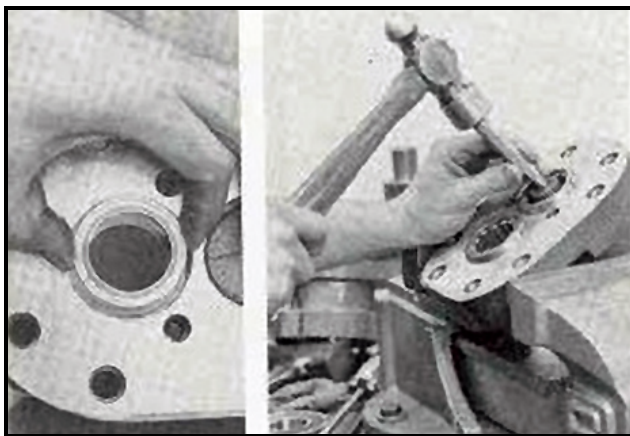

DISASSEMBLY OF TYPE "C" (CONTINENTAL) SHAFT END COVER:

Follow the steps described previously for the standard shaft end cover. However, on the Type "C" unit, the shaft (9) will be pressed out of the cover (7) along with the bearing (2).

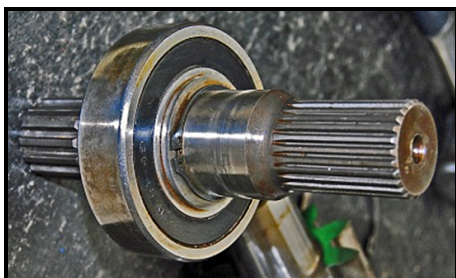

Separate the shaft (9) from the bearing (2) as follows:

- a. Remove snap ring (11) and spacer (10) from **gear** end of shaft (9).
- b. Press bearing (2) off **gear** end of shaft (9)



Gear Housing; Single Units and Multiple Units

1. Remove square gasket seals (17) from gear housing (18), and discard. Have identical replacements at hand for reassembly. **DO NOT USE O-RINGS.** Check for depth of wear in gear housing at this time; use a telescoping gauge and a micrometer. If wear pattern on gear housing exceeds 0.003", discard housing and replace with a new one.

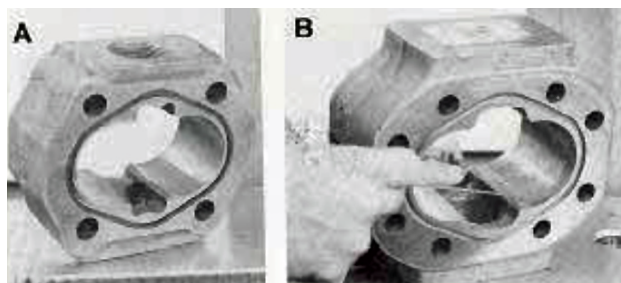

Figure A shows a satisfactory housing with little wear. Figure B shows a housing with excessive wear; notice large cavities that indicate cavitation was present.

CAUTION

Do not use O-rings for reassembly of the gear housing. O-rings do not meet the requirements for the system, and may cause damage to the gear housing if used.

SECTION 5

Water Pumps

- Examine the housing for cracks (Figure C). These may come from overpressure or by possible over-tightening of an **NPT** thread. If a new gear housing is required and a large port is present, step-drill the housing (Figure D) if PERMCO diverter plates are to be installed.

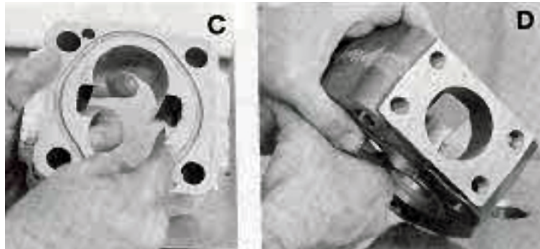

- Examine gears for wear, scuffed or pitted journals, scratched or scuffed tooth faces, or deep nicks on tooth edges. If any of these defects are present, install new drive and driven gears. Figure E shows a satisfactory gear hub, with no nicks. Figure F shows a gear hub that is breaking down from contamination, over-pressurization, pressure shock, or bearing failure.

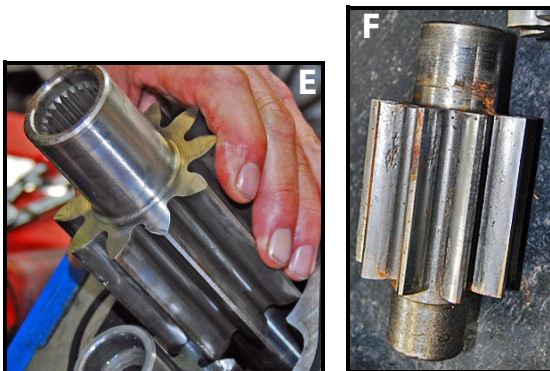

On examination of gear faces, some scratches may be found. If they can be removed by stoning, then the set can be re-used. Also examine the ring seal surface (Figure G) for wear.

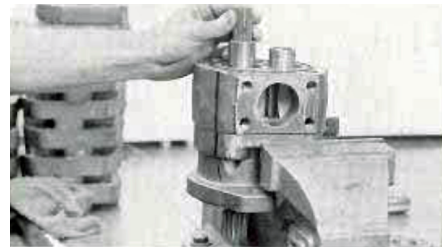

Figure H shows a rotating group that ran without oil.



FOR MULTIPLE UNITS

- Remove the connecting shaft (25).



- Remove the bearing carrier (24), diverter plate (16) or thrust plate, bearings (15), and ring seals (14), using procedure described previously for disassembly.

Port End Cover

- Use a knife blade or thin-blade screwdriver to gently pry the diverter plate (16) or the thrust plate off the bearings (15) of the port end cover (20).

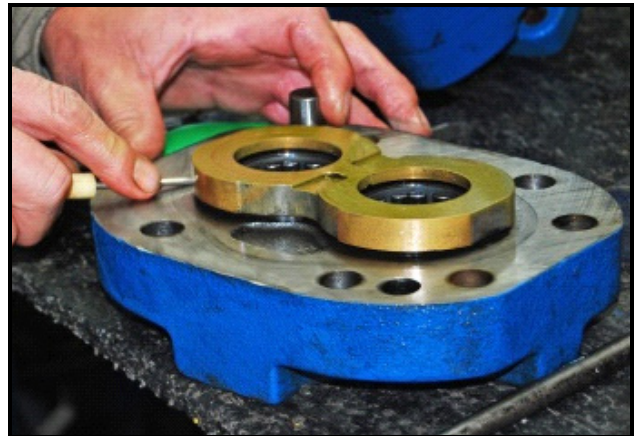

- When working on pumps other than PERMCO Pumps, remove and discard the pocket seals. When installing PERMCO diverter plates, you do not install replacement pocket seals; PERMCO diverter plates do not require pocket seals.
- If you plan to replace the two shaft roller bearings (15) with new ones, pull the bearings (15) out of the port end cover (20) with a bearing puller.
- Examine the ring seal (14). If worn, replace by pulling the drive gear bearing (15) out, leaving the driven gear bearing (15) in place.

SECTION 5

Water Pumps

5. Examine all diverter or thrust plates. Some wear will always appear because of gear flexing. Figure I indicates very slight wear, with some scratches because of contamination.



Figure J shows wear in the trapping area caused by contamination.

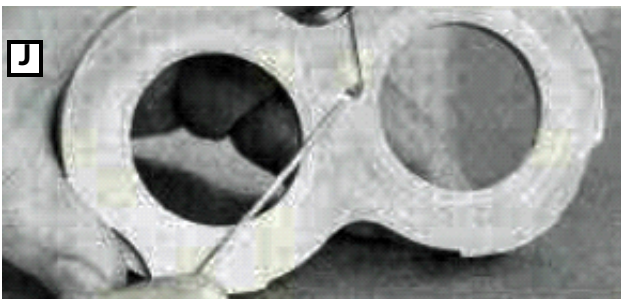

In bi-rotational units where there are two trapping grooves, a diagonal groove may develop, connecting the two slots. This is caused by contamination.

Figure K shows the effect of cavitation—defined as the rapid formation and collapse of vapor cavities within a fluid.



This effect is caused by high-vacuum inlet conditions or by air entering the pump inlet.

Reassembly

Shaft End Cover (7500 Series)

1. Grip shaft end cover (7) gear end up. Place ring seal (14) in the bearing bore of the shaft end cover (7) with flat side down.

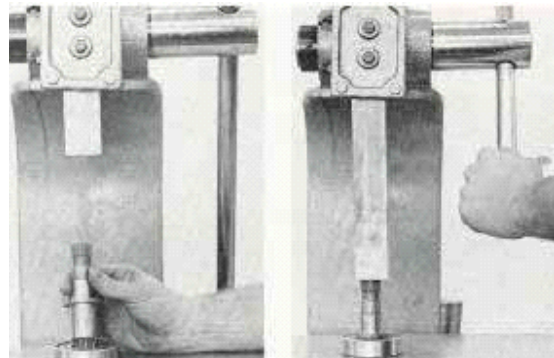

2. Replace the two roller bearings (15) in the bores of the shaft end cover (7). Take care that the drive bearing (15) does not cock or wedge between the ring seal and bottom of bearing counter-bore.

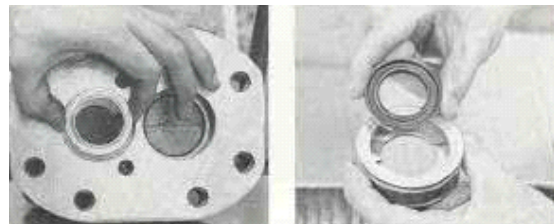

3. Place shaft end cover (7) in a soft jaw vise. Turn cover end-over-end and clamp with flange end up.

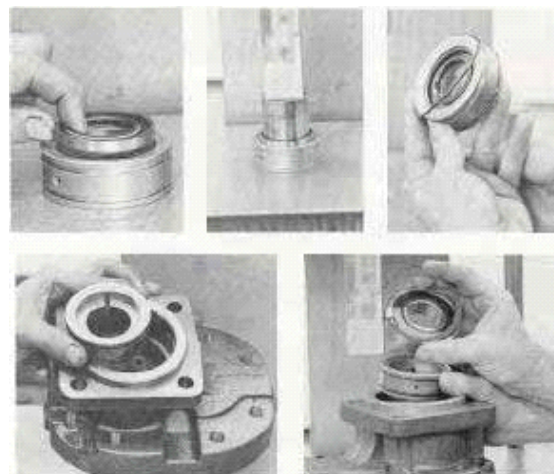

SECTION 5

Water Pumps

- Apply Loctite Adhesive Sealant No. 271 to outside of seal (3 or 6). Press seal into seal retainer (5) metal side down. Be careful not to damage seal. Install O-ring (27) on outside of seal retainer (5).

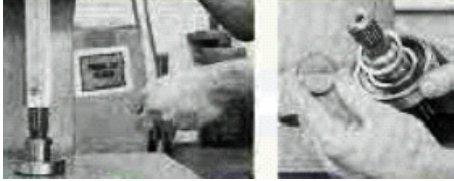

- Push this assembly into shaft end cover (7) with seal on inboard side. You can install bearing or bearing spacer and snap ring now, or at the end of assembly.

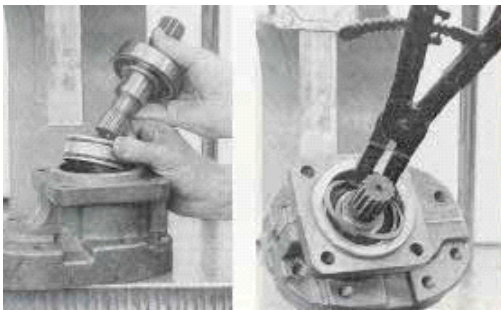

- Lubricate the drive shaft (9) and put this assembly into the shaft end cover (7). Be careful not to damage the seal.



- Install the snap ring (1) in the groove. The shaft end cover reassembly is now complete.

Port End Cover

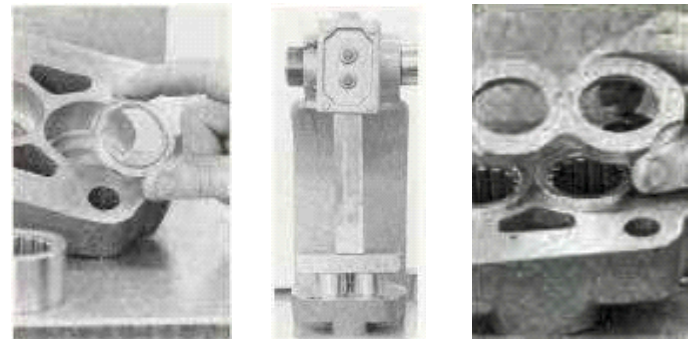

FOR CONTINENTAL SHAFTS

For type I pumps with "C" Type shafts, follow the above steps 1-4, and then proceed as follows:

- Push seal assembly into shaft end cover (7) with seal on inboard side.
- Press the outboard bearing (2) on the drive shaft (9) from the gear end.
- Push spacer (10) over the end of the shaft (9). Install snap ring (11) in the groove on shaft (9).
- Press the bearing (2) and spacer (10) tightly against the snap ring (11).

- If the two roller bearings (15) or the ring seal (14) were removed during disassembly, install new bearings (15) and ring seal (14) in the port end cover (20). Place the ring flat side down in the drive gear bearing bore, and make a medium press fit.
- Place the diverter plate (16) over the two roller bearings (15). The counter-bored side of the diverter plate (16) should be placed over the bearings (15) with the high-pressure crescent recesses toward the pump inlet side. Double-check the placement of the diverter plate (16) for correct positioning.

SECTION 5

Water Pumps

Bearing Carrier

1. If the four roller bearings (15) or ring seals (14) were removed during disassembly, install new bearings (15) and ring seals (14) in the bearing carrier (24). Place the ring seals (14) flat side down in the drive gear bearing bore and press bearing with a medium press fit.

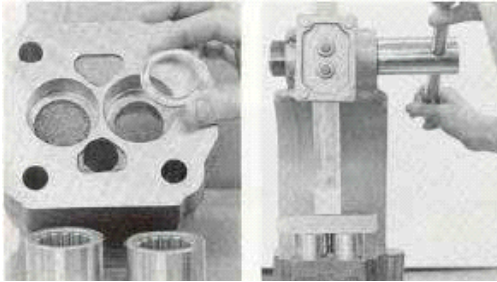

2. Place the diverter plate (16) over the two roller bearings (15). The counter-bored side of the diverter plate (16) should be placed over the bearings (15) with the high-pressure crescent recesses on the pump inlet side. Double-check the placement of the diverter plate (16) for correct positioning.



Final Reassembly

1. Clamp the shaft end cover (7) assembly in a soft jaw vise, gear end up.
2. Place the diverter plate (16) over the two roller bearings (15). The counter-bored side of the diverter plate (16) should be placed over the bearings (15) with the high-pressure crescent recesses on the pump inlet side. Double-check the placement of the diverter plate (16) for correct positioning.



3. Pour a little hydraulic, "STP", or a compatible fluid over face of diverter plate (16) to lubricate gears immediately on start-up. Gently stone the sides of each gear (119 and 26) to remove any burrs. Dip entire gear into cleaning solvent to remove all dirt and metal dust. Install drive gear first, then the driven gear. Be sure both gears are firmly in contact with diverter plate.



4. Lightly grease square gasket seals (17) and carefully install them in the grooves in the two faces of the gear housing (18). Be sure that they are fully seated.

SECTION 5 Water Pumps

5. Carefully place the gear housing subassembly over the gears, on top of the shaft end cover (7). Make sure the square gasket (17) is not pinched or cocked, and then tap the gear housing (18) down on the shaft end cover (7) with a soft mallet. Pour a little fluid over the gears while rotating the drive shaft. This will provide immediate lubrication when starting up pump. (If the unit is a **single** one, skip Step 6 and go to Step 7).

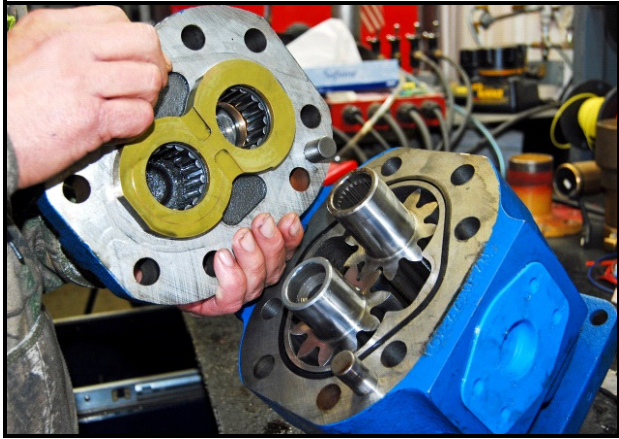

6. Position the assembled bearing carrier over the gear journals and gently tap it into place. Be sure the high-pressure crescents of the diverter plate (16) are positioned towards the pump low-pressure side. Install the connecting shaft (25).

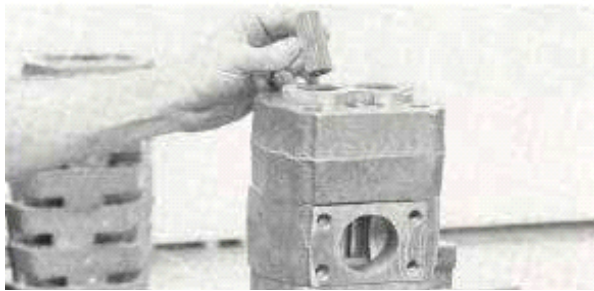

Repeat Steps 3 – 6 above until the final gear housing (18) is attached. Then pick up at Step 7 (next).

7. Place the port end cover (20) over the gear hubs (19) and place in gear housing (18) face-down. The drive gear has longer bearing hubs to engage the ring seal. Tap the port end cover (20) assembly gently down on the housing (18) with a soft mallet. Be sure the square gasket (17) is not pinched or cocked.



8. Put flat washers (21) over cap screws (22), or use Grade 8 threaded rod. Place screws or threaded rod in holes in port end cover (20).



Tighten evenly and alternately with a torque wrench to recommended torque shown in the table below.

Series	Size	No. Req.	Torque Lb.ft.
3000/5000	5/8-11 UNC-2A Thread	4	200
75000	5/8-11 UNC-2A Thread	8	200

Note: All bolts or tie rods must be SAE Class 8, with 150,000 PSI minimum tensile strength.



SECTION 5

Water Pumps

9. Test the assembled pump for free rotation by turning drive shaft by hand, using a wrench for leverage.

NOTE

Wrap several layers of cloth around shaft ends before applying wrench. The shaft should turn with slight effort, NO hard spots and NO rubbing noises.

If pump or motor is a 3000/5000 or a 7500 "C" series, it is ready to be put back in service. But if it is a **standard** 7500 series unit and the bearing and snap ring were not installed earlier, proceed to the following steps before putting it in service:

10. Release the unit from the vise and turn end-over-end so that the shaft end is facing up. Re-clamp unit in vise.

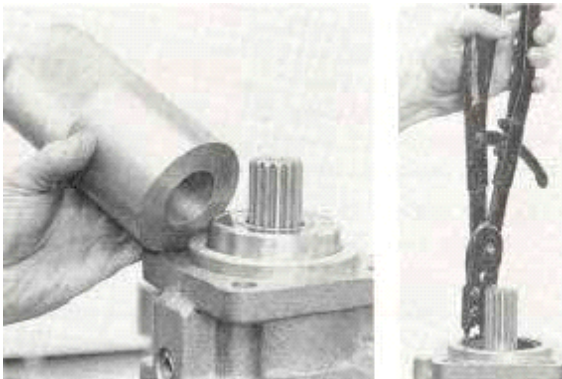

11. Install bearing (2) or bearing spacer (4). This is a slip fit over the shaft (9) and into shaft end cover (7).
12. Install the snap ring (11) into groove. Your **standard** 7500 series unit is now ready to put back in service.

Start-up Instructions For Permco Pumps

CAUTION

Ensure these directions are followed carefully. If the relief pressure setting is too high, the pump will be damaged.

1. Before operating the pump, unscrew the main relief valve adjusting screw on the main hydraulic system, **OR** remove adjusting shims or spacers.

2. Run the pump about 5 minutes under
3. **ZERO PRESSURE** with all control valves in neutral position. If the test system has a throttling valve, set it at 100 PSI above user's expected operating pressure.
4. If everything seems to function properly and no unusual noises are heard, back-off the throttling valve to zero. Shut down the system.
5. Adjust the relief valve pressure to the setting your hydraulic system requires.

Lubrication Of Permco Pumps

CAUTION

The hydraulic oil used in the entire circuit provides the lubrication for all parts of the pump. **Keep this oil clean and free of dirt.** A 25-micron return filter and a 149-micron (100-mesh screen) suction filter are recommended to fully protect the pump and system from excessive wear and damage from dirt.

1. If the pump fails and metal particles have gotten into the circuit:
 - a. Drain **ALL** oil from the entire system,
 - b. Flush the system with kerosene,
 - c. Refill the system with fresh oil of correct grade (These are correct oils:
Viscosity index at 100°F (37°C): 90 or higher;
Viscosity SUS at 100°F (37°C): 150 to 300 (32-65 CST);
Aniline point: 165 or higher;
Anti-foam and anti-oxidant additives.)
2. Temperature of oil should never exceed 185°F (85°C).
3. **NEVER** use low-viscosity naphtha-base oils, aircraft hydraulic fluids, or automotive brake fluids without first consulting MEGA Product Support.
4. For extended operation at temperatures below 20°F (-7°C), always use a low-pour-point oil of top quality.

SECTION 5

Water Pumps

HYDRAULIC DRIVE MOTOR SPEED CONTROL (CROSSOVER ASSEMBLY)

The hydraulic drive motor speed control (crossover assembly) consists of a flow control valve, 2 hydraulic manifolds, crossover hose and test ports.

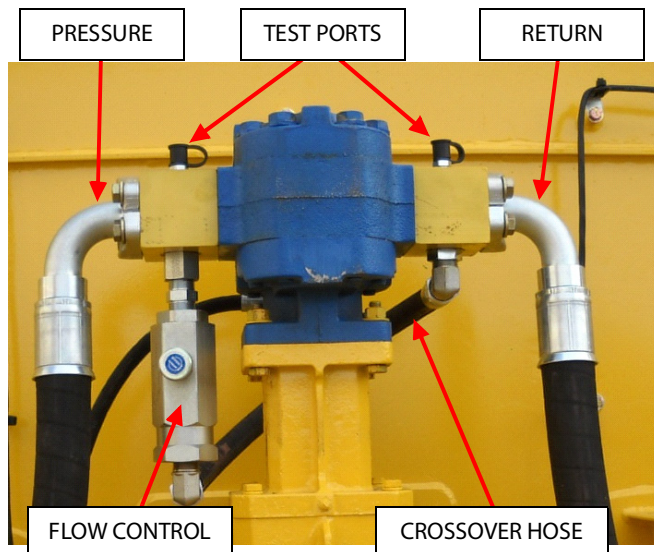

Hydraulic Flow Control Valve

The hydraulic flow control is directional. The arrow on the body indicates the direction of oil flow to meter the bypassing oil. The adjusting knob on the valve allows adjustment of the oil flow to bypass the drive motor, up to 135 LPM (35 GPM) or up to 700 RPM (RPM increase/decrease will vary depending on the size of hydraulic drive motor the unit is equipped with).

If the flow control is reversed, the flow control adjusting knob will not function and the full flow capacity of the valve will bypass. This can result in water pump rpm being below specifications with no adjustment capability of the adjusting knob. By turning the adjusting knob clockwise, the hydraulic oil that is bypassing will be reduced, increasing the speed of the water pump.

Turning the knob counter-clockwise will increase the volume oil being bypassed reducing the water pump speed. The flow control valve is typically mounted on the PRESSURE manifold of the hydraulic drive motor.

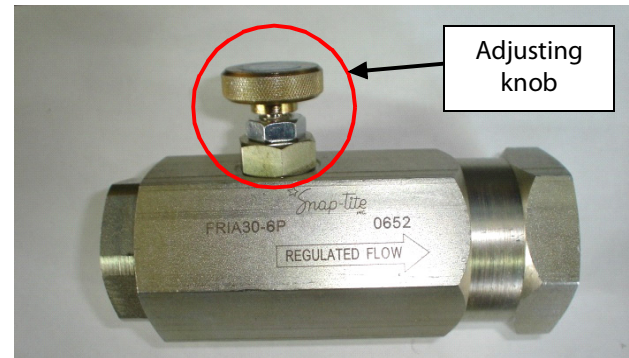

Typical 135 lpm (35 gpm) adjustable hydraulic flow control

HYDRAULIC DRIVE MOTOR ACTIVATION

The hydraulic drive motors are typically driven by the chassis hoist hydraulic system. The activation can be controlled by the following;

Existing Electric Hoist Valve

The MEGA cab control pump switch commands the hoist valve to operate by sending an electric signal to the electric solenoid on the hoist valve. This operates the hoist valve, diverting the hydraulic oil to the water pump drive motor.

Pilot Operated Diversion Valve

A remote mounted diversion valve that receives an electric signal from the cab control pump switch to activate a pilot control to move a spool within the diversion valve redirecting the hydraulic oil to flow to the water pump drive motor. Typically this type of valve is installed between the hoist pump and the hoist valve.

Existing Mechanically Operated Hoist Valve

Typically used on early model trucks with a pneumatic system. This system is operated by the cab control pump switch sending an electric signal to an electric/pneumatic solenoid to control a pneumatic cylinder. When the pneumatic cylinder operates it moves the spool valve of the hoist valve to divert hydraulic oil to the water pump drive motor.

SECTION 5

Water Pumps

WATER PUMP CAUTIONS

CAUTION

The water pump must only be turned ON or OFF at LOW idle only. Turning the water pump ON or OFF above LOW idle will result in shortened service life, damage and probable failure of the water pump.

CAUTION

Engaging/Disengaging the water pump above LOW IDLE may result in water pump component damage and reduced service life.

CAUTION

Do not operate the water pump in a dry sump. Dry running operation will cause water pump failure.

CAUTION

Limit water pump operation to 2.5 minutes when in a no-flow condition (not flowing water through spray heads, dump bar, monitor, drain valve or hose reel). Water pump operation in a no flow condition will cause overheating of the water pump and damage to the shaft seals and bearings.

CAUTION

Do not use the water pump switch to activate or deactivate the spray heads. Using the pump switch to cycle the spray heads ON and OFF will create shock loading on the hydraulic drive motor and the water pump due to the sudden stoppage of the hydraulic motor and will result in damage to the water pump shaft, impeller and hydraulic drive motor.

CAUTION

Lubrication of the M-3 and M-4 water pumps must be done using a **manual** grease gun only. If an auto-lube device, power grease gun or remote lubrication hoses are used, over or under lubrication may result, causing severe bearing, shaft and seal damage or failure.

CAUTION

Water pump RPM must not exceed the specifications listed below with engine at HIGH IDLE. Failure to ensure water pump speed is at or below specifications will result in reduced spray system component service life.

PUMP MODEL	RPM
M3 PUMP	2350 ± 50
M4 PUMP	1900 ± 50
B4 PUMP	1,950 ± 50
M4B PUMP	1,950 ± 50

If water pump RPM is to out of the desired range, adjust the water pump hydraulic drive motor flow control valve to obtain specified RPM.

CAUTION

Avoid any sudden stoppage of water pump e.g; disengaging water pump above LOW IDLE. Stopping water pump suddenly above LOW IDLE will result in shaft, impeller and drive motor damage.

SECTION 5 Water Pumps

WATER PUMP IDENTIFICATION

M-3

The M-3 pump is the smallest of all four water pumps, and is easy to identify by the following references:

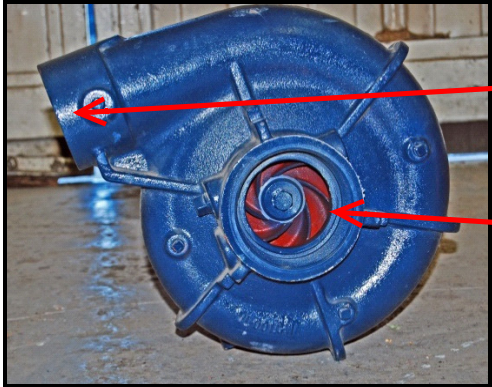

3 inch NPT outlet

4 inch NPT inlet

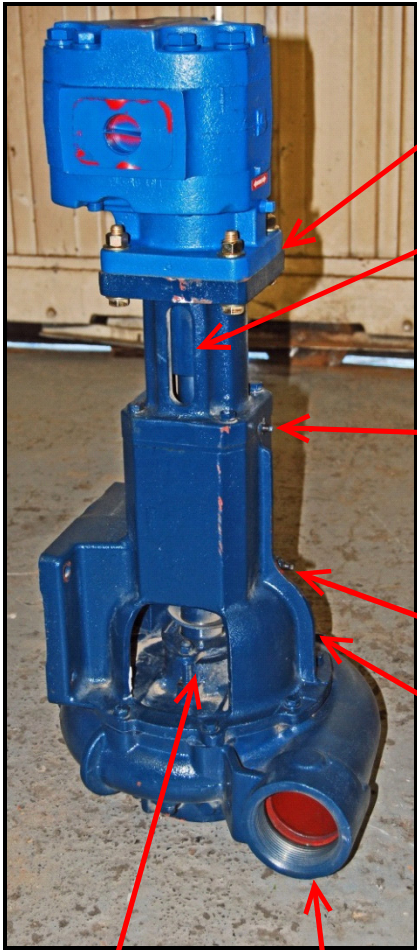

Square 4 bolt motor flange

Access slots on motor mount

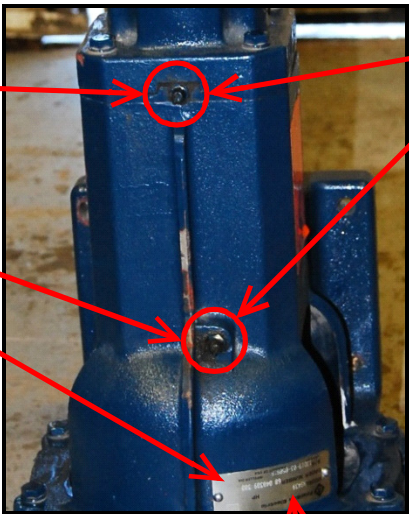

Grease fittings, 2 each

Rope pack- ing seal

3 inch NPT inlet

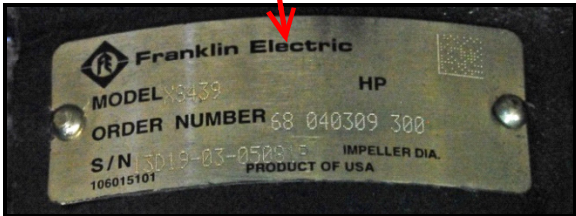

SECTION 5

Water Pumps

SIDE-BY-SIDE COMPARISON OF M-4 AND M-4B

The M-4 and M-4B pumps are difficult to distinguish between as they are very similar in appearance. The following side-by-side comparison will assist in differentiating the M-4 and M-4B pumps by pointing out specific areas in which they differ.

1. **Motor Mount Flange**
 - a. M-4 Motor mount flange is square and is the same size as the motor flange
 - b. M-4B Motor mount flange is oval in shape with 2 parallel flats and is larger than the motor flange
2. **Motor Mount**
 - a. M-4 Motor mount has access openings for tightening the drive coupling set screws
 - b. M-4B Motor mount is enclosed, no opening
3. **Lifting Lugs**
 - a. M-4 Lifting lugs are on the pump frame
 - b. M-4B Lifting lugs are on the motor mount
4. **Pump Frame**
 - a. M-4 pump frame is **larger** than the M-4B frame
5. **Strengthening ribs on pump frame**
 - a. M-4 has **no** ribs on pump frame
 - b. M-4B has ribs on pump frame
6. **Volute Case Ribs**
 - a. M-4 has **no** ribs on volute case
 - b. M-4B has ribs on volute case

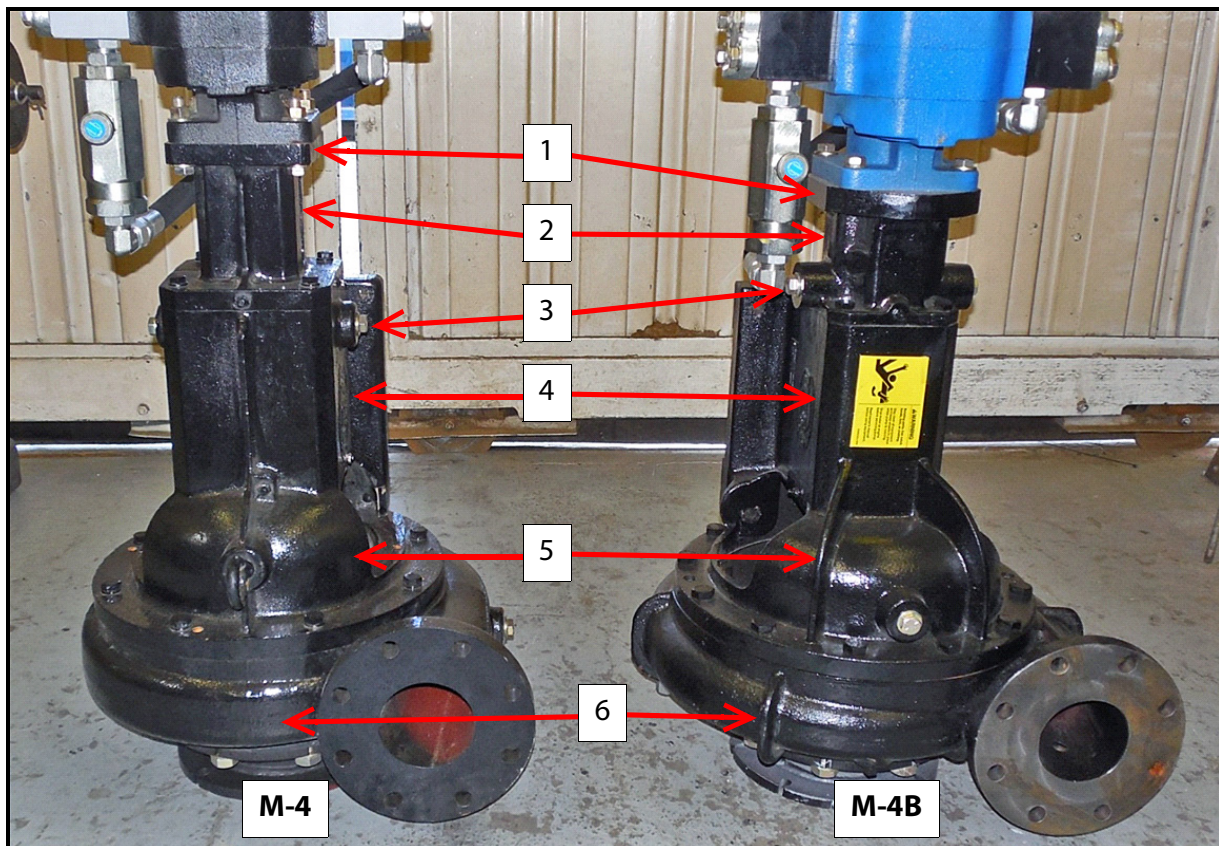

- | | |
|------------------------|----------------------------------|
| (1) Motor mount flange | (4) Pump frame size |
| (2) Motor mount | (5) Presence of pump mount ribs |
| (3) Lifting lugs | (6) Presence of volute case ribs |

SECTION 5 Water Pumps

7. Seal Opening Size

- a. M-4 has a **smaller** seal opening than the M-4B

8. Packing Mount Ribs

- a. M-4 has **no ribs** on packing mount
- b. M-4B **has ribs** on packing mount

9. Volute Case Bolt Size

- a. M-4 has **smaller** volute case bolts than the M-4B

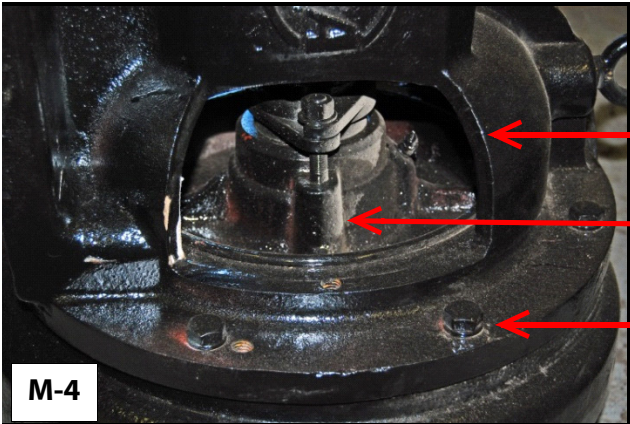

M-4

- (7) Smaller seal opening
- (8) No ribs on packing mount
- (9) Small volute case bolts

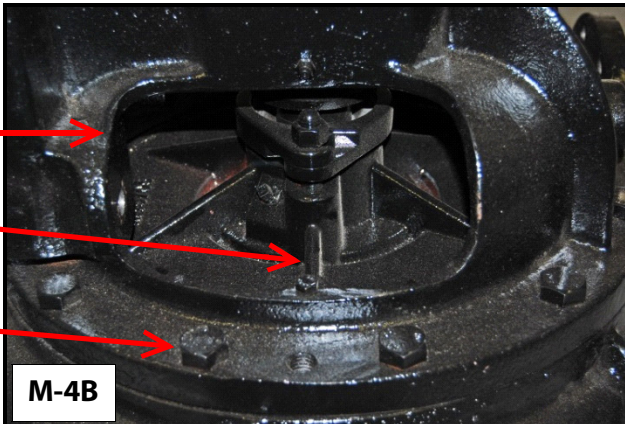

M-4B

- (7) Large seal opening
- (8) Ribs on packing mount
- (9) Large volute case bolts

10. Motor Mount Bolts

- a. M-4 motor mount bolts **require** nuts
- b. M-4B has a threaded motor mount; bolts do **not require** nuts

11. Motor Mount Flange Shape

- a. M-4 motor mount flange is **square-shaped**
- b. M-4B motor mount flange is **oval-shaped**

12. Open/Closed Motor Mount

- a. M-4 has an **open** motor mount for coupler set screw access
- b. M-4B has a **closed** motor mount (no opening)

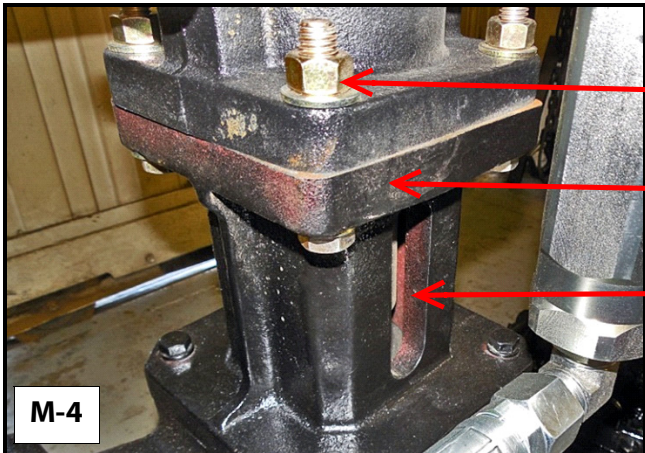

M-4

- (10) Motor through bolts with nuts
- (11) Square motor mounting flange
- (12) Open motor mount for coupler set screw access

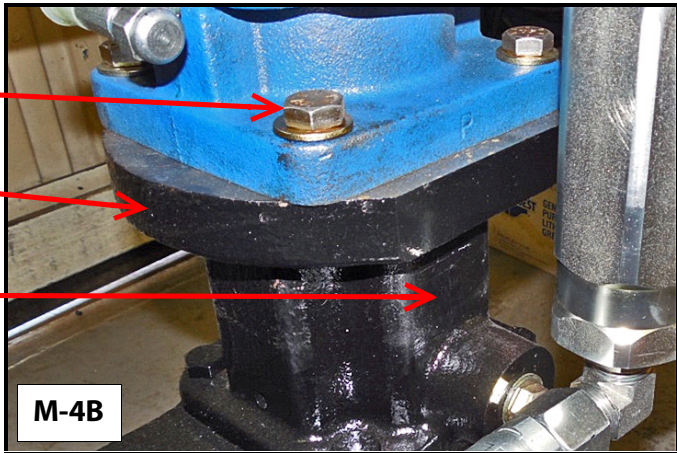

M-4B

- (10) Threaded motor mount, no nuts
- (11) Oval-shaped motor mount flange
- (12) No opening in motor mount

SECTION 5 Water Pumps

13. Lifting Lug Location

- a. M-4 lifting lug is located on the pump frame.
- b. M-4B lifting lug is located on the motor mount.

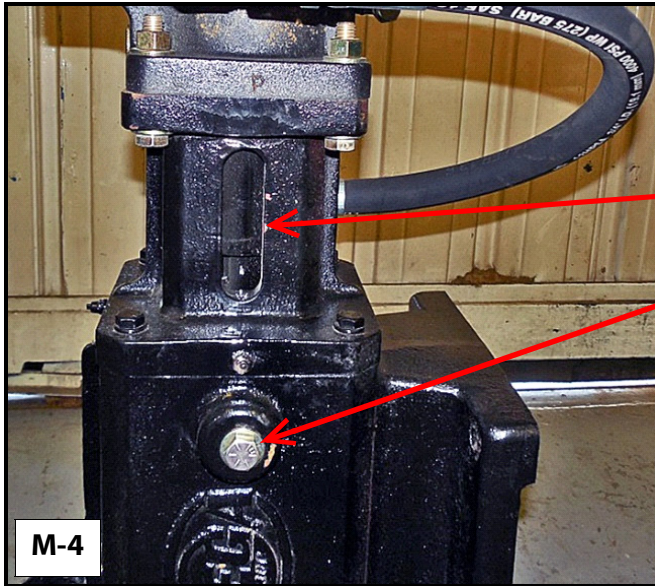

(12) Open motor mount for coupler set screw access
(13) Square motor mounting flange

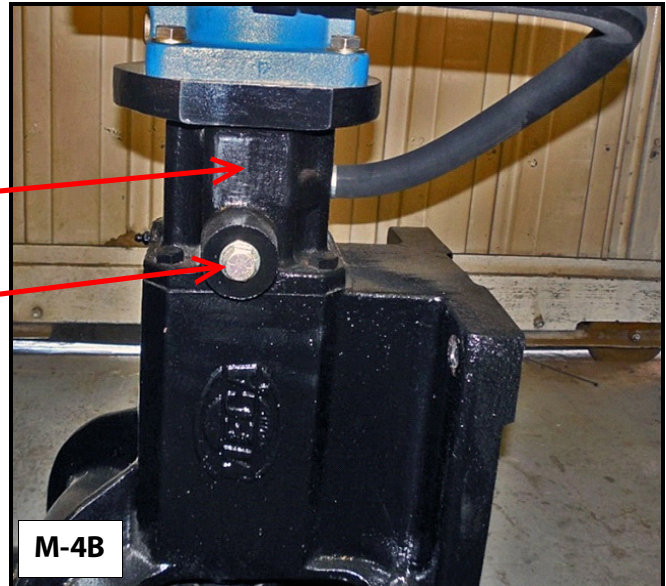

(12) No opening in motor mount
(13) Oval-shaped motor mount flange

14. Grease Fitting Locations: Grease fittings are located in different places on the M-4 and M-4B. Note that in the images below, the M-4 and M-4B pumps are at different angles. Additionally, the M-4 has a lantern ring grease fitting, whereas the M-4B does **not** have a lantern ring and therefore has no grease fitting for one.

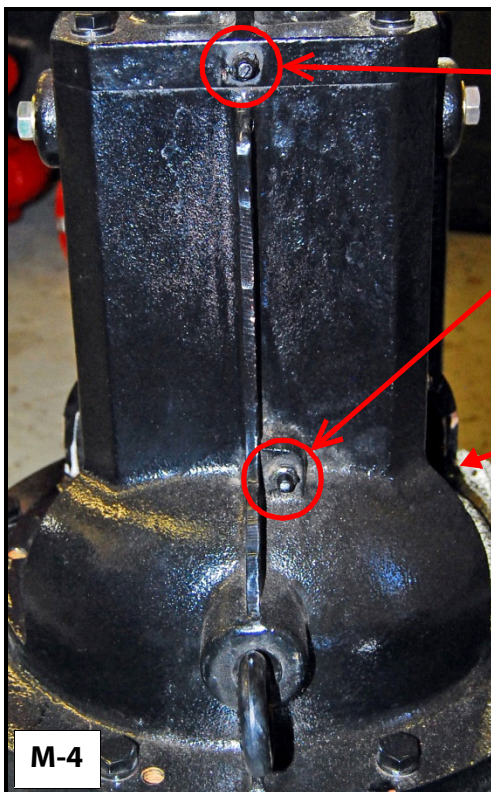

Drive end bearing
grease fitting

Impeller end bearing
grease fitting

Lantern ring grease
fitting (M-4 only)

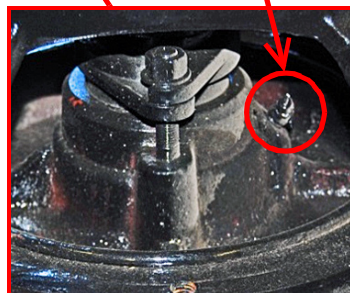

SECTION 5 Water Pumps

15. Grease Cavity Vent Locations: Grease cavity vents (also known as ‘turkey timers’) are located in different places on the M-4 and M-4B. Additionally, the M-4 has **two** grease cavity vents, whereas the M-4B has only **one**. Note that in the images below, the M-4 and M-4B pumps are at different angles.

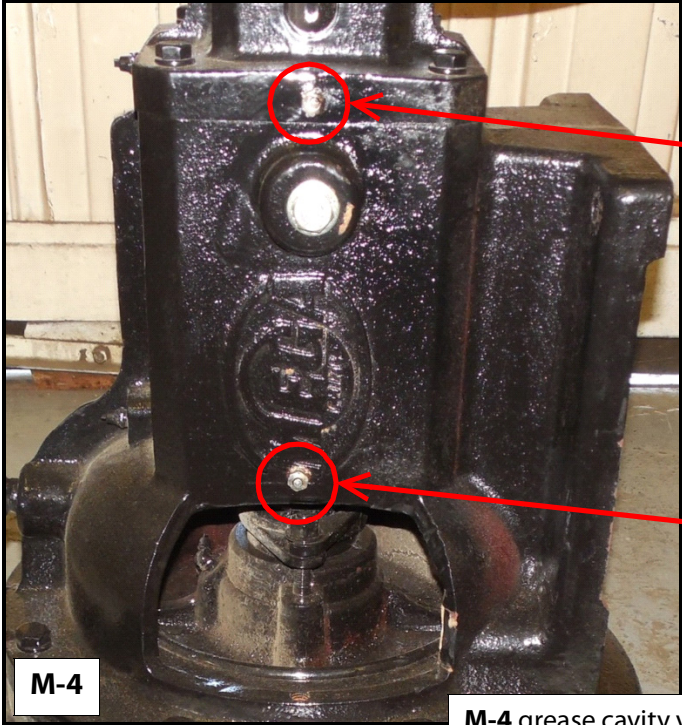

M-4

M-4 grease cavity vents (turkey timers):
located on motor mount and pump frame

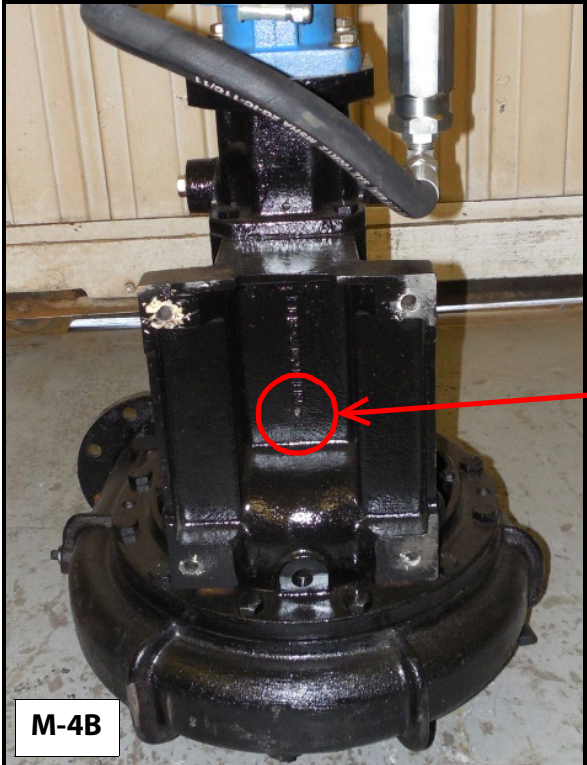
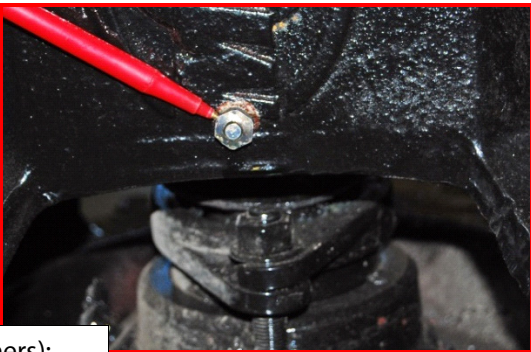
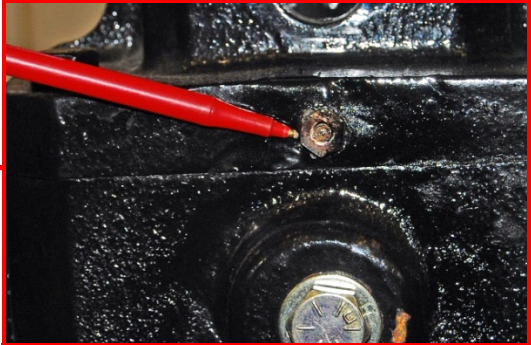

M-4B

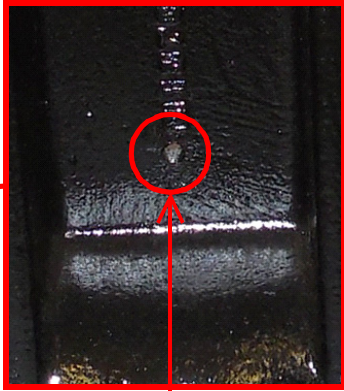

M-4B grease cavity vent:
located on the pump frame

SECTION 5 Water Pumps

16. **Water Pump Data Tag Location:** The water pump data tags are located in the same place on both pumps, but contain different information. The M-4 data tag has the serial number and Mega part number only. The M-4B data tag has the pump model, serial number, impeller diameter (in inches), and Berkeley model number.

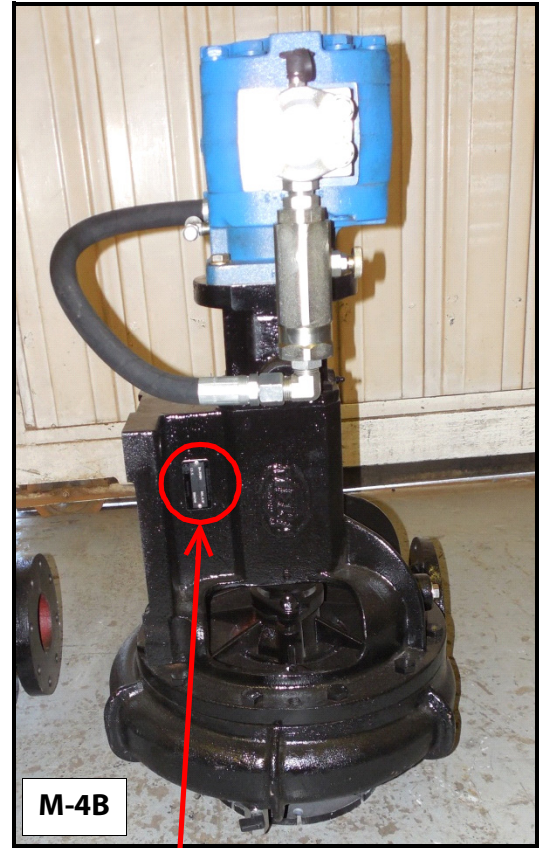

SECTION 5 Water Pumps

Hydraulic Drive Motor Couplings

The Franklin-made pumps (M-3 and M-4) have different input shafts than the Berkeley-made pumps (B-4, M-4B). M-3 and M-4 water pumps have a keyed input shaft, whereas B-4 and M-4B water pumps have a spline input shaft. The following information is provided to help differentiate between the drive motor couplings for the M-3/M-4 and the M-4/M-4B.

M-4 and M-3 drive Coupling:

The M-4 and M-3 drive coupling is keyed at the water pump shaft, secured by set screws, and is splined at the drive motor end.

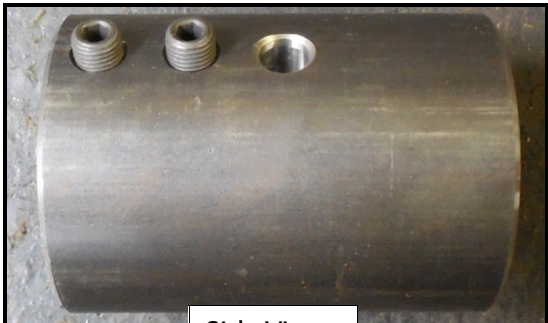
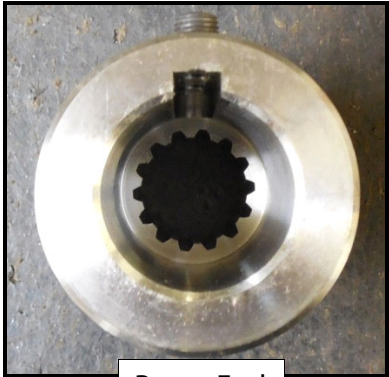

M-4B and B-4 Drive Coupling

M-4B and B-4 drive coupling is the same at both ends and is allowed to float on the shafts.



SECTION 5

Water Pumps

M3 WATER PUMP



Description

An open centrifugal type water pump mounted to the water tank supplies water pressure and flow for tank mounted spray heads, water cannon, dump bar, and hose reel. The water pump shaft is driven clockwise (CW) by a hydraulic motor mounted to the water pump bracket.

⚠ WARNING

Due to the nature of these processes, ensure that all safety information, warnings and instructions are read and understood before any operation or any maintenance procedures are performed. This service function takes place with heavy components and at moderate heights, ensure all proper safety procedures and equipment are maintained when performing this service. Failure to use and maintain proper safety equipment and procedures will cause personal injury, death or damage to equipment.

M3 Water Pump Major Components and Functions

1. BRACKET – Main frame of the pump that allows a pump to be bolted to the tanker and provides the means to direct mount the hydraulic drive motor.
2. VOLUTE CASE – A snail shell shaped case that encloses the impeller. It is narrow at the center and enlarges from there to the discharge area.
3. IMPELLER – Rotating wheel attached to the shaft that accelerates the speed of the water producing water flow and pressure.
4. DRIVE MOTOR MOUNT – Mount to secure hydraulic drive motor to bracket of pump and to protect drive coupling.
5. SHAFT SEAL SLEEVE – A replaceable polished steel sleeve that provides a smooth surface for rope seal to ride on.
6. ROPE SEAL – Provides a seal around the rotating pump shaft at the volute case. Constructed of a graphite rope material that is designed to drip water and allow shaft lubrication.
7. UPPER/LOWER BEARINGS - Provide roller surface for the pump shaft.

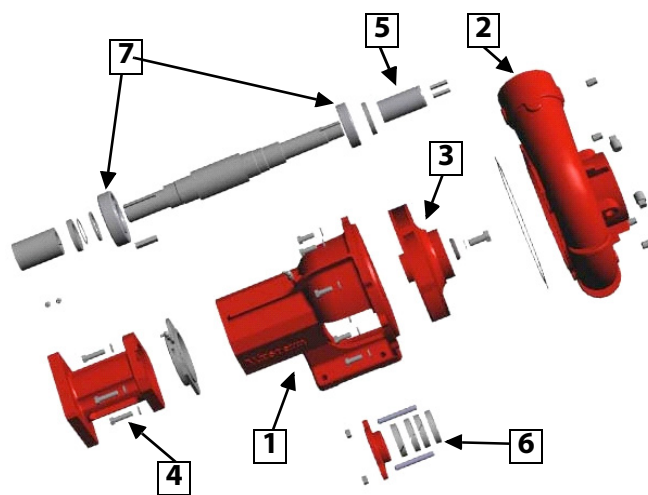

SECTION 5

Water Pumps

M3 WATER PUMP INSPECTIONS

WARNING

Due to the nature of these processes, ensure that all safety information, warnings and instructions are read and understood before any operation or any maintenance procedures are performed. This service function takes place with heavy components and at moderate heights, ensure all proper safety procedures and equipment are maintained when performing this service. Failure to use and maintain proper safety equipment and procedures will cause personal injury, death or damage to equipment.

CAUTION

- All of the scheduled inspections are essential for proper water pump service life and operation. Failure to perform scheduled water pump maintenance at the prescribed time or hour intervals (whichever comes first) will result in reduced service life, water pump damage or water pump failure.
- Ensure that the water pump is **manually** lubricated. Do not lubricate the water pump bearings with an Auto-Lube device, remote lube hosing, or a power grease gun. Over-lubrication can cause shaft and bearing overheating causing bearing or shaft failure. If water pump is lubricated by any other means, water pump or bearing failure will result.
- Over-tightening of the packing gland will cause premature failure of the rope packing seal and damage to the water pump shaft.
- The water pump must be removed from the unit to ensure a complete and comprehensive inspection is carried out properly. Failure to remove, inspect and repair internal components at the scheduled interval will result in water pump damage or failure.

NOTE

Check the discharge volume of the grease gun being used for this operation. Every grease gun has a different volume per stroke. 8 to 10 squirts (strokes or injections) corresponds to approximately 1 fl. oz. (30 cc) of grease.

Initial Operation And In-service Of M-3 Water Pump

Prior to the initial operation of the water pump, ensure the 2 shaft bearings are lubricated. The drive end bearing will receive 2 fl. oz (60 cc) of grease and the impeller end bearing will receive 2 fl. oz (60 cc) of grease.

CAUTION

- Measure the grease gun discharge to be used in this operation to ensure that the volume required is properly applied. Each grease gun will have a different volume per stroke and will need to be measured. If insufficient or excess grease is applied damage to water pump may result.
- Lubrication of the M-3 water pump must be done using a manual grease gun only. If an auto-lube device, power grease gun or remote lubrication hoses are used, over or under lubrication may result, causing severe bearing and seal damage or failure.

After initial system operation check and prior to in-service operation of water tanker, inspect and adjust the following:

1. Fill unit with sufficient water to perform dynamic system checks (above the level of the rear spray heads).
2. Adjust all of the spray head pattern adjustment rings to the widest opening.
3. Inspect water pump shaft seal for leaks, adjust rope packing glands as required.

SECTION 5 Water Pumps

- Operate spray system and check for proper system operation for no more than 2.5 minutes at high idle.

CAUTION

- Limit water pump operation to 2.5 minutes when in a no-flow condition (not flowing water through spray heads, dump bar, monitor, drain valve or hose reel). Water pump operation in a no flow condition will cause overheating of the water pump and damage to the shaft seals and bearings.
 - Operating the water pump with a dry sump will result in shaft seal damage.
 - Engaging or disengaging the water pump above LOW IDLE will result in water pump component damage and reduced service life.
- Return system to LOW IDLE and check for shaft seal leakage.
 - Shut water PUMP OFF.
 - Shut spray SYSTEM OFF and remove electrical and hydraulic power from unit.
 - If shaft rope packing leakage is more than the desired 1 drop per second, adjust shaft rope seal packing gland by tightening the retaining nuts evenly until the desired leakage rate is achieved.

CAUTION

This type of shaft rope packing seal is designed to leak a small amount of water. (2 drops per second at the minimum). Failure to allow some water leakage will cause premature rope packing failure and shaft sleeve damage. Over-tightening the packing gland will cause packing mount, packing gland, shaft, shaft sleeve and shaft rope packing seal damage.

- Adjust shaft seal packing gland as instructed to minimize water leakage.

NOTE

After water tanker has been in operation several hours, re-check shaft rope packing seal for leakage. Re-adjust as necessary, using caution not to over-tighten packing gland.

M3 ROUTINE MAINTENANCE AND REPAIR

Rope Seal Replacement

WARNING

Ensure machine is prepared for service and no potential hazards exist. Follow all proper safety procedures and use all required PPE when performing this service. Failure to ensure all safety procedures are followed and PPE is worn may result in serious personal injury or death.

NOTE

Rope packing replacement can be performed without removing the water pump from the water tanker. In the images below, the shaft has been removed for clarity.



SECTION 5

Water Pumps

1. Slide packing gland towards the pump bracket.



2. Remove old rope seals.

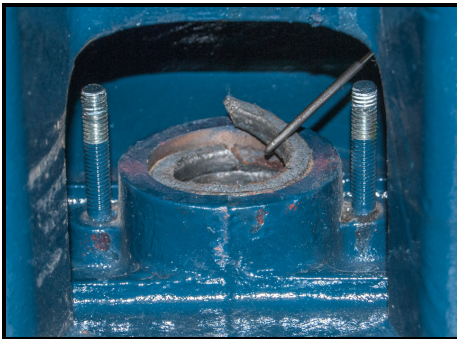

3. Install one rope seal at a time while indexing the seal gaps 180° from each other.
4. Install packing gland and snug the retaining nuts.
5. Follow the initial operation guidelines to adjust rope packing gland to achieve the minimum leakage rate of 2 drops per second.

CAUTION

Do not over-tighten packing gland. When installing new packing snug gland retaining nuts. If adjustment is necessary, evenly tighten retaining nut to slow water leakage. If gland nuts are over-tightened, shaft, packing, and gland damage will occur. This rope packing type seal is designed to weep water (about 2 drops per second).

Water Pump Removal

1. Ensure water tank is empty.
2. Remove all electrical/hydraulic power and make the vehicle safe for maintenance.
3. Remove hydraulic motor and associated hydraulic lines.

CAUTION

Ensure all open hydraulic lines are capped to prevent hydraulic system contamination.

NOTE

Some water pump installations allow the hydraulic motor to be detached without removing associated hydraulic lines.

4. Uncouple (e.g. victalic/dresser coupling) system piping from the discharge port of the volute case.

NOTE

In some applications, extensive disassembly may be necessary to remove water pump from unit. Observe and follow all safety procedures when performing this operation.

5. Remove water pump to tank sump mount bolts and remove water pump.

SECTION 5 Water Pumps

Water Pump Disassembly And Inspection

Impeller

Volute Case

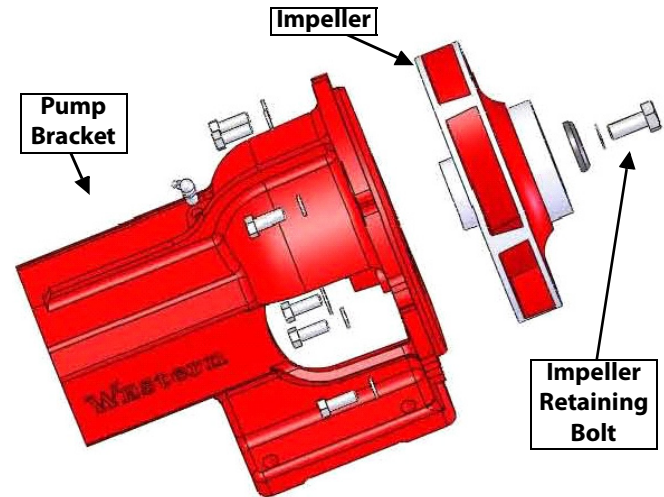
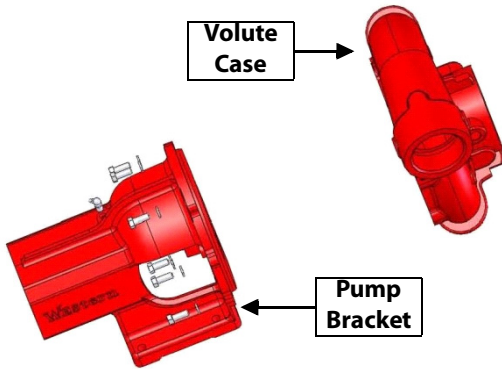

1. Remove volute case mounting bolts and separate volute case from pump bracket. Use the jack screw holes on the pump bracket to assist in separating the volute case from the pump bracket.

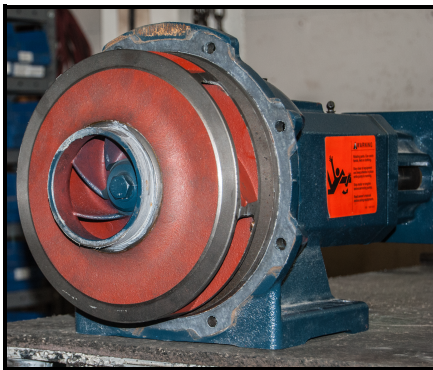

1. Remove impeller mounting bolt, impeller, and keys.



2. Inspect the volute case for the following:
 - a. Case for damage, cracks, and excessive pitting.
 - b. Impeller wear surfaces for wear and damage.
 - c. Contact wear from impeller inside of the volute case.

SECTION 5 Water Pumps

Hydraulic Motor Drive Coupling and Motor Mount

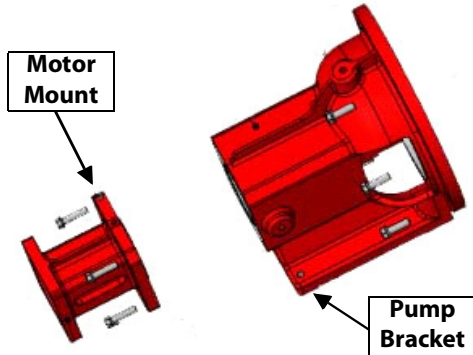

1. Remove set screws from hydraulic motor drive coupling.



2. Remove hydraulic motor drive coupling and mount bolts and separate mount from pump bracket.



3. Inspect grease seal for damage and condition.
4. Inspect hydraulic motor shaft for wear and damage.
5. Inspect hydraulic motor shaft seal for leaks.

6. Inspect hydraulic motor mount for cracks and damage.

Shaft & Bearing Assembly

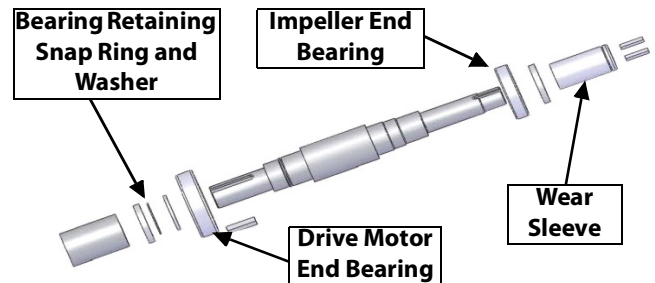

1. Remove shaft and bearing assembly from water pump bracket.



2. Thoroughly clean inside of pump frame to ensure no old grease remains in pump frame.

SECTION 5

Water Pumps

3. Disassemble shaft assembly as follows:
 - a. Remove shaft coupling by removing set screws and applying heat to the coupling.
 - b. Remove snap ring and thrust washer.
 - c. Remove upper bearing.
 - d. Apply heat to rope packing wear sleeve and remove.
 - e. Remove lower bearing.
 - f. Remove grease seal from pump frame.
4. Inspect shaft and bearing assembly as follows:
 - a. Shaft for damage, cracks and condition.
 - b. Upper and lower bearings for damage, excessive play and freedom of rotation.
 - c. Grease seal for damage and condition.
 - d. Wear sleeve for damage and condition.
5. Reassemble shaft assembly as follows:

CAUTION

Manually pack the shaft bearings with grease prior to installation. Failure to ensure adequate lubrication of the bearings will result in shortened service life, bearing, shaft and possible water pump damage or failure.

- a. Install lower bearing, thrust washer and snap ring.
- b. Install wear sleeve with LOCTITE®.



- c. Install upper bearing, thrust ring, and snap.
- d. Pack upper and lower bearings with grease.

Water Pump Reassembly

1. Remove all grease from the pump bracket bearing cavities.
2. Install grease seal in bracket assembly (lip side OUT).

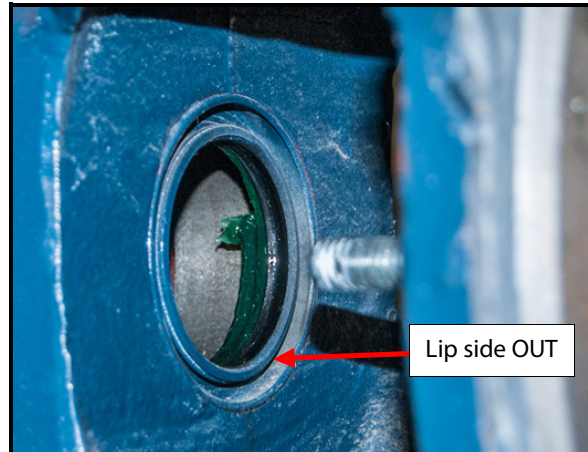

3. Ensure upper and lower bearings are packed with grease and install shaft and bearing assembly partially in the water pump bracket.

CAUTION

Use care when inserting the shaft into the pump bracket. Ensure the shaft does not damage the front seal when installing the shaft in the pump bracket. Failure to use caution when installing shaft and inspecting the seal for seal damage after the shaft is installed may result in shortened service life or pump, bearing and shaft damage.



4. Install rope packing.



SECTION 5 Water Pumps

5. Loosely install packing gland.



6. Install slinger on shaft.

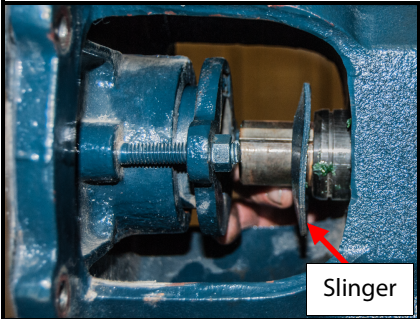

7. Fully seat shaft assembly in pump bracket.

8. Install drive motor mount with grease seal (lip side OUT). LOCTITE® and torque the mount bolts to 45 n-m (33 ft-lbs).

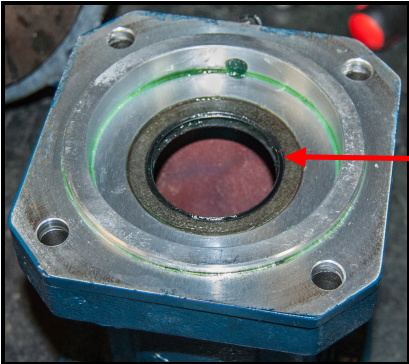

9. Install drive motor coupling with LOCTITE® and tighten set screws and torque the set screws to 12 ft-lbs (17 n-m).

SECTION 5

Water Pumps

10. Coat impeller inlet wear surface with anti-seize or equivalent lubricant.



11. Install shaft keys and impeller on lower end of the shaft.

12. Install, apply LOCTITE®, and torque impeller retaining bolt to 58 n-m (43 ft-lbs).



13. Coat Volute case gasket with light grease.



14. Position volute case gasket on pump bracket.

15. Install volute case and tighten 8 mount bolts. Torque Volute case bolts to 45 n-m (33 ft-lbs) in a criss cross pattern.

16. Lubricate water pump shaft bearings (2 each) with a manual grease gun to inject 2 fl oz. (60 cc) of grease in the drive motor end bearing and 2 fl oz (60 cc) of grease in the impeller end bearing while rotating the shaft.

Water Pump Installation

1. Remove material from mounting pipes. Inspect and replace coupling seals as required.
2. Locate water pump on inlet pipe with the required end couplings. Tighten inlet couplings and pump mount bolts.
3. Remove old couplings from water pipe. Inspect and replace coupling seals as required.
4. Install all components that were removed when removing water pump. Tighten hardware.
5. Ensure that the water pump has been lubricated with 2 fl. oz. (60 cc) in the drive motor end bearing and 2 fl oz (60 cc) in the impeller end bearing.

CAUTION

Failure to ensure the water pump shaft bearings are adequately and properly lubricated will result in shortened service life, bearing, shaft, and possible water pump damage or failure.

6. Inspect shaft coupling for damage and replace if required.
7. Install hydraulic drive motor and associated hosing. Tighten all mounting bolts.
8. Operate water pump system while checking for leaks as well as component operation.
9. Locate water pump to inlet pipe. Tighten inlet pipe coupling and pump mount bolts.

SECTION 5

Water Pumps

10. Install discharge pipe couplings and mount bolts. Tighten all mounting hardware.
11. Perform water pump functional check and rpm adjustment procedures.

M3 FUNCTIONAL CHECK AND RPM ADJUSTMENT

These procedures are designed to perform dynamic checks of the water pump system and perform RPM adjustments if required. This process also provides information in troubleshooting water pump systems. Ensure that water pump RPMs, hydraulic pressures and water pressure is documented and returned to MEGA Corp with the in-service report.

⚠ WARNING

Ensure MAC and truck is configured for water truck application before proceeding with this test. Failure to ensure proper configuration may result in damage to chassis and tank.

1. Install hydraulic test gauges on the hydraulic motor quick disconnect test ports.
2. Install water pressure gauge on the spray bar assembly ball or gate valve.
3. Fill water tank with a sufficient amount of water to perform water pump RPM adjustment and functional check of all water spray systems to include the water cannon (if equipped).

CAUTION

Do not operate the water pump in a dry sump. Dry operation will result in shaft seal damage.

4. Once tank is full, check pump couplings for static leaks.
5. Adjust all spray head adjustment rings to full flow and maximum pattern width to allow free flow of metal contaminants during testing.
6. Ensure all cab control switches are in the OFF position.

Electrical Power On And Engine Off

7. Ensure vehicle battery power is connected.
8. Ensure all cab control switches are in the OFF position.
9. Turn vehicle key switch ON (engine off). Ensure the vehicle cycles through recommended ECM functions per chassis specific Operators Manual and all warning and advisory lights extinguish.

Electrical Power On And Engine On

10. Ensure the area around the vehicle is well clear and ample space is available to operate spray heads and water cannon.

CAUTION

Use caution when performing this test. Water may be discharged from any of the available openings when performing this test function.

11. Ensure wheels are chocked, parking brake is set and vehicle is safe to operate.
12. Ensure all spray heads, dump bar, drain valve, water cannon and foam switches are in the OFF position.
13. Start up the vehicle and ensure all required warning and advisory lights extinguish per chassis specific Operators Manual.
14. While the vehicle is running inspect all installed water pump hydraulic components and hoses for leaks.
15. Turn the cab control box SYSTEM/POWER switch ON.

SECTION 5

Water Pumps

16. Turn the cab control box PUMP switch ON. Inspect all water pump and associated water components (torque tube manifold, water pump hydraulic drive motor and cross-over) connections and hoses for leaks.

CAUTION

Do not engage/disengage the water pump above LOW IDLE. Engaging/disengaging the water pump above low idle will result in water pump component damage and reduced service life.

17. Ensure water pump shaft is rotating in a CW direction.

18. Inspect vehicle hydraulic tank to ensure sufficient fluid level is available for continuing test. If sufficient fluid is not available shutdown vehicle, service hydraulic tank and restart vehicle.

CAUTION

Ensure that the tank is filled with sufficient water to perform operational test. Maximum capacity is recommended. Operating the water pump in a dry sump will result in shaft seal damage.

19. Increase engine RPM to normal operating range and check all installed water pump components and hoses for leaks.

20. Note hydraulic pressure and return readings as well as water pump pressure at about 2,100 engine RPM on work sheet provide in the rear of this tech manual.

21. Reduce engine speed to LOW IDLE.

22. Turn water PUMP OFF.

CAUTION

Do not engage/disengage the water pump above LOW IDLE. Engaging/disengaging the water pump above low idle will result in water pump component damage and reduced service life.

23. Turn SYSTEM/POWER OFF.

24. Shutdown vehicle.

M3 WATER PUMP RPM ADJUSTMENT

1. Clean water pump shaft and install reflective tape just above the packing gland.

2. Install a photo tachometer to measure water pump shaft speed or prepare hand-held device.

3. Adapt a water pressure gauge to the rear spray bar ball or gate valve.

4. Ensure all spray system switches are in the OFF position.

5. Start up vehicle.

6. At LOW IDLE turn the cab control SYSTEM/POWER switch ON, then the PUMP switch ON.

CAUTION

Ensure the MAC is filled with sufficient water to perform operational test. Do not operate the water pump in a dry sump. Dry operation will result in shaft seal damage.

7. Ensure the water pump is turning in a CW rotation. Note water pump RPM and spray bar water pressure.

⚠ WARNING

Do not place your hand or tools within pump bracket while pump is rotating and/or pressure held within the motor supply hose. Failure to follow proper safety procedures could result in serious injury.

SECTION 5

Water Pumps

- 8. Operate vehicle at HIGH IDLE. Note water pump speed and water pressure. Water pump speed should range from 2,300 to 2,400 RPM and spray bar pressure should range from 483-620 kpa (70-90 PSI).

CAUTION

Water pump RPM must not exceed 2,400 rpm with engine at high idle. Failure to keep water pump speed below 2,400 RPMs will result in water pump failure.

- 9. If water pump RPM is to out of the desired range, adjust the water pump hydraulic drive motor flow control valve to obtain specified RPM.

CAUTION

Do not operate water pump at HIGH idle for longer than 2.5 minutes without discharging water from spray heads or monitor. Allowing the water pump to run longer than 2.5 minutes may cause water pump to overheat resulting in damage to the water pump, seals and bearings.

NOTE

The flow control valve can control as much as 15 GPM (57 lpm) or about 600 RPM.

- 10. Once desired RPM is obtained, tighten jam nut on flow control valve.
- 11. Reduce engine speed to LOW IDLE.
- 12. Turn water PUMP OFF.
- 13. Turn SYSTEM/POWER OFF.
- 14. Shut down vehicle.
- 15. Remove photo tachometer and water and hydraulic pressure gauges.

M3 WATER PUMP IN-SERVICE NOTES

With Engine at LOW IDLE Note the following:

WATER PUMP DRIVE MOTOR PRESSURE:

_____ PSI

WATER PUMP DRIVE MOTOR RETURN PRESSURE:

_____ PSI

With Engine at HIGH IDLE Note the following:

WATER PUMP DRIVE MOTOR PRESSURE:

_____ PSI

WATER PUMP DRIVE MOTOR RETURN PRESSURE:

_____ PSI

WATER PUMP SHAFT RPM:

_____ RPM

CAUTION

M-3 Water pump RPM must not exceed 2,400 rpm with engine at high idle. Failure to keep water pump speed below 2,400 RPMs will result in water pump failure.

SPRAY BAR WATER PRESSURE:

_____ PSI

SECTION 5

Water Pumps

M-4 WATER PUMP DESCRIPTION

The Mega M-4 is an open centrifugal type water pump mounted to the water tank. It supplies water pressure and flow for tank mounted spray heads, monitor, dump bar, and hose reel. The water pump shaft is driven clockwise (CW) by a hydraulic motor mounted to the water pump bracket.

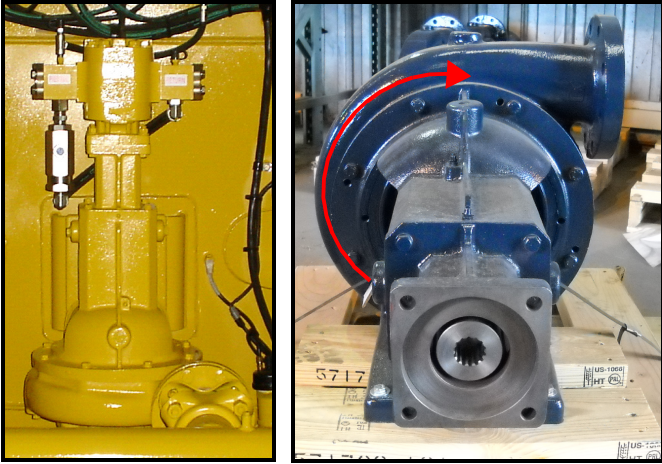

Left-hand image shows an installed M-4 Pump. Right-hand image shows the M-4 pump's clockwise rotation as viewed from the drive end of the water pump assembly.

⚠ WARNING

Due to the nature of these processes, ensure that all safety information, warnings and instructions are read and understood before any operation or any maintenance procedures are performed. This service function takes place with heavy components and at moderate heights, ensure all proper safety procedures and equipment are maintained when performing this service. Failure to use and maintain proper safety equipment and procedures will cause personal injury, death or damage to equipment.

M-4 Water Pump Major Components And Functions

1. BRACKET – Main frame of the pump that allows a pump to be bolted to the tanker and provides the means to direct mount the hydraulic drive motor.
2. VOLUTE CASE – A “snail shell” shaped case that encloses the impeller. It is narrow at the center and enlarges from there to the discharge area.
3. WEAR RING – Acts as a bearing surface between the impeller and volute case. Constructed of bronze material.
4. IMPELLER – Rotating wheel attached to the shaft that accelerates the speed of the water producing water flow and pressure.
5. SHAFT SEAL – Confines grease to the inner and outer bearing area while keeping foreign material from entering the bearing area and seals water inside the volute case.
6. ROPE SEAL – Provides a seal around the rotating pump shaft at the volute case. Constructed of a graphite rope material that is designed to drip water and allow shaft lubrication.
7. UPPER/LOWER BEARINGS - Provide roller surface for the pump shaft.

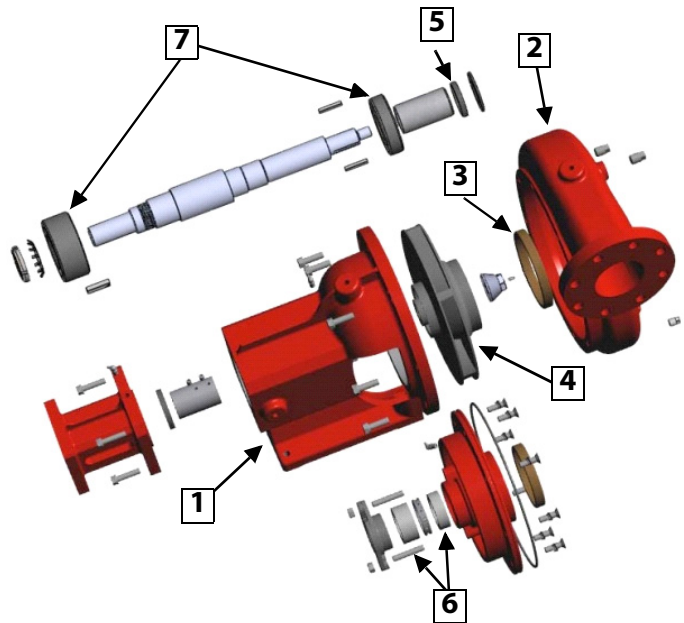

SECTION 5

Water Pumps

INITIAL OPERATION AND IN-SERVICE OF M-4 PUMP

Prior to the initial operation of the water pump, ensure the 2 shaft bearings and lantern ring are lubricated. The drive end bearing will receive 2 fl. oz (60 cc) of grease and the impeller end bearing will receive 2 fl. oz (60 cc) of grease and 5 squirts of grease in the lantern ring grease fitting. Ensure the grease is injected by a manual grease gun only.

CAUTION

- Measure the grease gun discharge to be used in this operation to ensure that the volume required is properly applied. Each grease gun will have a different volume per stroke and will need to be measured. If insufficient or excess grease is applied damage to water pump may result.
- Lubrication of the M-4 water pump must be done using a manual grease gun only. If an auto-lube device, power grease gun or remote lubrication hoses are used, over or under lubrication may result, causing severe bearing and seal damage or failure.

After initial system operation check and prior to in-service operation of water tanker, inspect and adjust the following:

1. Fill unit with sufficient water to perform dynamic system checks (above the level of the rear spray heads).
2. Adjust all of the spray head pattern adjustment rings to the widest opening.
3. Inspect water pump shaft seal for leaks, adjust rope packing glands as required.

4. Operate spray system and check for proper system operation for 2.5 minutes at high idle.

CAUTION

- Limit water pump operation to 2.5 minutes when in a no-flow condition (not flowing water through spray heads, dump bar, water cannon, drain valve, or hose reel). Water pump operation in a no flow condition will cause overheating of the water pump and damage to the shaft seals and bearings.
 - Do not operate the water pump in a dry sump. Dry operation will result in shaft seal damage.
 - Do not engage/disengage the water pump above LOW IDLE. Engaging/disengaging the water pump above low idle will result in water pump component damage and reduced service life.
5. Return system to LOW IDLE and check for shaft seal leakage.
 6. Shut water pump OFF.
 7. Shut spray SYSTEM OFF and remove electrical and hydraulic power from unit.
 8. If shaft rope packing leakage is more than the desired 1 drop per second, adjust shaft rope seal packing gland by tightening the retaining nuts evenly until the desired leakage rate is achieved.

CAUTION

This type of shaft rope packing seal is designed to leak a small amount of water (2 drops per second at the minimum). Failure to allow some water leakage will cause premature rope packing failure and shaft sleeve damage. Over-tightening the packing gland will cause packing mount, packing gland, shaft, shaft sleeve and shaft rope packing seal damage.

SECTION 5

Water Pumps

9. Adjust shaft seal packing gland as instructed to minimize water leakage.

NOTE

- After water tanker has been in operation several hours, recheck shaft rope packing seal for leakage. Readjust as necessary, using caution not to over-tighten packing gland.
- If water tanker contains water and service is required to chassis and the unit is unable to discharge its contents, manually apply 4 or 5 squirts (injections) of grease to the lantern ring grease fitting until the water leakage is minimized or stopped.

M-4 ROUTINE MAINTENANCE

Rope Seal Replacement

⚠ WARNING

Ensure machine is prepared for service and no potential hazards exist. Follow all proper safety procedures and use all required PPE when performing this service. Failure to ensure all safety procedures are followed and PPE is worn may result in serious personal injury or death.

NOTE

Rope packing replacement can be performed without removing the water pump from the water tanker.

1. Remove packing gland.



2. Remove old rope seals.



3. Install one rope seal at a time while indexing the seal gaps 180° from each other.
4. Install the lantern ring after 2 rope packings have been placed in the packing mount.
5. Install the remaining 3 rope packings in the packing mount following the direction of offsetting the seal gap 180°.
6. Install packing gland, snug the retaining nuts, grease lantern ring with 4 or 5 injections of grease.
7. Follow the initial operation guidelines to adjust rope packing gland to achieve the minimum leakage rate of 2 drops per second.

CAUTION

Do not over-tighten packing gland. When installing new packing snug gland retaining nuts. If adjustment is necessary evenly tighten retaining nut to slow water leakage. If gland nuts are over-tightened shaft, packing, gland and shaft damage will occur. This rope packing type seal is designed to weep water (about 2 drops per second).

SECTION 5

Water Pumps

M-4 REPAIR (304991/304992)

The M-4 impeller is secured to the shaft by several different means. These configurations are known as:

<u>GENERATION 1:</u>	Bolt & Lockwasher (Obsolete)
<u>GENERATION 2:</u>	Impeller Retaining Nut with Set Screw (Obsolete)
<u>GENERATION 3:</u>	Impeller Nut & Roll Pin

Ensure you have the correct parts to reassemble the water pump before repairs begin.

Water Pump Removal

1. Ensure water tank is empty.
2. Remove all electrical/hydraulic power and make the vehicle safe for maintenance.
3. Remove hydraulic motor and associated hydraulic lines.

CAUTION

Ensure all open hydraulic lines are capped to prevent hydraulic system contamination.

NOTE

Some water pump installations allow the hydraulic motor to be detached without removing associated hydraulic lines.

4. Remove system piping from the discharge port of the volute case.

NOTE

In some applications extensive disassembly may be necessary to remove water pump from unit. Observe and follow all safety procedures when performing this operation.

5. Remove water pump to sump mount bolts and remove water pump.

Water Pump Disassembly And Inspection

Volute Case

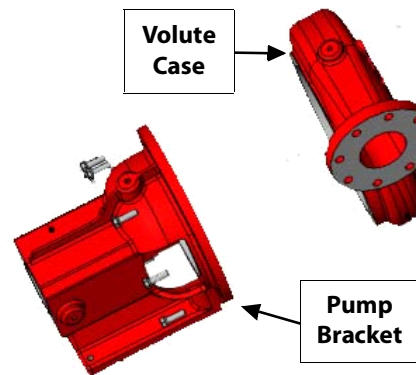

1. Remove volute case mounting bolts and separate volute case from pump bracket. Use the jack screw holes on the pump bracket to assist in separating the volute case from the pump bracket.

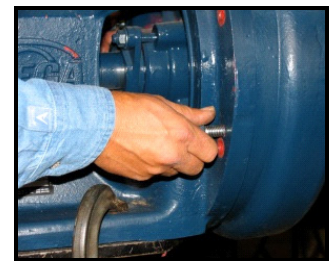

2. Inspect the volute case for the following:
 - a. Case for damage, cracks, and excessive pitting.
 - b. Wear rings for wear and damage.
 - c. Contact wear from impeller inside of the volute case.

SECTION 5 Water Pumps

Impeller

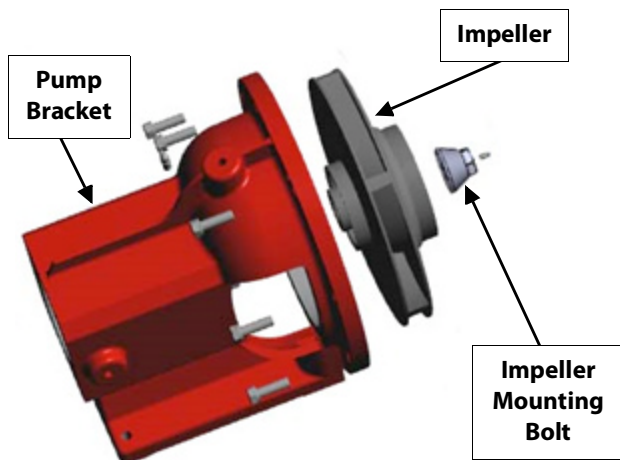

1. Remove impeller mounting bolt, impeller, and keys.

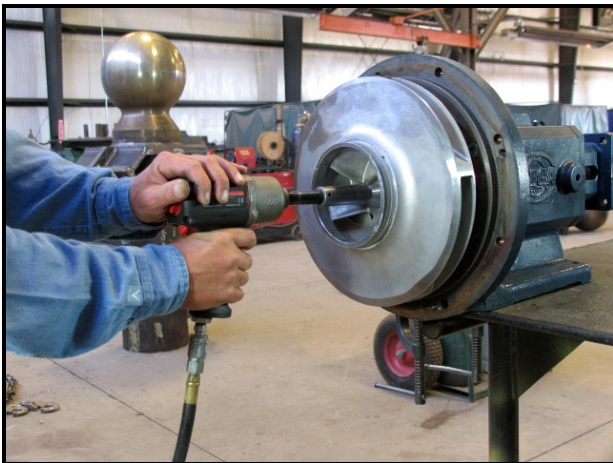

Generation 2 Impeller Retaining Nut

CAUTION

This generation of pump shafts incorporates a locking set screw to secure the retaining nut to the end of the shaft. If the set screw is not loosened damage to the nut, impeller or shaft may result.

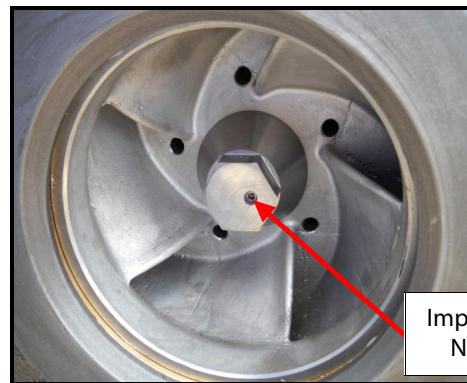

2. Inspect impeller for the following:
 - a. Security and intact retaining bolt/nut.
 - b. Impeller face and keyed shaft area for damage, volute case contact and condition.
 - c. Wear rings and impeller wear surfaces for wear and damage.
 - d. Impeller edge for damage, cracks and condition.
 - e. Inspect keys and shaft key slots for damage, wear, and signs of heat.

SECTION 5

Water Pumps

Generation 3 Impeller Retaining Nut

CAUTION

This Generation retaining nut incorporates a roll pin to prevent nut from loosening upon sudden stoppage of water pump shaft. It is imperative that the installation instructions for this pin be followed exactly. Failure to install pin correctly may cause shortened water pump service life or total pump failure.

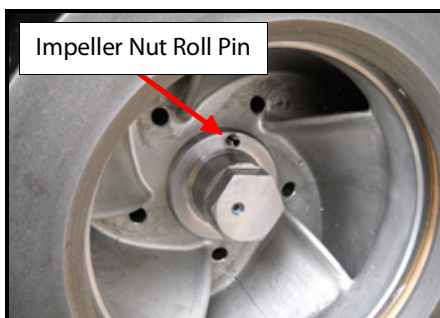

3. Apply a liquid thread lock (LOCTITE® 277 or equivalent) to the shaft threads.
4. Install nut on shaft and torque to 234 ft/lbs. (318 nm).
5. If applicable, tighten set screw (found only on early models).
6. Using drill fixture (pt # 306011), drill a 0.1875" hole through nut into impeller (hole must be drilled to a depth of 0.500" into the impeller).

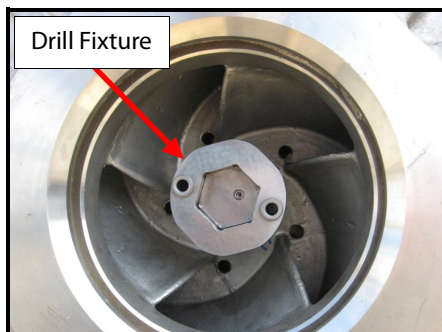

7. Remove drill fixture.
8. Install roll pin into hole.

Packing Mount

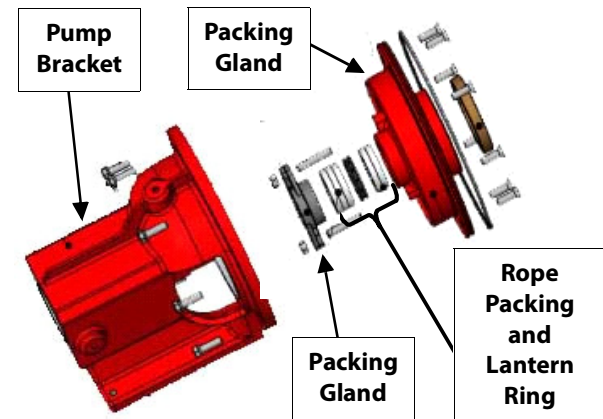

1. Remove the packing mount countersunk mounting bolts. Use the 2 jack screw holes located on the pump bracket to assist in pressing out the packing mount.

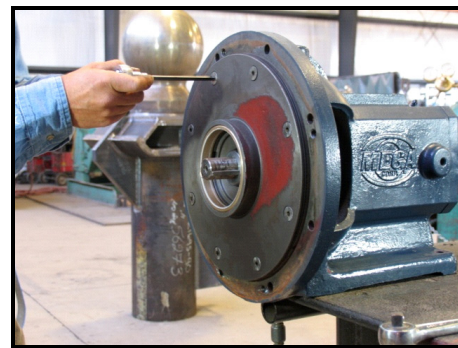

2. Inspect the packing mount as follows:
 - a. Packing mount for security.
 - b. Wear ring for damage and condition.
 - c. O-ring for damage and condition.
 - d. Remove packing gland and inspect rope seals (3) for wear, condition or signs of overheating.
 - e. Remove lantern ring (1) and inspect for damage and condition.
 - f. Remove rope seals (2) and inspect for wear, condition or sign of overheating.

SECTION 5 Water Pumps

Hydraulic Motor Drive Coupling and Motor Mount

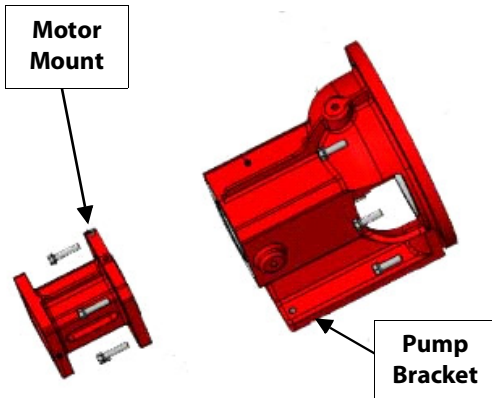

1. Remove hydraulic motor drive coupling and mount bolts and separate mount from pump bracket.

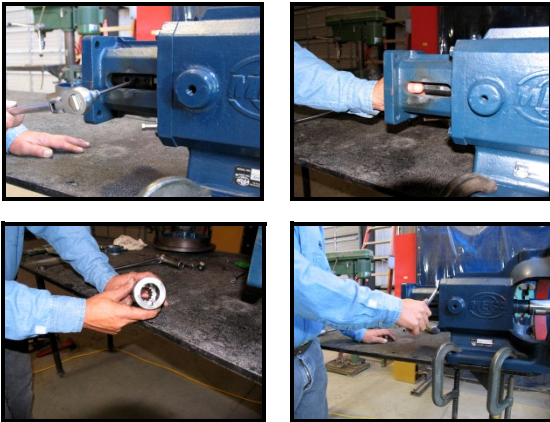

2. Inspect grease seal for damage and condition.
3. Inspect hydraulic motor shaft for wear and damage.
4. Inspect hydraulic motor shaft seal for leaks.
5. Inspect hydraulic motor mount for cracks and damage.

Shaft & Bearing Assembly

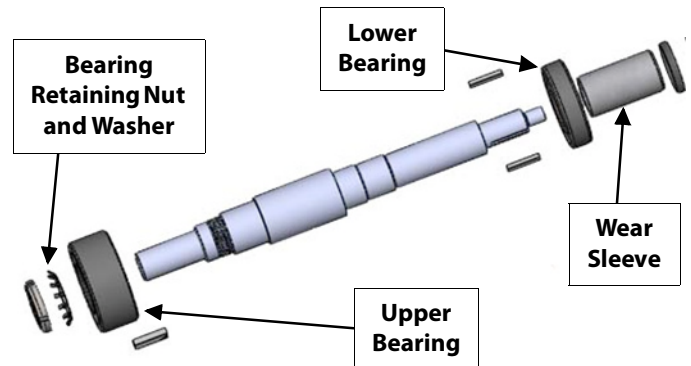

1. Remove shaft and bearing assembly from water pump bracket.



2. Thoroughly clean inside of pump frame to ensure no old grease remains in pump frame.

SECTION 5 Water Pumps

3. Disassemble shaft assembly as follows:
 - a. Remove shaft coupling by removing set screws and applying heat to the coupling.
 - b. Remove snap ring and thrust washer or retaining nut and locking ring. (Previous style Pump shaft)
 - c. Bend bearing retaining nut lock ring tab to clear the locking slot and remove the bearing retaining nut (current style pump shaft).

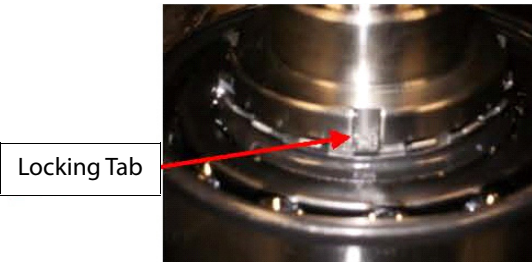

- d. Remove upper bearing.
 - e. Remove sleeve set screws, apply heat and remove rope packing seal wear sleeve, grease seal and lower bearing.

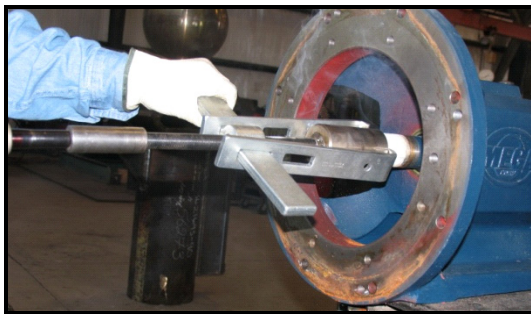

4. Inspect shaft and bearing assembly as follows:
 - a. Shaft for damage, cracks and condition.
 - b. Upper and lower bearings for damage, excessive play and freedom of rotation.
 - c. Grease seal for damage and condition.
 - d. Wear sleeve for damage and condition.

5. Reassemble shaft assembly as follows:

CAUTION

Manually pack the shaft bearings with grease prior to installation. Failure to ensure adequate lubrication of the bearings will result in shortened service life, bearing, shaft and possible water pump damage or failure.

- a. Install lower bearing, thrush washer and snap ring.
 - b. Install upper bearing, thrust ring and snap ring or bearing retaining nut and lock ring.
 - c. Torque bearing retaining nut to 50 ft-lbs (68 nm).
 - d. Secure the lock ring tab when torqued.



- e. Pack upper and lower bearings with grease.

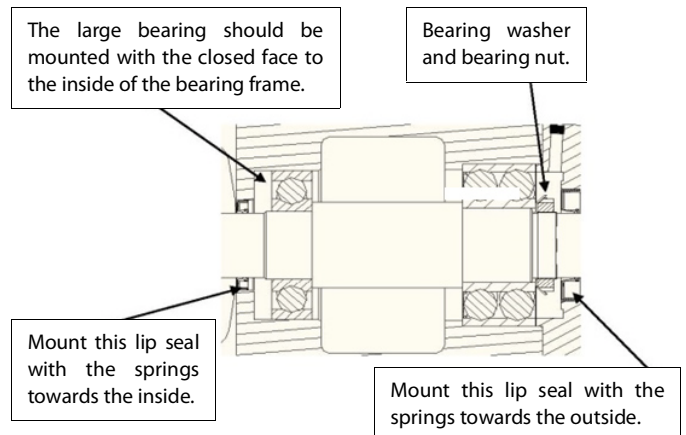

SECTION 5

Water Pumps

M-4 WATER PUMP REASSEMBLY

1. Remove all grease from the pump bracket bearing cavities.
2. Install grease seal in bracket assembly (lip side IN).

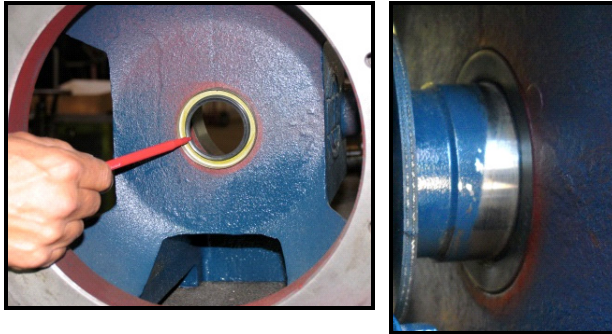

3. Ensure upper and lower bearings are packed with grease and install shaft and bearing assembly in the water pump bracket.

CAUTION

Use care when inserting the shaft into the pump bracket. Ensure the shaft does not damage the front seal when installing the shaft in the pump bracket. Failure to use caution when installing shaft and inspecting the seal for seal damage after the shaft is installed may result in shortened service life or pump, bearing and shaft damage.

4. Install drive motor mount with grease seal (lip side OUT) and torque the mount bolts to 60 ft-lbs (82 nm).

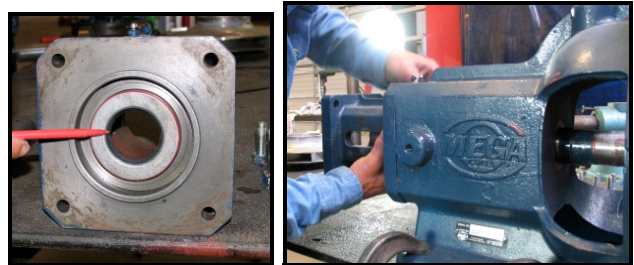
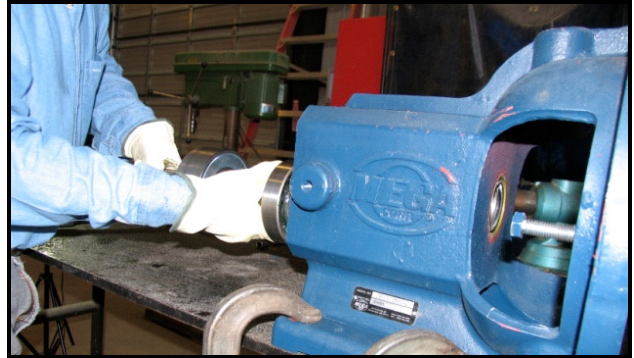

NOTE

To aid in assembly/disassembly, coat all fastener threads that are installed into blind threaded hole with an anti-seize compound prior to the installation of the fastener.

5. Install slinger on shaft.
6. Install drive motor coupling with LOCTITE® and tighten set screws and torque the set screws to 12 ft-lbs (17 nm).



SECTION 5

Water Pumps

7. Install wear sleeve with LOCTITE®.



8. Install assembled packing mount with rope seals, packing gland, lantern ring and wear ring.



9. Install 8 mount bolts and plastic inserts.
10. Torque mount bolts and torque to 20 ft-lbs (27 nm).



11. Coat impeller balance ring area and packing mount wear ring with anti-seize or equivalent lubricant.

12. Install shaft keys and impeller on lower end of the shaft.

13. Install, LOCTITE® and tighten impeller spinner nut.

14. Install and LOCTITE® spinner nut set screw.



15. Torque Impeller spinner nut to 234 ft-lbs (318 nm)

16. Tighten set screw.

17. Ensure packing mount O-ring is lubricated, installed and seated.

18. Coat volute case wear ring with anti-seize or equivalent lubricant.



19. Install volute case with wear ring and tighten 8 mount bolts. Torque Volute case bolts to 80 ft-lbs (108 nm) in a criss cross pattern.

SECTION 5 Water Pumps

20. Lubricate water pump drive motor end bearing with 2 fl. oz. (60 cc) and the impeller end bearing with 2 fl. oz. (60 cc) of grease. Lubricating the shaft rope seal (Lantern ring) by applying 5 squirts (injections) of grease.

M-4B WATER PUMP



An open centrifugal type water pump mounted to the water tank supplies water pressure and flow for tank mounted spray heads, water cannon, dump bar, and hose reel. The water pump shaft is driven clockwise (CW) by a hydraulic motor mounted to the water pump bracket.

Water pump major components and their function are:

1. BRACKET (BEARING FRAME) – Main frame of the pump that allows a pump to be bolted to the tanker and provides the means to direct mount the hydraulic drive motor.
2. VOLUTE CASE – A “snail shell” shaped case that encloses the impeller. It is narrow at the center and enlarges from there to the discharge area.
3. WEAR RING – (Contains 2) Acts as bearing surfaces between the impeller and volute case as well as the impeller and the seal plate (seal plate). Constructed of stainless steel material.
4. IMPELLER – Rotating wheel attached to the shaft that accelerates the speed of the water producing water flow and pressure.
5. SEAL PLATE – Mounts to the pump bracket and faces the impeller. Reduces dynamic impeller vibrations and is used to hold the Volute seal and shaft seals.

6. PACKING RINGS – Provides a seal around the rotating pump shaft at the volute case. Constructed of a graphite rope material that is designed to drip water and allow shaft lubrication and cooling.
7. UPPER/LOWER BEARINGS - Provide roller surface for the pump shaft.

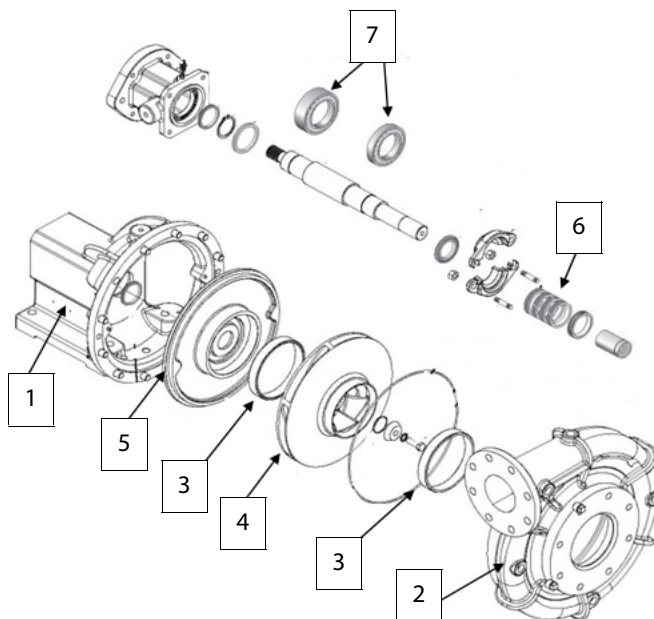

M-4B ROUTINE MAINTENANCE AND REPAIR

CAUTION

Do not over-lubricate bearings. Over-lubricating bearing will cause bearings to run hot and overheat causing bearing, shaft and pump failure.

NOTE

Grease requirements: Lithium-based NGLI No 2 Extra Pressure Ball Bearing Grease is required. The following are factory approved brands of grease for the M4B water pump: Alvania EP2 (Shell Oil), Mobilith AW2 (Mobile Oil), Ronex MP (Exxon), Litholine EP2 (Atlantic Richfield) and Amolith EP2 (Amoco).

SECTION 5

Water Pumps

Rope Seal Replacement

NOTE

This procedure can be done without removing water pump from tank and is considered routine maintenance.

1. Ensure water tank is empty.
2. Remove packing gland.
3. Remove old rope seals.



Packing Mount Removed From Pump for Clarity

4. Install one rope seal at a time while indexing the seal gaps 180 degrees from each other.
5. Install packing gland and hand tighten nuts evenly, fill unit with water, operate water pump and allow packing to liberally leak for a few moments.

CAUTION

Do not operate the water pump in a dry sump. Dry operation will result in shaft seal damage.

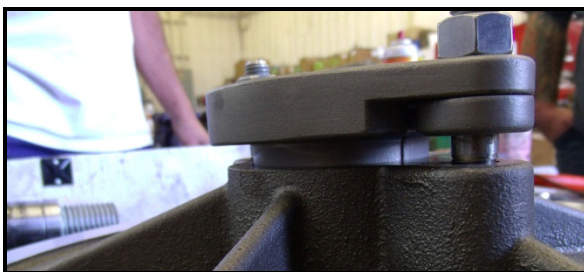

6. Tighten gland nuts evenly 1 complete turn each until leakage is reduced to 40 to 60 drops per minute.

NOTE

Water should not be streaming or spraying from seal area. Inspection, adjustment or replacement will be required if these conditions exist.

Water Pump Removal

1. Ensure water tank is empty.
2. Remove all electrical/hydraulic power and make the vehicle safe for maintenance.
3. Remove hydraulic motor and associated hydraulic lines.

CAUTION

Ensure all open hydraulic lines are capped to prevent hydraulic system contamination. Contamination will damage hydraulic system and components.

NOTE

Some water pump installations allow the hydraulic motor to be detached without removing associated hydraulic lines.

4. Remove system piping from the discharge port of the volute case.
5. Remove water pump to sump mount bolts
6. Remove frame mounting bolts and remove water pump.

NOTE

Additional components may require removal, depending on tank configuration.

SECTION 5 Water Pumps

M-4B WATER PUMP DISASSEMBLY AND INSPECTION

Volute Case

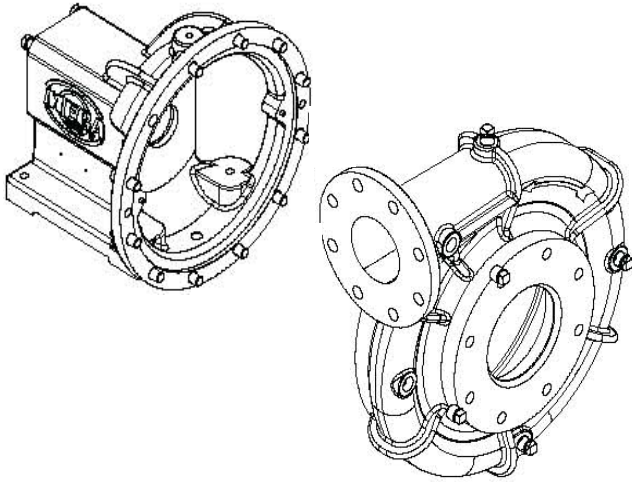

1. Remove volute case mounting bolts and separate volute case from pump bracket.
2. Use jack bolt (2) holes to unseat volute case from frame.

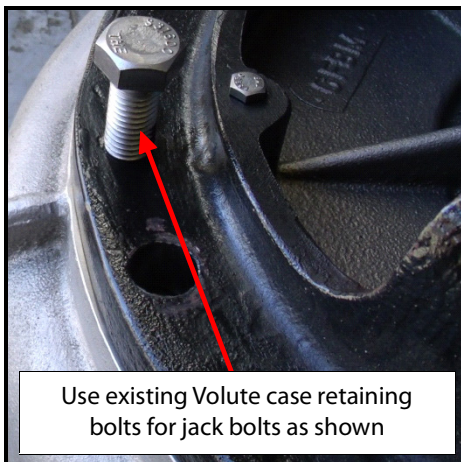

3. Inspect and clean O-ring groove in volute case.
4. Inspect the volute case for the following:
 - a. Case for cracks, corrosion, wear and excessive pitting.
 - b. Wear ring for scoring and condition.
 - c. Inspect threaded bolt holes and sealing surfaces for damage, condition, cracks and corrosion.

Impeller

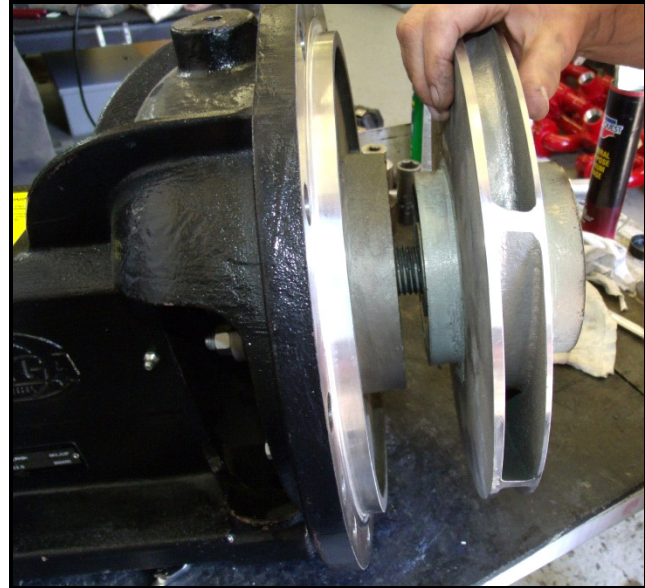

1. Hold impeller stationary and remove impeller mount bolt, impeller washer, lock washer and O-ring.
2. Hold shaft stationary and turn impeller **Counter-clockwise** to remove impeller from the shaft.

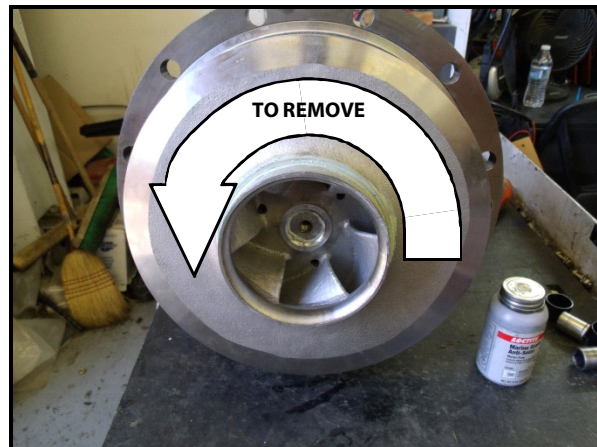

3. Inspect impeller for the following:
 - a. Impeller face for cracks, corrosion and condition.
 - b. Impeller edge for damage, cracks and condition.
 - c. Bolt, washers, O-ring and threads for damage and condition.
 - d. Seal mount wear ring and rear surface of impeller for damage and condition.
 - e. Impeller shaft threads for damage and condition.

SECTION 5

Water Pumps

Seal Plate

1. Remove seal plate mount bolts (2).

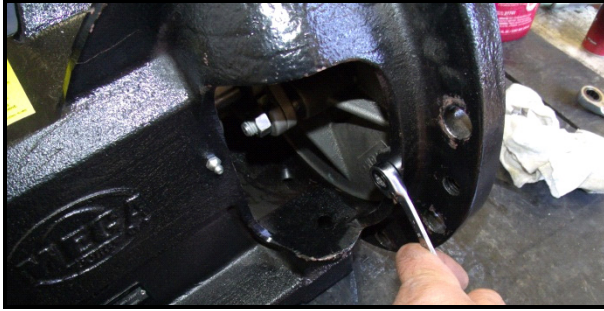

2. Install longer ¼ -20 bolts and thread into seal plate (approximately 4" long bolts).
3. Using a soft face mallet, strike each bolt until seal plate is free from pump frame.
4. Remove bolts from seal plate.
5. Inspect the seal plate as follows:
 - a. Seal plate for cracks, corrosion, scoring and condition.
 - b. Wear ring for damage and condition.
 - c. Packing gland studs and nuts for damage and condition.
 - d. Packing seal bore for damage and condition.
 - e. Volute O-Ring sealing surface for damage and condition.

Packing Assembly

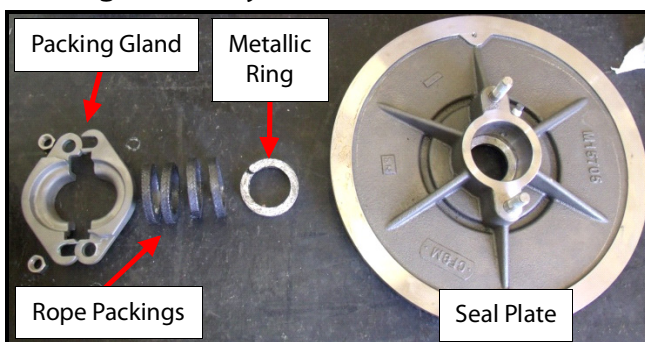

1. Remove packing gland nuts and remove packing gland.
2. Remove packing rings.
3. Remove Metallic ring.

4. Inspect the assembly for the following:
 - a. Packing gland for cracks, corrosion and condition.
 - b. Packing rings for wear, damage and signs of overheating.
 - c. Metallic ring for wear, damage and signs of overheating.
 - d. Wear sleeve for wear, damage, corrosion and signs of overheating.

Shaft & Bearing Assembly



1. Remove drive coupling from shaft.
2. Remove drive motor mount from frame.



3. With a soft face mallet drive shaft and bearing assembly out of the frame towards the drive end.



SECTION 5

Water Pumps

4. Disassemble shaft assembly as follows:
 - a. Remove snap ring and thrust ring from drive end of shaft.

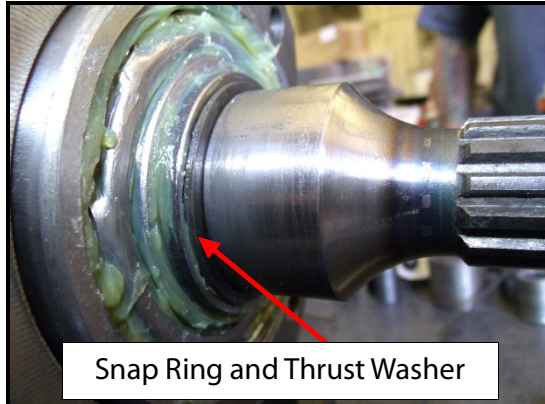

- b. Remove drive end bearing.
 - c. Remove impeller end bearing.
5. Inspect shaft and bearing assembly for the following:
 - a. Shaft for cracks, condition and any signs of overheating.
 - b. Bearings for damage, condition, freedom of rotation, excessive play and any signs of overheating, water infiltration or lack of lubrication.
 - c. Wear sleeve for damage, scoring, corrosion, signs of overheating and wear.
 - d. Impeller threads for damage, condition and wear.
 - e. Drive end splines for damage, cracking, condition and wear.
6. Inspect frame for damage, condition, cracks, corrosion, signs of overheating and wear.
7. Inspect drive motor mount for damage, cracks, condition and signs of overheating.

M-4B WATER PUMP REASSEMBLY

Shaft Assembly

1. Ensure frame, shaft and bearings are clean and free of debris.
2. Dress shaft with fine emery cloth and wipe clean.
3. Slip new wear sleeve onto shaft for trial fit (sleeve should slip onto shaft smoothly) remove sleeve.

4. Apply Loctite® 277 to inside of sleeve.



5. Install sleeve onto shaft, wipe away excess Loctite®.
6. Pack bearings with a lithium based grease NLGI No. 2 Extra Pressure ball bearing grease. Ensure the bearing cage and bearings are lubricated prior to installing shaft into frame.
7. Press bearings onto shaft.
8. Install thrust ring and snap ring to retain drive end bearing.

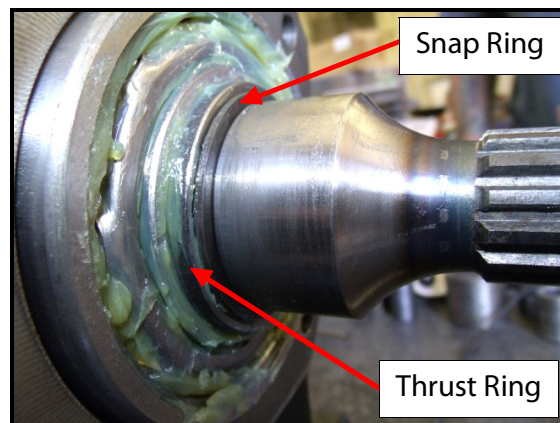

SECTION 5

Water Pumps

Shaft Installation

1. Install impeller end frame seal. This seal is installed lip side **towards** the inside of the frame. Ensure seal is flush with outside of frame casting. Liberally lubricate seal lip with grease.



2. Install motor mount seal. This seal is installed with the lip facing **away** from the frame. Ensure seal lip direction is correct and ensure seal is flush with the motor mount casting. Liberally lubricate seal lip with grease.



3. Coat inside of bearing bores with grease to ease installation of shaft assembly.
4. Insert shaft assembly into frame from the drive end. Carefully slide shaft through the impeller end seal, using caution not to damage or invert seal lip.

CAUTION

Use caution to install shaft through the impeller end seal. Damaging or inverting seal lip will result in bearing and water pump failure.

5. Using a soft face mallet, drive shaft into frame until fully seated.

6. Apply Loctite® 277 to threads of motor mount bolts.
7. Install motor mount and torque bolts to 50 ft/lbs (68 nm). Use caution when installing mount to not damage seal lip.
8. Manually lubricate water pump bearings with lithium based grease NLGI No. 2 EP (Extreme Pressure) grease; 5.5 fl oz (150 cc) of grease to the drive end bearing and 2.5 fl oz (75 cc) of grease to the impeller end bearing.

Grease requirements for the M4B pump:

Lithium-based, NLGI No 2 EP (extreme Pressure).

NOTE

The M4B pump is equipped with a frame vent hole in the bottom of the frame. This port is used to vent excess pressure and grease from frame. Do not plug this hole.

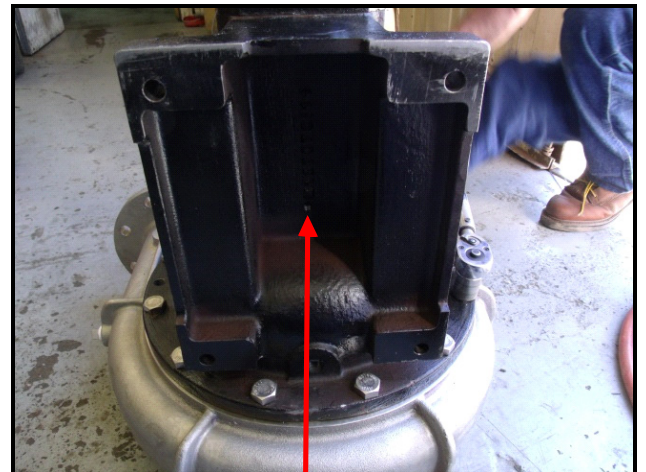

SECTION 5 Water Pumps

Seal Plate Installation

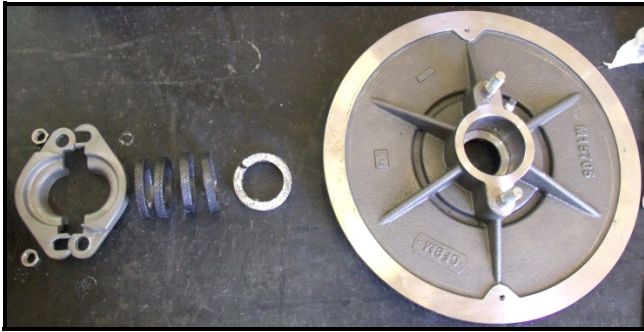

1. Install rope seal packing in seal plate as follows.
2. Ensure seal plate is clean and in good condition.
3. Install metallic ring in seal bore.

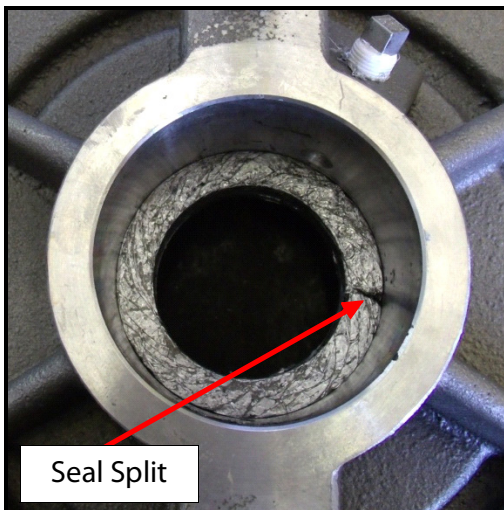

4. Install one rope seal at a time while indexing the seal gaps 180 degrees from each other.

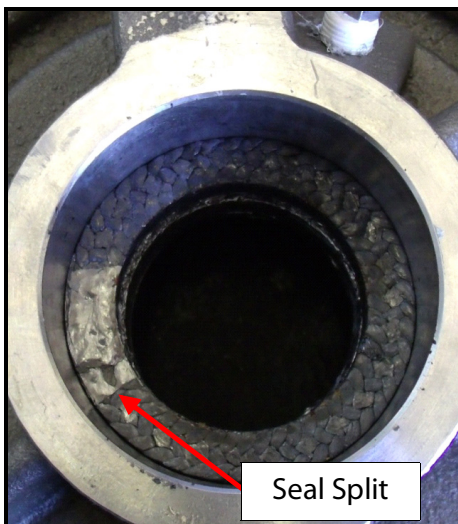

5. Install packing gland and hand tighten nuts evenly.

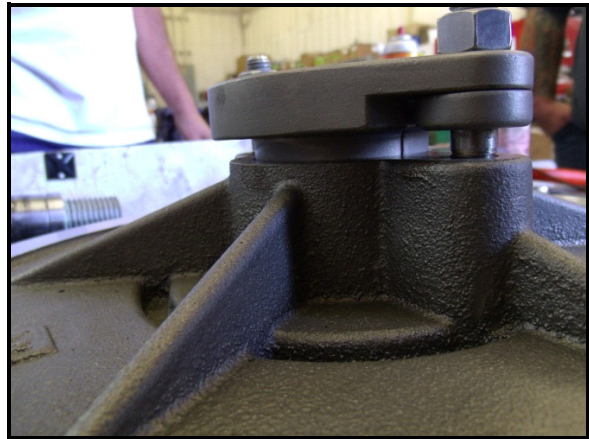

6. Install slinger onto shaft.

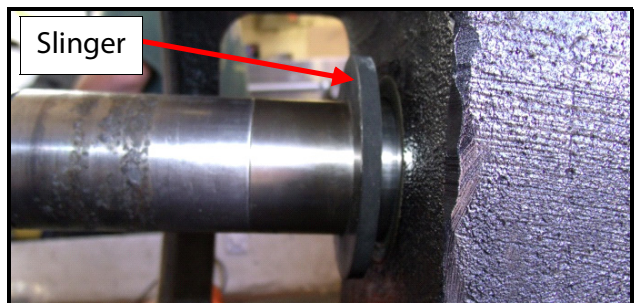

7. Apply Anti-Seize to seal plate mounting surface on frame.



SECTION 5 Water Pumps

8. Install seal plate to end of frame.



9. Line up jack bolt holes in frame and seal plate.

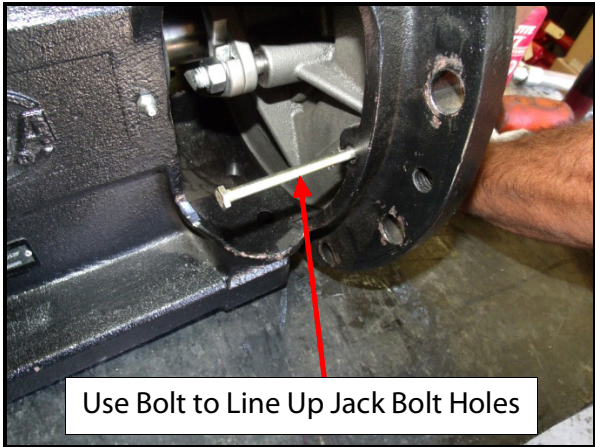

10. Evenly, gently tap plate with a soft face mallet until it seats on frame.

11. When plate is seated, remove line up bolts and install seal plate retaining bolts.

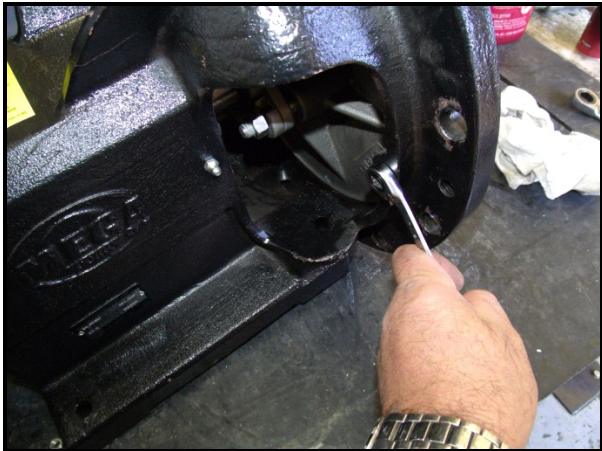

Impeller Installation

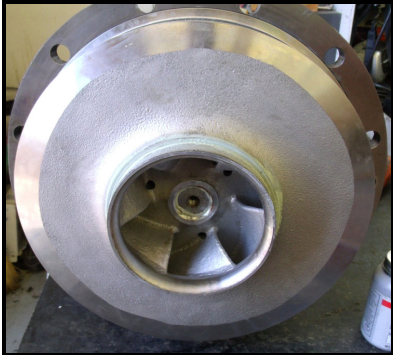

1. Liberally apply grease to balance ring bushing on seal plate.



2. Apply Anti-Seize to impeller threads.



3. Thread impeller onto shaft.

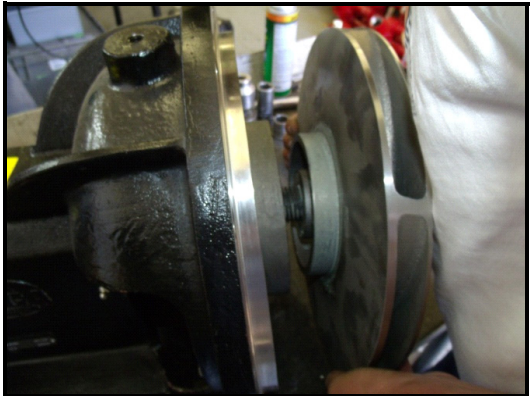

SECTION 5

Water Pumps

4. Hold shaft in place and tighten impeller **Clockwise** until tight.

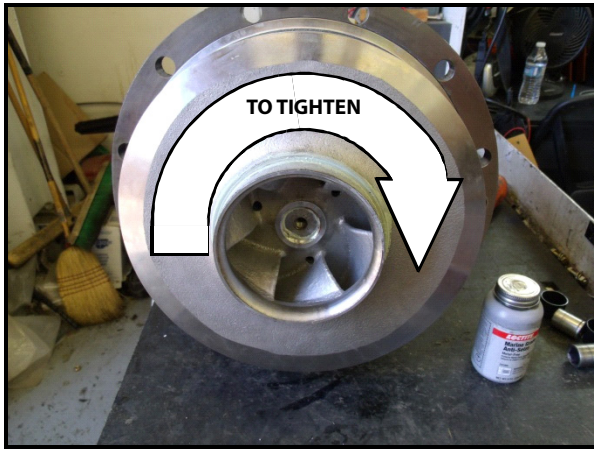

5. Stack lock washer, impeller washer and O-Ring on retaining bolt.



6. Apply Loctite® 277 to retaining bolt and lubricate O-Ring with a light coat of grease.



7. Install impeller retaining bolt and torque to 50 ft-lbs (68 nm).



Volute Case Installation

1. Liberally apply grease to the wear surface on the inlet of impeller.



2. Install volute case O-Ring seal to seal plate. Coat liberally with grease.

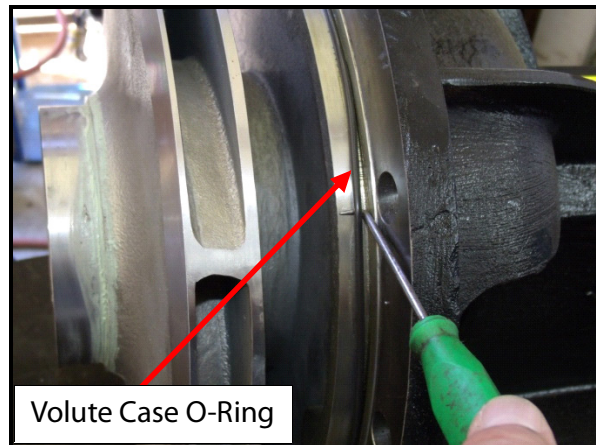

3. Install volute case on pump frame. Ensure volute outlet is in the orientation required for installation.

4. Apply Loctite® 277 to volute case bolt threads.



5. Torque volute case bolts to 100 ft-lbs (135 nm).

SECTION 5

Water Pumps

Water Pump Installation

1. Remove old gasket material from mounting flanges. Replace as required.
2. Locate water pump on inlet flange with the required gaskets. Tighten inlet flange and pump mount bolts.
3. Remove old gasket material from water pipe discharge pipe. Replace as required.
4. Install all components that were removed when removing water pump. Tighten hardware.
5. Manually lubricate water pump drive motor end bearing with 5.5 fl. oz. (150 cc) and the impeller end bearing with 2.5 fl. oz. (75 cc) of grease.

CAUTION

Ensure the water pump bearings are greased with the proper amount of grease prior to operation. Failure to ensure the water pump shaft bearings are adequately and properly lubricated will result in shortened service life, as well as bearing, shaft and possible water pump damage or failure.

6. Inspect shaft coupling for damage and replace if required.
7. Install hydraulic drive motor and associated hosing. Tighten all mounting bolts.
8. Operate water pump system while checking for leaks as well as component operation.
9. Install hydraulic drive motor and associated hosing. Tighten all mounting bolts.
10. Operate water pump system while checking for leaks as well as component operation.

M-4/M-4B FUNCTIONAL CHECK & RPM ADJUSTMENT

These procedures are designed to perform dynamic checks of the water pump system and perform RPM adjustments if required. This process also provides information in troubleshooting water pump systems.

CAUTION

Ensure MTT and truck is configured for water truck application before proceeding with this test. Improper configuration may result in damage to chassis and tank.

1. Install hydraulic test gauges on the hydraulic motor quick disconnect test ports.
2. Install water pressure gauge on the spray bar assembly ball or gate valve.
3. Fill water tank with a sufficient amount of water to perform water pump RPM adjustment and functional check of all water spray systems to include the water cannon (if equipped).

CAUTION

Do not operate the water pump in a dry sump. Dry operation will result in shaft seal damage.

4. Once tank is full, check pump couplings for static leaks.
5. Adjust all spray head adjustment rings to full flow and maximum pattern width to allow free flow of metal contaminants during testing.
6. Ensure all cab control switches are in the OFF position.

Electrical Power On And Engine Off

7. Ensure vehicle battery power is connected.
8. Ensure all cab control switches are in the OFF position.

SECTION 5

Water Pumps

9. Turn vehicle key switch ON (engine off). Ensure the vehicle cycles through recommended ECM functions per chassis specific Operators Manual and all warning and advisory lights extinguish.

Electrical Power On And Engine On

10. Ensure the area around the vehicle is well clear and ample space is available to operate spray heads and water cannon.

⚠ WARNING

Ensure that all available openings are oriented away from personnel and equipment before beginning. Water may be discharged from any of the available openings when performing this test function. Improperly aimed openings may cause personal injury or damage to equipment.

11. Ensure wheels are chocked, parking brake is set and vehicle is safe to operate.
12. Start up the vehicle and ensure all required warning and advisory lights extinguish per chassis specific Operators Manual.
13. While the vehicle is running inspect all installed water pump hydraulic components and hoses for leaks.
14. Ensure all spray heads, dump bar, drain valve, MONITOR/BFV, and foam switches are in the OFF position.
15. Turn the cab control box SYSTEM/POWER switch ON.

16. Turn the cab control box PUMP switch ON. Inspect all water pump and associated water components (torque tube manifold, water pump hydraulic drive motor and cross-over) connections and hoses for leaks.

CAUTION

Do not engage/disengage the water pump above LOW IDLE. Engaging/disengaging the water pump above low idle will result in water pump component damage and reduced service life.

17. Ensure water pump shaft is rotating in a CW direction.
18. Inspect vehicle hydraulic tank to ensure sufficient fluid level is available for continuing test. If sufficient fluid is not available shutdown vehicle, service hydraulic tank and restart vehicle.

CAUTION

Ensure the MTT is filled with sufficient water to perform operational test. Maximum capacity is recommended. Operating the water pump in a dry sump will result in shaft seal damage.

19. Increase engine RPM to normal operating range and check all installed water pump components and hoses for leaks.
20. Note hydraulic pressure and return readings as well as water pump pressure at about 2,100 engine RPM on work sheet provide in the rear of this tech manual.
21. Reduce engine speed to LOW idle.
22. Turn water pump OFF.
23. Turn system OFF.
24. Shutdown vehicle.

SECTION 5

Water Pumps

M-4/M-4B WATER PUMP RPM ADJUSTMENT

1. Clean water pump shaft and install reflective tape just above the packing gland.
2. Install a photo tachometer to measure water pump shaft speed or prepare hand-held device.
3. Adapt a water pressure gauge to the rear spray bar ball or gate valve.
4. Start up vehicle.
5. At LOW IDLE turn the cab control SYSTEM/POWER switch ON, then the PUMP switch ON.

CAUTION

- Ensure the tank is filled with sufficient water to perform operational test. Operating the water pump in a dry sump will result in shaft seal damage.
 - Do not engage/disengage the water pump above LOW IDLE. Engaging/disengaging the water pump above low idle will result in water pump component damage and reduced service life.
6. Ensure the water pump is turning in a CW rotation. Note water pump RPM and spray bar water pressure.

WARNING

Do not place hands or tools within pump bracket while pump is rotating and/or pressure held within the motor supply hose. Failure to follow proper safety procedures could result in serious injury.

7. Operate vehicle at HIGH IDLE. Note water pump speed. Water pump speed should be set to:

M4 PUMP: 1900 ± 50 RPM

M4B PUMP: 1,950 ± 50 RPM

CAUTION

Water pump RPM must not exceed the above specifications with engine at high idle. Failure to ensure water pump speed is at or below specifications will result in reduced spray system component service life.

8. If water pump RPM is too out of the desired range, adjust the water pump hydraulic drive motor flow control valve to obtain specified RPM.

CAUTION

Do not operate water pump at HIGH idle for longer than 2.5 minutes without discharging water from spray heads or monitor. Allowing the water pump to run longer than 2.5 minutes may cause water pump to overheat resulting in damage to the water pump, seals and bearings.

NOTE

The flow control valve can control as much as 35 GPM (135 lpm) or about 700 RPM.

9. Once desired RPM is obtained, tighten jam nut on flow control valve.
10. Reduce engine speed to LOW idle.
11. Turn water pump OFF.

CAUTION

Do not engage/disengage the water pump above LOW IDLE. Engaging/disengaging the water pump above low idle will result in water pump component damage and reduced service life.

SECTION 5

Water Pumps

12. Turn system OFF.
13. Shutdown vehicle.
14. Remove photo tachometer and water and hydraulic pressure gauges.

WATER PUMP TROUBLESHOOTING FAQ

When should I replace gaskets?

Any time that the water pump is serviced and the gaskets are removed, replace the gaskets. Gaskets are inexpensive, and a faulty gasket will cause the pump to leak.

Is my water pump supposed to leak water from around the shaft seal?

Yes; a small amount of water leaking through the shaft seal is necessary to lubricate and cool the rope packing and shaft sleeve. The recommended leakage rate is between 60 and 120 drops per minute, which will result in a small trickle of water. If water leakage is excessive, simply adjust the packing glands to compress the rope packing until leakage is within the recommended parameters.

When should I replace the packing?

Over time as the packing is subjected to continual heat and pressure through normal use, lubricant will be forced out of the packing material. The life of the packing material can be extended by periodically tightening the packing gland whenever there is packing leakage greater than the specified amount (Mega's rope packing seals are designed to leak approximately 60 drops per minute). Eventually, however, all of the lubricant will have been squeezed out of the packing material, and tightening the packing gland will no longer prevent leakage. When this happens, it is time to replace the packing.

Why should the pump never be run dry?

The water pump shaft and impeller are spinning at extremely fast rates. With no water to transfer their rotational energy to, that energy is released as heat instead. If the pump is run dry, its moving parts will become extremely hot, causing severe damage to the pump over time and greatly limiting its service life.

Why did the pump shaft break?

Broken/cracked shafts are most often the result of excessive vibration or imbalance, and it is usually a bearing that fails as a result of overload, causing the shaft to break. Bearing failure can happen very abruptly if there is a sudden shock to the shaft.

What causes pump cavitation?

When the inlet pressure of a water pump falls below pump design specifications, tiny vapor bubbles can form in the water around the eye of the impeller. When the water containing these bubbles is forced into a high pressure environment on the other side of the impeller, these bubbles collapse, thereby creating tiny shock waves and points of high temperature. These shock waves can actually corrode the surface of the impeller. To prevent cavitation, always be sure to operate your water pump within its pressure and flow specifications.

The grease fittings on my M-4B water pump are very small; what size adapter do I need to connect my Auto Lube system to this pump?

The threads will be either 1/8 inch NPT or 5/16-24 NPS thread. The 5/16-24 NPS is a straight-pipe thread, so a male -2 JIC fitting can be screwed directly into the pump frame.

How often should my water pump's bearings be greased? Can an auto-lube be used?

Exact intervals and grease amounts vary depending upon the type of water pump. Refer to Mega's Schedule of Inspections Manual or the Mega Maintenance Manuals for exact instructions and details. Most Mega water pumps should be manually greased; over-greasing can damage bearings and high pressure grease guns can blow out the pump's grease seals, resulting in bearing failure. The exception is Mega's M-4B pump, which can be greased with an auto-greaser or looped into a prime mover's auto greasing circuit.

SECTION 5

Water Pumps

M-4 & M-4B WATER PUMP NOTES

ENGINE RPM – (LOW IDLE)

WATER PUMP DRIVE MOTOR HYDRAULIC PRESSURE - _____ PSI

WATER PUMP DRIVE MOTOR HYDRAULIC RETURN - _____ PSI

ENGINE RPM – (HIGH IDLE)

WATER PUMP SHAFT SPEED - _____ RPM

CAUTION

(M4 Water Pumps)

DO NOT EXCEED 1,950 RPM, WATER PUMP SHAFT SPEED. Failure to keep water pump shaft speed below 1,950 RPM will result in water pump damage or failure. Recommended speed is 1900 ± 50 RPM.

(B4 and M4B Water Pumps)

DO NOT EXCEED 2,100 RPM, WATER PUMP SHAFT SPEED. Failure to keep water pump shaft speed below 2,100 RPM will result in water pump damage or failure. Recommended speed is 1950 ± 50 RPM.

WATER PRESSURE AT SPRAY BAR - _____ PSI

DRIVE MOTOR PRESSURE - _____ PSI

DRIVE MOTOR RETURN - _____ PSI

If your system is not covered in this manual or you are having difficulties with the installation please contact The MEGA Corp. Product Support Group at:

U.S. Toll Free: 1-800-345-8889

Direct: 1-505-345-2661

Or visit our website at www.megacorpinc.com for more contact information.

SECTION 5
Water Pumps

SECTION 6 Spray System

Contents

Hydraulic Spray Head	6-1	Dump Bar (If Equipped)	6-20
Pneumatic Spray Head	6-7	Quick Drain (If Equipped)	6-21
Hydraulic Control Box	6-10	Suction Loading (If Equipped)	6-21
Pneumatic Solenoid Control Box	6-14	Front Bumper Spray Bar	6-23
Pneumatic Butterfly Valve (BFV) Assembly	6-19		

HYDRAULIC SPRAY HEAD



Description

A two piece housing that contains a diaphragm, valve guide disk, spring, hydraulic cylinder and an adjustable flow ring. This assembly is mounted to a base plate that is welded to a pressurized water pipe. Hydraulic pressure from the hydraulic solenoid control box is used to extend the spray head hydraulic cylinder (close diaphragm) or retract (open diaphragm) to control water flow.

The port at the top of the spray head cylinder closes the spray head. The port low on the side of the cylinder opens the spray head by retracting the cylinder rod. An adjustable flow ring is provided to adjust spray pattern, reach and flow.

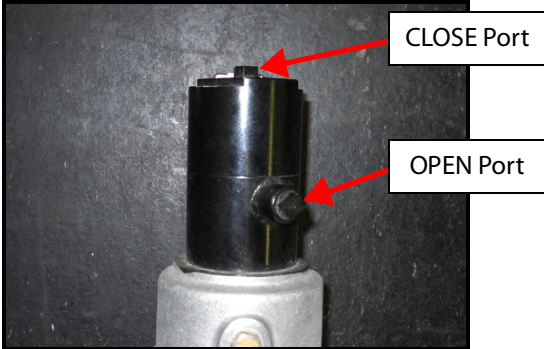

The spray head contains a spring that is designed to hold the guide disk down and keep the spray head closed when the power unit is off and the machine is not in operation. It will only hold static water pressure, it is important to keep replacement pieces on hand. As the guide disks wear they will need to be replaced to prevent water from leaking when the unit is idle and full of water.

Spray Head Adjustable Rings

The adjustable ring is used to control fan width and water flow. The ring may be loosened and rotated to expose more or less of the lower valve opening to control water fan width from 15° to 90°. The ring also may be used rotated to a 1/4" (6.35 mm) or 3/8" (9.5 mm) slot as shown below to increase or decrease overall water flow. The greater the opening the greater the water flow.

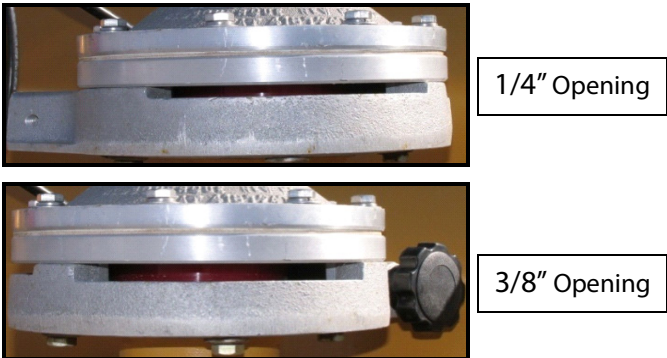

SECTION 6

Spray System

Inspection

1. Inspect hydraulic cylinder and hoses for leaks and security.
2. Inspect upper and lower housings for cracks, damage or evidence of water leaks.
3. Ensure the breather tube is not damaged and the opening is in a position to not allow water or debris infiltration.

CAUTION

If a breather fitting is in the upper casting, it should be replaced with the Upper Housing Breather Port Tube. The guide disk will not fully seat when hydraulic pressure is removed from the closed side of the cylinder causing water to leak when the unit is not operating if this port is obstructed.

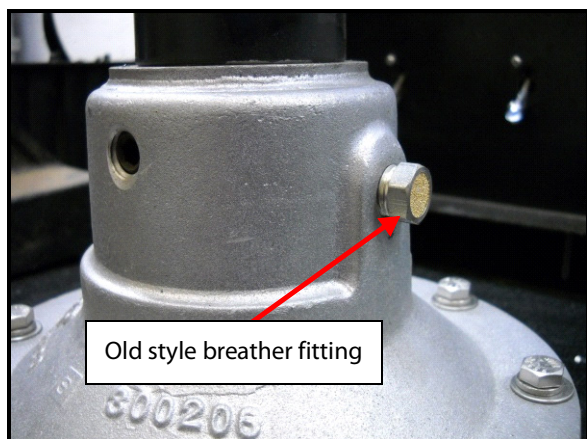

4. Check all mounting bolts for damage and security.
5. Check base plate for damage and leaks.
6. Adjustable deflector ring for cracks and condition.
7. Check for evidence of the diaphragm leaking water.

Repair

Spray Head Replacement

1. Ensure all energy sources are removed from unit to make unit safe for maintenance.
2. Ensure hydraulic pressure is removed from the spray head.
3. Ensure all water has been emptied from tank.
4. Label hydraulic cylinder supply hoses.
5. Remove hydraulic hoses and cap openings.

CAUTION

Ensure all open hydraulic lines are capped to prevent hydraulic system contamination. Contamination may cause damage to hydraulic system and components.

6. Remove base plate mount bolts and washers.
7. Remove spray head.
8. Inspect base plate for damage and water pipe for obstructions or debris.
9. Lubricate and install new O-ring on lower housing groove of the spray head.

SECTION 6

Spray System

- Install spray head on base plate with 4 mounting bolts and steel washers.

CAUTION

Ensure bolt threads are coated with Loctite® Marine grade anti-seize or equivalent prior to reassembly. Failure to ensure threads are coated may result in damage to fastener or thread bores when repair or replacement becomes necessary.

- Tighten mounting bolts.
- Reconnect labeled supply hoses.
- Pressurize hydraulic spray system and check for leaks as well as proper spray head operation.

Hydraulic Cylinder Replacement

- Ensure all energy sources are removed from unit to make unit safe for maintenance.
- Ensure hydraulic pressure is removed from the spray head.
- Ensure all water has been emptied from tank.
- Label hydraulic cylinder supply hoses.
- Remove hydraulic hoses and cap openings.

CAUTION

Ensure all open hydraulic lines are capped to prevent hydraulic system contamination. Contamination may cause damage to hydraulic system and components.

- Remove hydraulic cylinder by turning the entire cylinder counter-clockwise (CCW).

- Install two 1/2-20 nuts on new hydraulic cylinder rod. Ensure the cylinder is fully extended by carefully applying air to the CLOSE port at the top of the cylinder.

CAUTION

Ensure bolt threads are coated with Loctite® Marine grade anti-seize (34395) or equivalent prior to reassembly. Failure to ensure threads are coated may result in damage to fastener or thread bores when repair or replacement becomes necessary.

- Measure distance "X" from the top of upper housing to the top of the diaphragm bolt head as shown below.

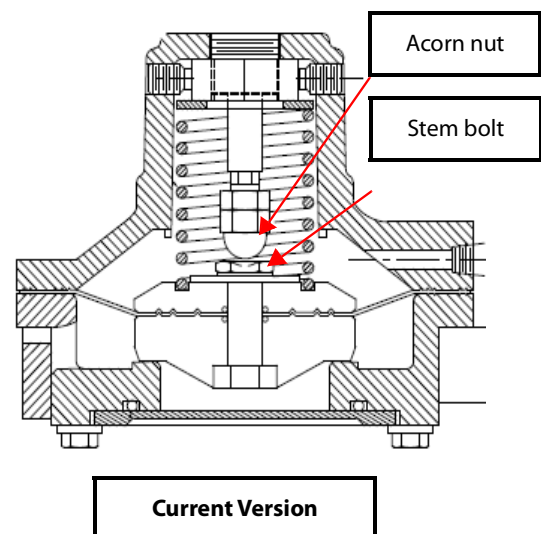
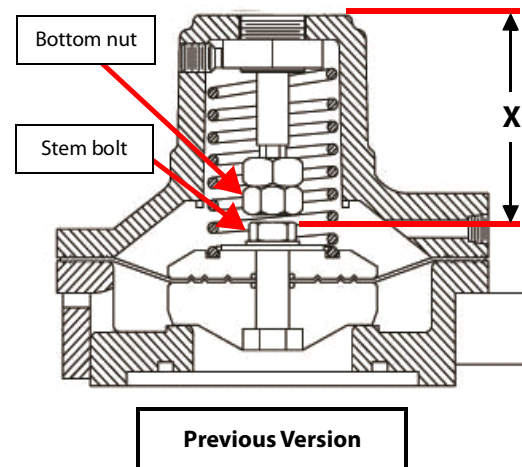

SECTION 6 Spray System

9. **(Previous version only)** With the cylinder fully extended adjust bottom nut 1/16" (1.59 mm) longer than dimension X to create proper diaphragm preload as shown below. Tighten upper jam nut.

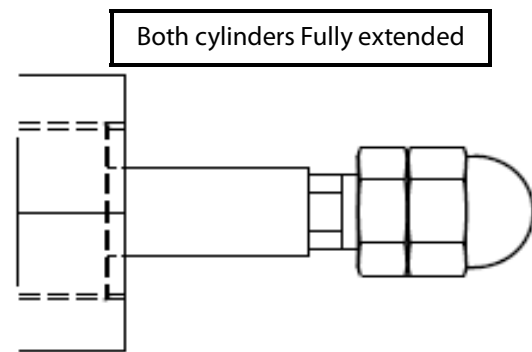
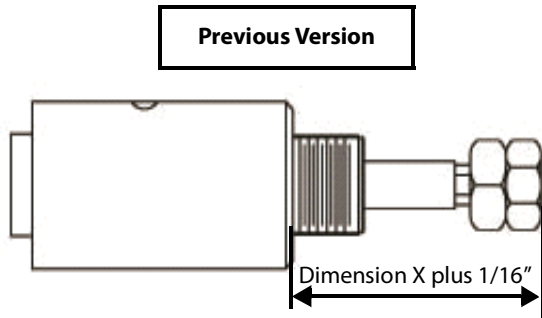

Current Version

10. **(Current version only)** Bottom acorn nut out on the Cylinder rod. Tighten jam nut against the acorn nut.

NOTE

The acorn nut (current version) is only used with a divot stem bolt. The flat nut (previous version) is compatible with both a flat or divot stem bolt.

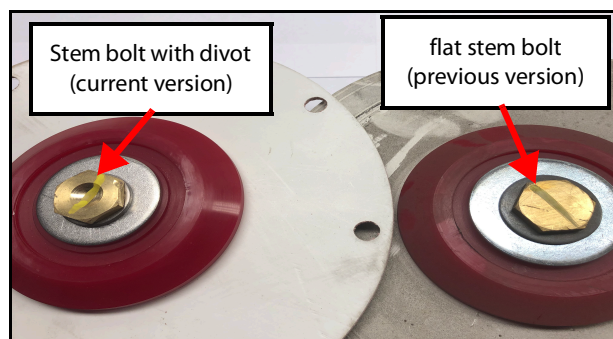

11. Install new hydraulic cylinder on upper housing and tighten.

CAUTION

Ensure cylinder threads are coated with Loctite® Marine grade anti-seize (34395) or equivalent prior to reassembly. Failure to ensure threads are coated may result in damage to fastener or thread bores when repair or replacement becomes necessary.

12. Seal and install hydraulic fittings.
13. Reconnect labeled supply hoses.
14. Pressurize hydraulic spray system and check for leaks as well as proper spray head operation.

Drop-in Assembly Build-up

1. Perform the assembly stack-up sequence as follows:
 - a. Nut.
 - b. Lower guide disk.
 - c. O-ring.
 - d. Diaphragm.
 - e. O-ring.
 - f. Upper guide disk.
 - g. Flat washer
 - h. Lock washer
 - i. Bolt stem

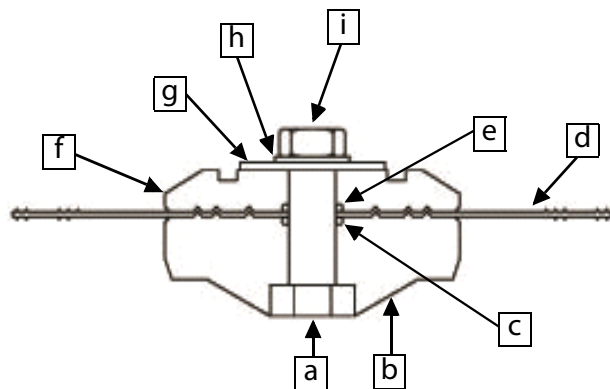

2. Torque bolt stem (i) 18-20 ft-lbs (24-27 nm).

SECTION 6

Spray System

Drop-in Assembly Replacement

1. Ensure all energy sources are removed from unit to make unit safe for maintenance.
2. Ensure hydraulic pressure is removed from the spray head.
3. Ensure all water has been emptied from tank.
4. Label hydraulic cylinder supply hoses.
5. Remove and cap hydraulic hoses.
6. Remove spray head from base plate.
7. Remove upper housing mount bolts and upper housing.

NOTE

Push down on upper housing while loosening mount bolts. There is a compressed coil spring inside of the housing.

8. Remove old drop-in assembly.
9. Inspect lower housing for cracks, condition.
10. Remove any obstructions or debris from the bottom of the lower housing.
11. Inspect upper housing for crack and condition.
12. Inspect spring for damage and condition.
13. Install new drop-in diaphragm with upper guide disk facing up.
14. Position upper housing assembly over the new drop-in assembly.

15. Hold down upper housing and install mount bolts with washers. Torque mount bolts evenly to 10-12 ft-lbs (14–16 Nm).

CAUTION

Ensure bolt threads are coated with Loctite® Marine grade anti-seize (34395) or equivalent prior to reassembly. Failure to ensure threads are coated may result in damage to fastener or thread bores when repair or replacement becomes necessary.

16. Pressurize hydraulic spray system and check for leaks as well as proper spray head operation.

Spring Replacement

1. Ensure all energy sources are removed from unit to make unit safe for maintenance.
2. Ensure hydraulic pressure is removed from the spray head.
3. Ensure all water has been emptied from tank.
4. Label hydraulic cylinder supply hoses.
5. Remove and cap hydraulic hoses.
6. Remove spray head from base plate.
7. Remove upper housing mount bolts and upper housing.

NOTE

Push down on upper housing while loosening mount bolts due to a compressed coil spring inside of the housing.

SECTION 6

Spray System

8. Remove spring.

NOTE

Some springs may have the upper housing nut set screw inserted between spring coils. The set screws must be removed to release the spring assembly.

9. Inspect upper housing for cracks and condition.
10. Inspect lower housing for cracks and condition.
11. Inspect drop-in assembly diaphragm for holes, cuts and condition.
12. Inspect upper and lower guide disks for damage and condition.
13. Install spring assembly.
14. Position upper housing assembly over the new drop-in assembly.
15. Hold down upper housing and install mount bolts with washers. Torque mount bolts evenly to 10-12 ft-lbs (14-16 Nm).

CAUTION

Ensure bolt threads are coated with Loctite® Marine grade anti-seize or equivalent prior to reassembly. Failure to ensure threads are coated may result in damage to fastener or thread bores when repair or replacement becomes necessary.

16. Install new spray head base O-ring.
17. Install spray head on base plate.
18. Install and secure hoses to labeled cylinder ports.
19. Pressurize hydraulic spray system and check for leaks as well as proper spray head operation.

Upper Housing Breather Port

1. Ensure all energy sources are removed from unit to make unit safe for maintenance.
2. Ensure hydraulic pressure is removed from the spray head.
3. Ensure all water has been emptied from tank.
4. Label hydraulic cylinder supply hoses.
5. Remove and cap hydraulic hoses.
6. Remove spray head from base plate.
7. Remove breather from upper spray head housing (if equipped).

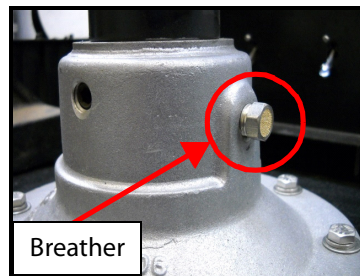

8. Ensure upper spray head housing does not contain water or debris. Repair as required.
9. Install vent tube fitting: 1-1/4" NPT X 3/8" Tube fitting in hole (MEGA Part number 351082) and angle down as shown below.



351082 - 1/4" NPT X 3/8" tube
90° compression fitting

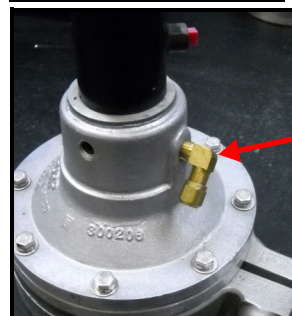

Vent tube fitting

SECTION 6

Spray System

10. Install a length of $\frac{3}{8}$ " tube 8" (200 mm) long into compression fitting and secure nut as shown below.

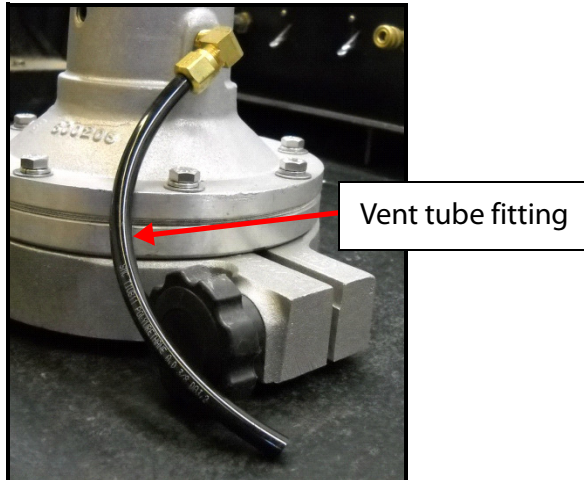

11. Ensure the vent tube is not in the path of the outlet of the spray head.
12. Install new spray head base O-ring.
13. Install spray head on base plate.
14. Install and secure hoses to labeled cylinder ports.
15. Pressurize hydraulic spray system and check for leaks as well as proper spray head operation.

If your system is not covered in this manual or are having problems please contact MEGA Corp. Product Support Group at:

US toll free: 1-800-345-8889
Direct: 1-505-345-2661

Or visit our website at www.megacorpinc.com for more detailed contact information.

PNEUMATIC SPRAY HEAD

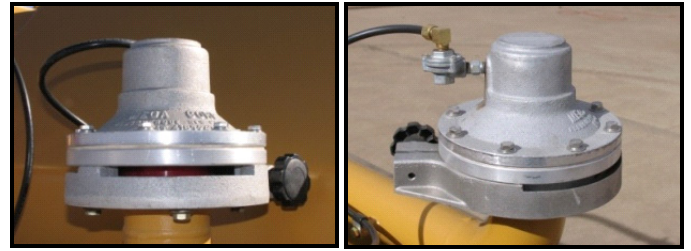

A two piece aluminum valve body and adjustable ring mounted to a water supply header pipe. The upper portion of the valve body is an air chamber with a diaphragm and guide disk assembly attached to the bottom. The air chamber receives pressurized air from the solenoid control box as commanded by the cab control switch. When the upper portion of the valve body is pressurized the guide disk will seal the opening on the lower portion of the valve and stop water flow.

When the cab control system is OFF and the water pump is OFF the air chamber incorporates a spring that will apply pressure to the guide disk assembly and seal the opening on the lower portion of the valve and stop flow. When air pressure is removed from the upper portion of the valve body when the water pump is ON and the cab control switch ON, pressurized water from the spray bar will unseat the guide disk and water will flow from the lower portion of valve.

Inspection

1. Check the regulated air pressure for proper pressure setting.

CAUTION

The water pressure dictates the air pressure required to close the pneumatic spray head. If the air pressure is too high, it can cause shortened service life on the guide disk and diaphragm components or potentially cause a water hammer situation. Ensure the regulated air pressure is set 5-10 psi (34-69 kpa) maximum above the high idle water pressure reading [e.g: water pressure = 75 psi (520 kpa) at high idle, regulated air pressure must be adjusted to and set at 80-85 psi (550-585 kpa)].

SECTION 6

Spray System

2. Inspect relief valve and hose for leaks and security.
3. Upper and lower housings for cracks, damage or evidence of water leaks.
4. All mounting bolts for damage and security.
5. Base plate for damage and leaks.
6. Adjustable deflector ring for cracks and condition.
7. Evidence of the diaphragm leaking water.

Repair

Spray Head Replacement

1. Ensure pneumatic and water pressure is removed from the spray head.
2. Ensure the water tanker is empty before performing this service.

NOTE

If water level in tanker is higher than the spray head base plate, water will come out of the spray bar when the spray head is removed.

3. Label pneumatic supply hose and disconnect.
4. Plug pneumatic hose.

NOTE

Ensure open pneumatic lines are capped to prevent system contamination.

5. Remove base plate mount bolts.
6. Remove spray head.
7. Inspect base plate for damage and water pipe for obstructions or debris.

8. Install new O-ring on lower housing of the spray head and install spray head with 4 mounting bolts and steel washers.
9. Tighten mounting bolts.

CAUTION

Ensure bolt threads are coated with Loctite® Marine grade anti-seize or equivalent prior to reassembly. Failure to ensure threads are coated may result in damage to fastener or thread bores when repair or replacement becomes necessary.

10. Reconnect labeled supply hose.
11. Pressurize pneumatic spray system and check for leaks as well as proper spray head operation.

Drop-in Assembly Build-up

1. Perform the assembly stack-up sequence as shown below.

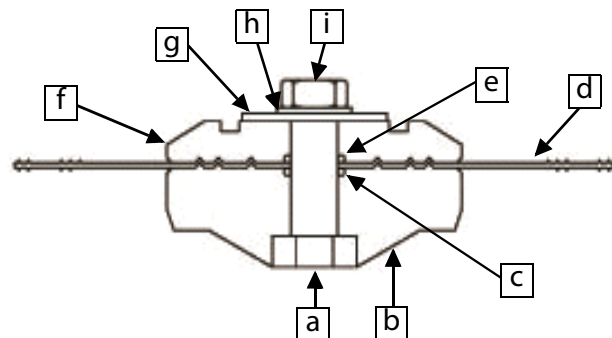

- a. Nut.
- b. Lower guide disk.
- c. O-ring.
- d. Diaphragm.
- e. O-ring.
- f. Upper guide disk.
- g. Flat washer
- h. Lock washer
- i. Bolt stem

2. Torque bolt stem (i) 18-20 ft-lbs (24-27 Nm).

SECTION 6

Spray System

Drop-in Assembly Replacement

1. Remove upper housing mount bolts and upper housing.

NOTE

Push down on upper housing while loosening mount bolts. There is a compressed coil spring inside of the housing.

2. Remove old drop-in assembly.
3. Inspect lower housing for cracks, condition.
4. Remove any obstructions or debris from the bottom of the lower housing.
5. Inspect upper housing for crack and condition.
6. Inspect spring for damage, condition and weak compression.
7. Install new drop-in assembly with upper guide disk facing up.
8. Position coil spring on upper guide disk.
9. Position upper housing assembly over the new drop-in assembly.
10. Hold down upper housing and install mount bolts with washers. Torque mount bolts evenly to 10-12 ft-lbs (14-16 Nm).

CAUTION

Ensure bolt threads are coated with Loctite® Marine grade anti-seize or equivalent prior to reassembly. Failure to ensure threads are coated may result in damage to fastener or thread bores when repair or replacement becomes necessary.

11. Pressurize pneumatic spray system and check for leaks as well as proper spray head operation.

Spring Replacement

1. Remove upper housing mount bolts and upper housing.

NOTE

Push down on upper housing while loosening mount bolts. There is a compressed coil spring inside of the housing.

2. Remove spring.
3. Inspect upper housing for cracks and condition.
4. Inspect lower housing for cracks and condition.
5. Inspect drop-in assembly diaphragm for holes, cuts and condition.
6. Inspect upper and lower guide disks for damage and condition.
7. Install spring assembly.
8. Position upper housing assembly over the new drop-in assembly.
9. Hold down upper housing and install mount bolts with washers. Torque mount bolts evenly to 10-12 ft-lbs (14-16 Nm).

CAUTION

Ensure bolt threads are coated with Loctite® Marine grade anti-seize or equivalent prior to reassembly. Failure to ensure threads are coated may result in damage to fastener or thread bores when repair or replacement becomes necessary.

10. Pressurize pneumatic spray system and check for leaks as well as proper spray head operation.

SECTION 6

Spray System

HYDRAULIC CONTROL BOX



Description

The assembly contains hydraulic solenoid control valves that direct hydraulic pressure to spray heads and BFV assemblies. The assembly receives hydraulic pressure from the water pump hydraulic circuit and delivers return oil to the low pressure tank return circuit. Solenoid valves receive command signals from cab control box to open or close the respective spray head or BFV. The solenoid control box also provides for spray head system over pressurization protection. The assembly is protected by a hydraulic oil filter typically mounted to the control box.

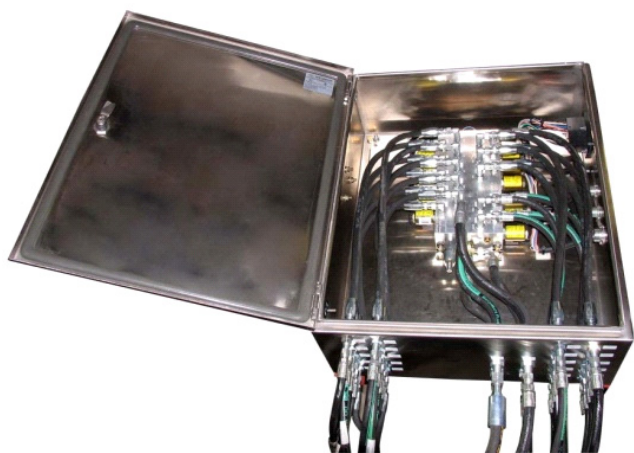

Inspection

1. Inspect box for damage, leaks and security.
2. Inspect hosing and fittings for security, leaks and condition.
3. Wire harness so security, damage and condition.
4. Remove box access cover and inspect components for the following:
 - a. Solenoid valves and wiring for security, leaks and condition.
 - b. Manifold assemblies for security, leaks and cracks.
 - c. All fittings and hoses for security and leaks.
 - d. Pressure reduction manifold for security and leaks.
 - e. Wire terminals and wiring for security and damage.

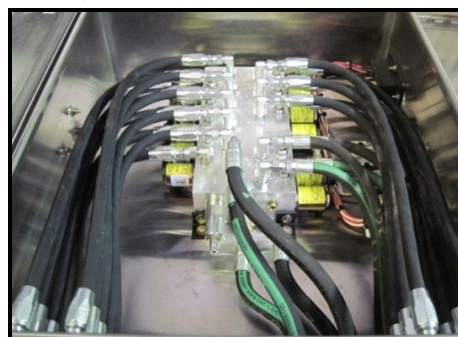

Typical front bulkhead mounted hydraulic control box

5. Check control box hydraulic filter minder for restriction with engine running. If **GREEN**, then the system is OK. If filter minder is **RED**, then filter service is required.

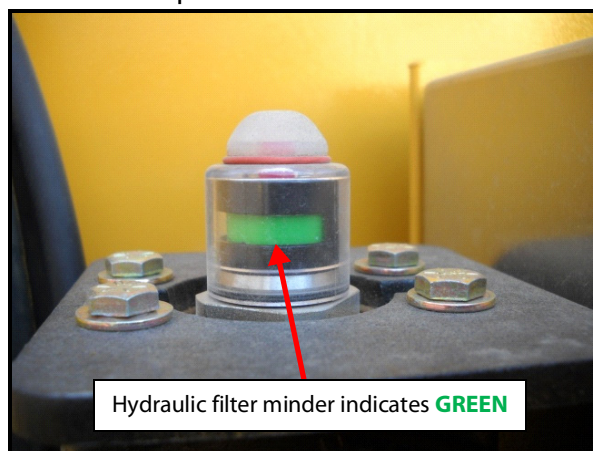

Hydraulic filter minder indicates **GREEN**

SECTION 6 Spray System

Repair

Hydraulic Oil Filter

1. Check control box hydraulic filter minder for restriction with engine running. If **GREEN**, then the system is OK.

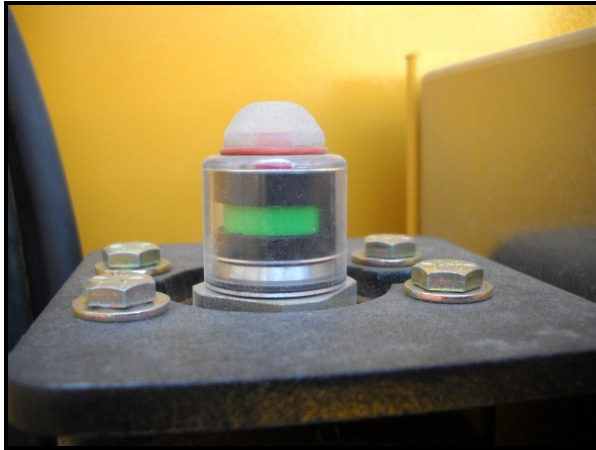

2. If filter minder is **RED**, then filter service is required.
3. Service/clean hydraulic filter as follows and as illustrated on following page:
 - a. Remove hydraulic pressure from control system, make unit safe for service.
 - b. Properly drain and dispose of oil from filter housing.
 - c. Remove filter element from housing and follow cleaning instructions as described below.
 1. Remove external build-up of contamination with cleaning fluid in separate tank.

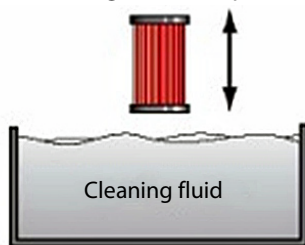

2. Remove large particles in the pleats using a rounded needle or tweezers.

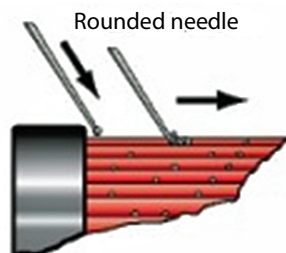

3. Immerse the element for 30 minutes in high quality cleaning fluid.



4. Flush from the inside with air-water pistol.

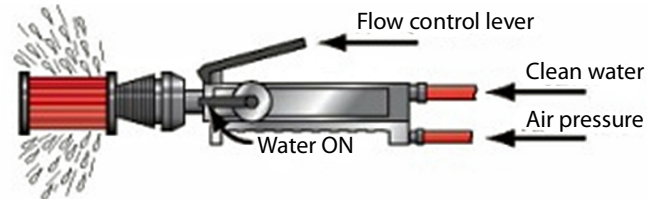

5. Turn off water and blow from inside with air only.

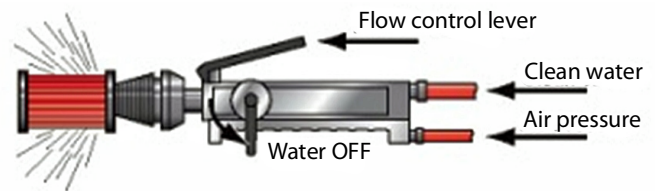

6. Immerse in isopropyl alcohol to remove the remaining water particles.



7. Allow element to dry. Then pack element in air-tight plastic bag for future use.

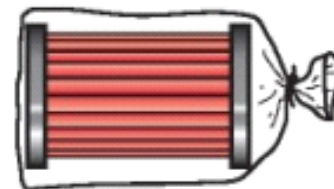

4. Re-install cleaned filter element or install new filter element in filter head, ensure to lubricate new O-ring with clean system fluid.

5. Use twisting motion to prevent O-ring damage when installing filter element.

SECTION 6 Spray System

6. Screw filter housing into filter head.

CAUTION

Do not torque filter housing in filter head, hand tighten only. Over-torquing filter housing will result in damage to O-rings, filter head and filter housing.

7. Pressurize system and check for leaks.
8. Ensure filter minder indicator is **GREEN**.

CAUTION

If you are having trouble understanding the procedure contained in this document, immediately contact the MEGA Corp. Product Support Group at:

US Toll free: 1-800-345-8889

Direct: 1-505-345-2661

Or visit our website at www.megacorpinc.com for more detailed contact information.

Coil Replacement

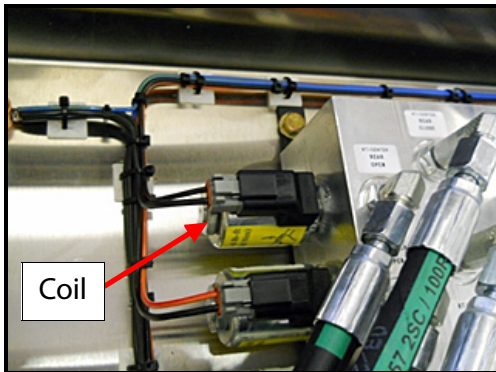

1. Remove all hydraulic pressure from the vehicle hydraulic system.
2. Remove all electrical power from the spray system.
3. Open solenoid control box cover and mark coil wire locations.
4. Remove wiring from solenoid.

5. Remove old coil and install new coil. Torque coil/solenoid retaining nut to 4-6 ft lbs. (6 – 8 nm).
6. Attach new coil wires to the previously labeled locations.
7. Secure wiring harness.
8. Perform full functional check of the spray system component replaced.
9. Close solenoid control box cover.

Solenoid Valve Cartridge Replacement

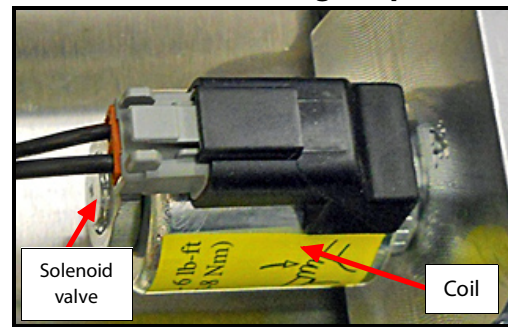

1. Remove all hydraulic pressure from the vehicle hydraulic system.
2. Remove all electrical power from the spray system.
3. Open solenoid control box cover and mark coil wire locations.
4. Remove coil.
5. Remove solenoid cartridge from hydraulic manifold.
6. Lubricate O-rings on new solenoid cartridge.
7. Install new solenoid cartridge with O-rings into manifold.
8. Reinstall coil and torque retaining nut to 4 - 6 ft lbs. (6-8 nm).
9. Apply hydraulic pressure to the spray system and check solenoid valve for leaks.

SECTION 6

Spray System

10. Perform full functional check of the spray system component replaced.
11. Close solenoid control box cover.
12. Service vehicle hydraulic system as required.
7. Install in-line pressure gauge on one of the spray head close port to observe system pressure for adjustment of the pressure reducing valve.
8. Loosen pressure reducing valve jam nut and insert Allen wrench in the pressure reducer adjustment stem.

Pressure Reducing Valve Replacement

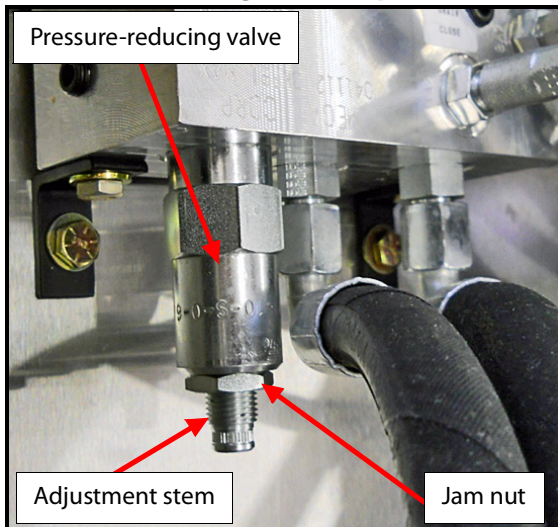

1. Remove all hydraulic pressure from the vehicle hydraulic system.
2. Remove all electrical power from the spray system.
3. Open solenoid control box cover to gain access to pressure reducing valve.
4. Remove old pressure reducing valve.
5. Lubricate new pressure relief valve.
6. Install new pressure reducing valve.
9. Apply hydraulic and electrical power to the spray system.
10. Note system pressure at gauge.
11. Adjust pressure reducing valve stem to set 550 PSI (3,800 kpa). Tighten jam nut.
12. Perform full operation check of all hydraulic spray system functions.
13. Close solenoid box cover.
14. Shutdown spray system and service vehicle hydraulic system as required.
15. Remove hydraulic pressure gauge from spray head and reconnect hydraulic hose.

CAUTION

Pressure relief must be set to no more than 550 PSI (3,800 kpa). Higher pressure settings will allow spray heads to open and close rapidly and cause water hammering of the water pump system. Continued water hammering will cause damage to water pump system.

SECTION 6 Spray System

PNEUMATIC SOLENOID CONTROL BOX

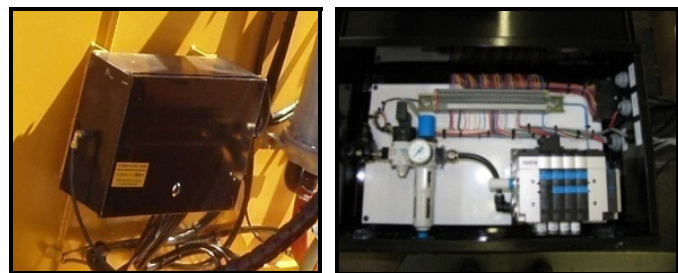

The control box assembly is mounted to the tank front bulkhead and controls spray functions as commanded by the cab control box. The assembly contains pressure protection valve, shut-off valve/pressure regulator, pneumatic solenoid valve bank and wire terminal. The solenoids and shut-off valves receive pneumatic pressure from the vehicle and 24 VDC power from the cab control box.

Solenoid valves receive command signals from cab control box to open or close the respective spray head or BFV. The solenoid control box also provides for spray head system over pressurization protection.

Inspection

1. Inspect box for damage, leaks and security.
2. Inspect hosing and fittings for security, leaks and condition.
3. Wire harness for security, damage and condition.
4. Open solenoid box access cover and inspect components for the following:
 - a. Solenoid valves for security, leaks and condition.
 - b. Pneumatic regulator valve for security, leaks and condition. Drain regulator bowl.
 - c. Pneumatic shut-off valve for security, leaks and condition.
 - d. Pneumatic pressure protection valve for security, leaks and condition.
 - e. All fittings and hoses for security and leaks
 - f. Wire terminals and wiring for security and damage.
5. Check control box air pressure regulator water separator and filter to ensure filter is clean and no water is present.

Parts Identification

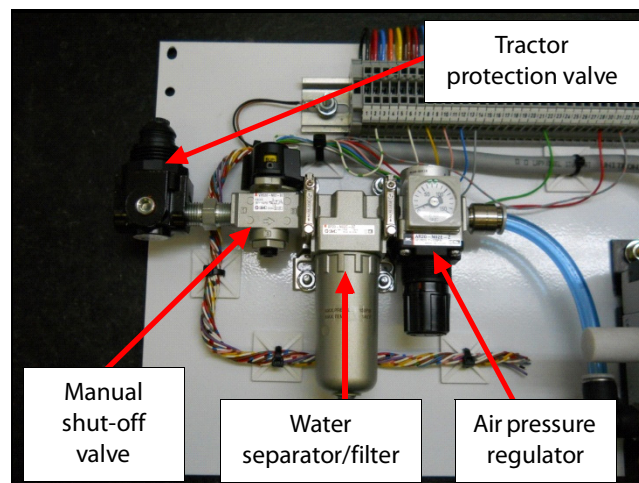
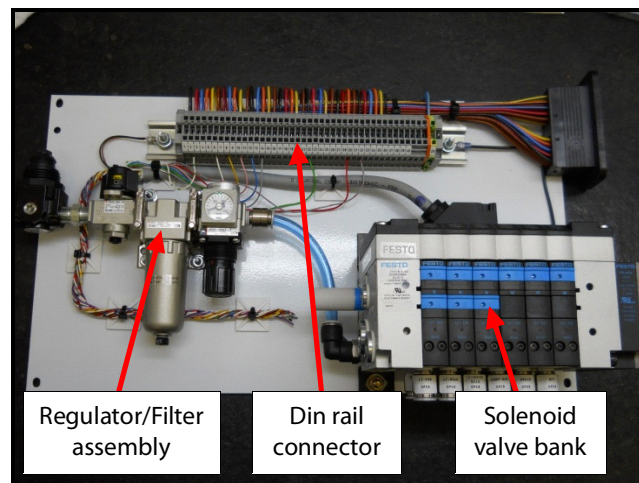
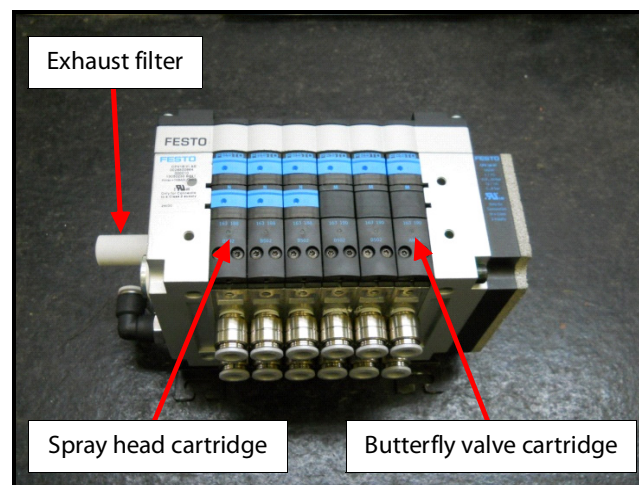

SECTION 6 Spray System

Parts Identification (Continued)

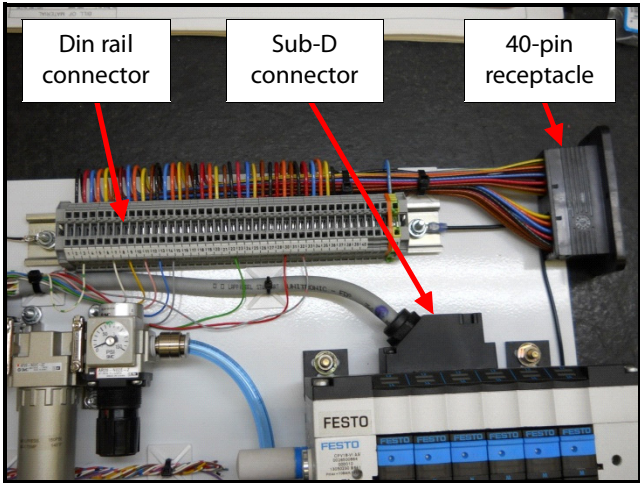

Repair Replacement of Solenoid Valve Cartridge

1. Remove and isolate all energy sources on unit, make unit safe for maintenance.
2. Ensure air supply to solenoid valve bank is OFF.
3. Mark and identify all air tubing and fittings at solenoid valve bank.
4. Push tubing retaining ring toward fitting and pull hose from fitting.

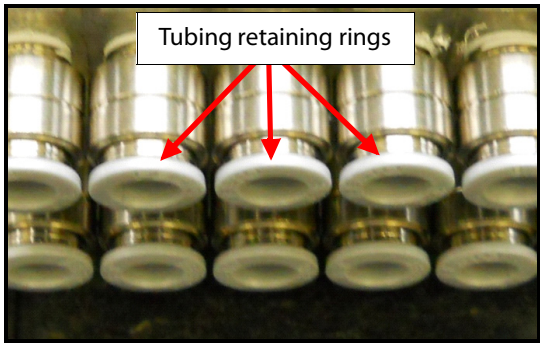

5. Remove Sub-D connector from top of valve bank.

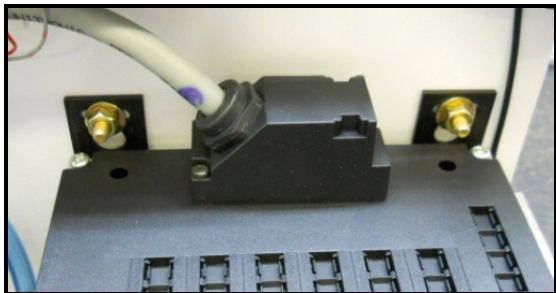

6. Remove 4 mounting bolts for valve bank to plate.



7. Remove valve bank grounding wire.



8. Remove 4 screws from top of valve bank, releasing Sub-D connection/valve electrical connection plate. Remove plate.



9. Remove gasket from top of valve bank.

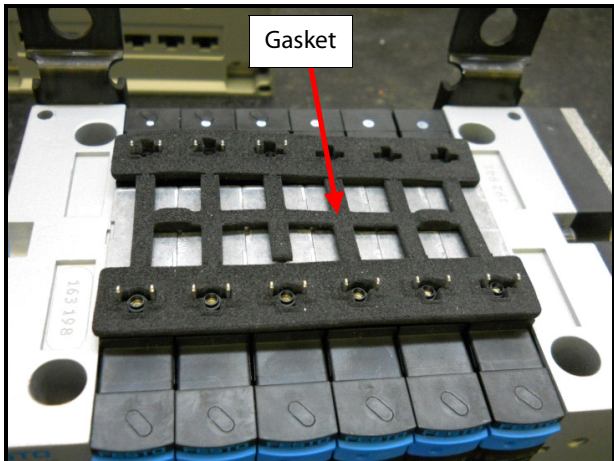

SECTION 6

Spray System

10. Remove 3 Allen head bolts from valve bank, releasing end plate and valve cartridges.

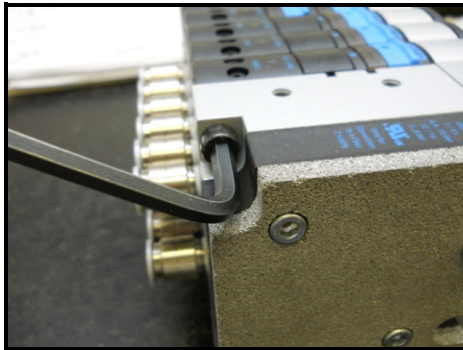

11. Separate valve cartridges.

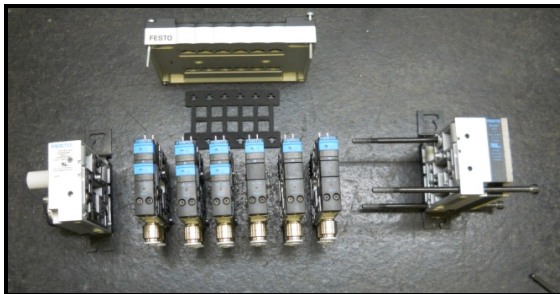

12. Replace defective cartridge. Ensure gaskets between cartridges are not damaged and line up with pins on valves.

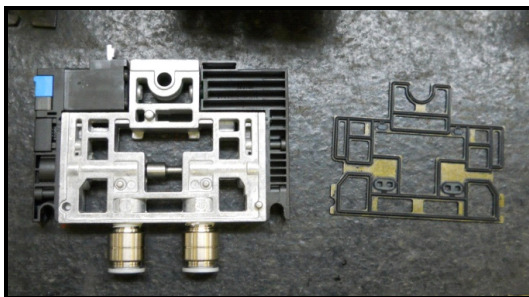

13. Stack valve cartridges together.

14. Align mounting holes, assemble valve bank end plates, tighten 3 Allen head bolts.

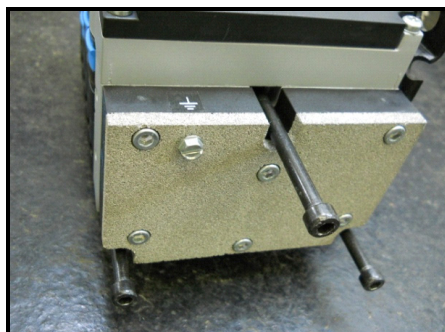

15. Install top plate gasket and top plate, ensure all valve cartridge electrical connectors align with slots of top plate.

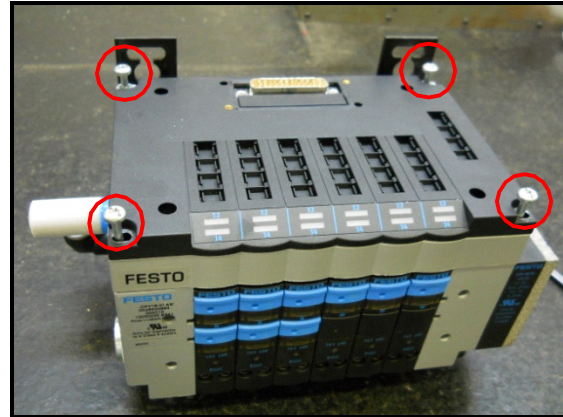

16. Tighten 4 screws.

17. Reconnect grounding wire to ground screw.

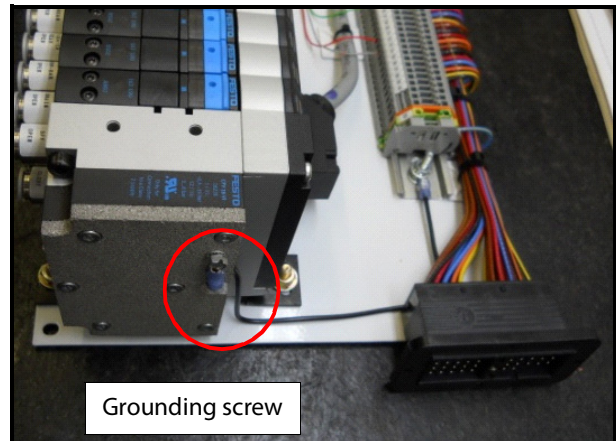

18. Reinstall solenoid valve bank on plate.

19. Reinstall Sub-D connector to top plate.

20. Reconnect air tubing as previously marked.

21. Check and ensure air filter/water separator contains no water or debris.

22. Restore vehicle to operational condition.

23. Perform operational system checks to ensure repair is complete.

SECTION 6 Spray System

Solenoid Valve Indicator Lights

NOTE

When power is removed from control system or solenoid valve, the device (spray head, butterfly valve) will close by allowing air pressure to be diverted to the component or to the CLOSE side activation port of the actuator.

1. Gain access to solenoid control box.
2. Ensure system power is ON.
3. Solenoid valve indicator lights visually indicate which solenoid is activated or deactivated.
4. With all spray head switches in the OFF position, no indicator lights should be illuminated as shown below.

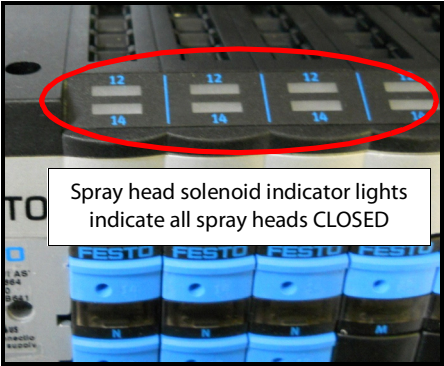

5. Spray head solenoid valve indicator light will illuminate when spray head switch is ON allowing spray head to OPEN.

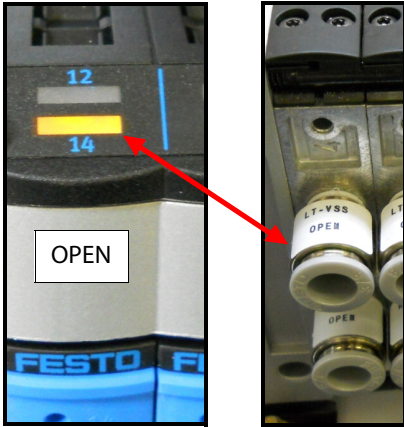

NOTE

Spray head cartridges operate 2 spray heads each.

6. Butterfly valve solenoid valves indicate CLOSE when the light is extinguished as shown below.



SECTION 6 Spray System

- When butterfly valve is commanded to OPEN, the forward light will illuminate indicating air pressure is diverted to the OPEN side of the actuator as shown below, likewise when the light is extinguished the air pressure is diverted to the CLOSE side of the actuator.



OPEN

NOTE

Butterfly valve cartridges operate only 1 butterfly valve each.

- If indicator lights fail to illuminate, check cab control power to ensure cab control receives 24 VDC and is properly grounded to chassis.
- Check solenoid control box grounds to ensure grounds are intact and in good condition as shown below.

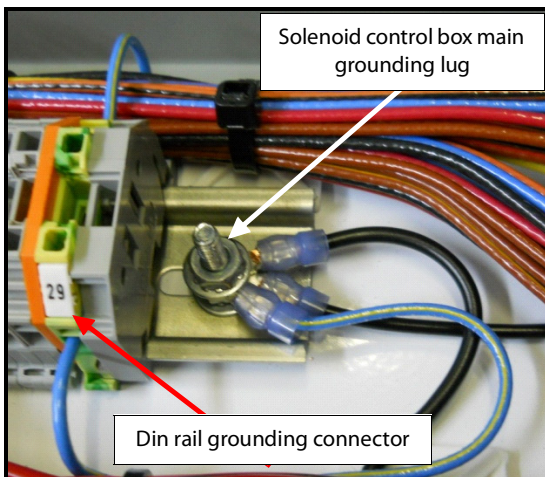

- Inspect all electrical wiring harness connectors for possible damage or disconnection, ensure all sealing gaskets are in place and in proper position and connectors are tight.
- Inspect wiring harness for damage.
- Check tank grounding strap to chassis to ensure proper grounding of tank.

Solenoid Valve Replacement

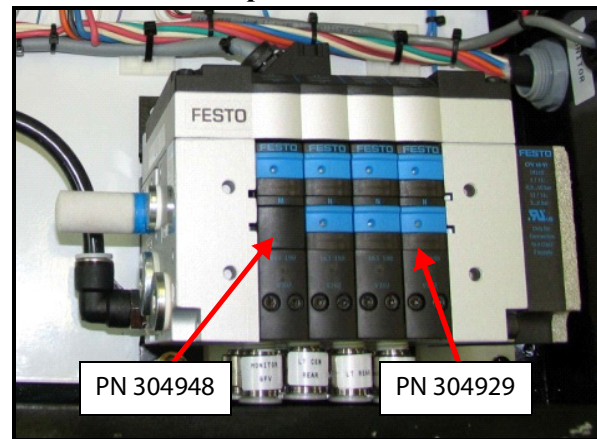

- Ensure pneumatic pressure and electric power is removed from the solenoid box.
- Disconnect the Sub-D connector from the top of the solenoid bank as shown below.
- Disconnect the solenoid bank pneumatic supply hose as shown below.
- Remove entire solenoid bank from the mounting plate as shown below.
- Label each solenoid valve section before disassembly.
- Remove 4 mounting screws from the solenoid bank cover as shown below. Remove cover and foam gasket from the top of the solenoid bank.
- Remove the 3 side mount bolts as shown below.

SECTION 6

Spray System

8. Remove the malfunctioning solenoid and replace with serviceable solenoid.
9. Reinstall 3 side mount bolts.
10. Reinstall solenoid bank foam gasket and top cover. Secure the cover 4 mount screws.
11. Reinstall solenoid bank on mounting plate and secure mounting bolts.
12. Reconnect the pneumatic supply hose.
13. Reconnect the Sub-D connector to the top of the solenoid bank.
14. Pressurize pneumatic spray system, check for leaks as well as proper spray head operation.
3. Remove 90 degree brass elbow from the pneumatic supply hose left of the assembly.
4. Disconnect the power cable attached to the top of the shut-off valve.
5. Remove the 4 mount screws securing the assembly to the mounting plate.
6. Remove the assembly.
7. Reconfigure new assembly.
8. Install new assembly and secure with 4 mounting screws to the mounting plate.
9. Reattach the shut-off valve power cable.
10. Reconnect the pneumatic supply hoses to the pressure regulator.
11. Pressurize pneumatic spray system, check for leaks as well as proper spray head operation.

NOTE

Ensure the correct solenoid part number is used to replace malfunctioning solenoid (spray head valve #304929 versus the BFV #304948). Additionally, check to ensure the new solenoid is located in the correct position within the solenoid bank stack-up.

Shut-off/Pressure Regulator Assembly



1. Ensure pneumatic pressure and electric power is removed from the solenoid box.
2. Disconnect the pneumatic supply from the right side of the regulator.

PNEUMATIC BUTTERFLY VALVE (BFV) ASSEMBLY

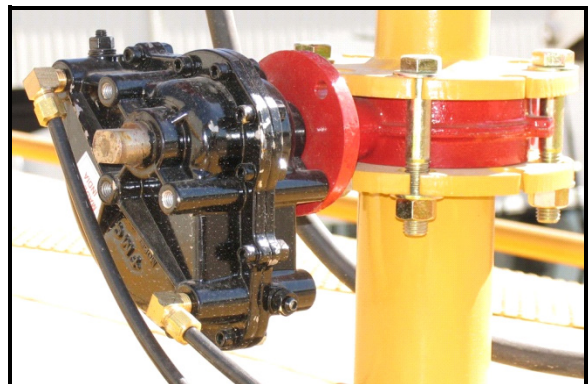

Description

A pneumatically operated valve that opens or closes to control water flow to the water cannon, dump bars, tank drain or quick drain operations. The pneumatic valve receives air pressure from the pneumatic solenoid control box typically mounted on the MST/MSC gooseneck or the MAC/MTT forward bulkhead. Valve sizes range from 3 inch to 5 inch.

SECTION 6

Spray System

Inspection

1. Inspect BFV assembly and hosing for security and leaks.
2. Pneumatic supply hose for damage and leaks.

Repair

BFV Removal

1. Ensure vehicle pneumatic and water pump system is not in operation.
2. Label and disconnect pneumatic supply hoses from BFV pneumatic valve and cap hoses.
3. Remove pipe flange clamping bolts.
4. Remove BFV assembly.

BFV Installation

1. Position BFV between the water pipe flanges and install clamping bolts.
2. Tighten clamping bolts equally to secure BFV between pipe flanges.
3. Reconnect pneumatic supply hoses as previously labeled.
4. Pressurize pneumatic spray system, check for leaks as well as proper component operation.

BFV Disassembly/Inspection & Reassembly

1. Mark BFV orientation to the pneumatic valve before removal to ensure valve operates properly after reinstallation.
2. Remove 3 mount bolts holding the BFV to the pneumatic actuator.
3. Inspect pneumatic valve for obvious damage or pneumatic leaks.
4. Inspect BFV rubber seal for damage, cuts and condition at the valve and both flange sides. If excessive wear is noted replace the BFV.

5. Inspect BFV shaft for damage or evidence of misalignment. If shaft appears to be twisted or misaligned replace the BFV.
6. Position BFV on the pneumatic valve as previously labeled.
7. Torque BFV mount bolts to standard torque value.
8. Pressurize pneumatic spray system, check for leaks as well as proper component operation.

DUMP BAR (IF EQUIPPED)



Description

A dump bar is typically suspended from the rear section of the unit. Water flow to the dump bar is controlled by a BFV that is operated by the control system. Dump bars are configured as a gravity dump bar that receives water from the tank sump. Gravity dump bars are equipped 2 rows of 3/8 in. holes and an internal distribution baffle to evenly distribute water to the entire length of the bar.

Inspection

1. Inspect BFV assembly and hosing for security, operation and leaks.
2. Inspect dump bar mounting for security and damage.
3. Inspect dump bar end caps for security.
4. Inspect dump bar spray pattern for possible blockage of distribution holes.

SECTION 6

Spray System

Repair

1. Remove all electrical/hydraulic power and make the vehicle safe for maintenance.
2. If a blockage of distribution hole is observed, remove end caps from dump bar.
3. Remove internal distribution baffle from dump bar.
4. Flush out holes in dump bar.
5. Reinstall internal distribution baffle.
6. Reinstall dump bar end caps.
7. Operate dump bar to ensure all holes are free flowing.

QUICK DRAIN (IF EQUIPPED)



Description

A quick drain is typically mounted at the rear of the tank or at the water pump sump. The quick drain is controlled by a BFV that is operated by a manual lever. The quick drain provides a method of quickly draining the contents of the tank. Quick drains size is typically 4 inch.

Inspection

1. Inspect BFV assembly, flanges and hosing for security, operation and leaks.
2. Inspect quick drain assembly for security and damage.

Repair

1. Remove all electrical/hydraulic power and make the vehicle safe for maintenance.
2. Repair as necessary.
3. Fill tank with water.
4. Operate drain to ensure proper operation.

SUCTION LOADING (IF EQUIPPED)

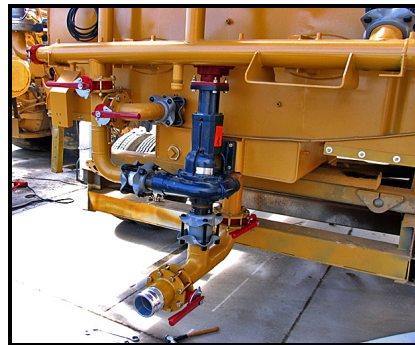

Description

A second water pump mounted typically to the water pump sump at the rear of the MAC/MTT or at the forward bulkhead of the MST/MSC. The suction loading station is equipped with a manual diversion valve that will switch the hydraulic oil flow from the main discharge pump drive motor to the suction loading pump drive motor. When oil is diverted to the suction loading drive motor it can pull water from a holding pond and fill the water tank. The suction loading option includes lengths of 4" suction hose equipped with quick couplers and a check valve inlet foot with a debris screen. The suction hoses are typically stored in tubes either built into the tank or a hanging tube arrangement.

Inspection

1. Inspect hydraulic hosing, diverter valve and drive motor for security, heat build up and leaks.
2. Inspect suction loading pump for security, unusual noises, damage and leaks.
3. Inspect quick couplings and suction hoses for damage and leaks.

SECTION 6

Spray System

4. Inspect suction loading station mounting for security and damage.

Repair

1. Remove all electrical/hydraulic power and make the vehicle safe for maintenance.
2. If suction loading water pump fails to lift water check for priming of water pump, hydraulic drive motor rotation, and properly coupled suction hoses and check valve operation.
3. Prime water pump through fitting in the top of the pump case.

NOTE

Suction loading water pump may need to be primed prior to operation. Remove large pipe plug at top of pump case, fill with water, apply sealant to plug, reinstall plug in pump case.

4. Ensure diverter valve is positioned to operate suction loading station.
5. Ensure all quick coupling gaskets are in operable condition, replace as necessary.
6. Ensure check valve with in the water pump case and in the suction foot and screen are in operable condition, replace as necessary.
7. Ensure sufficient water in holding pond for remote filling of the water tank.

HYDRAULIC HOSE REEL RETRACT SPEED ADJUSTMENT

1. Ensure unit is safe for operation.
2. Ensure tanks has sufficient water to perform operation (approximately ¼ tank of water capacity).

CAUTION

Do not operate the water pump in a dry sump. Dry operation will result in shaft seal damage.

3. Ensure all spray system switches are OFF.
4. Ensure PARK BRAKE is SET.
5. Start engine.
6. Turn POWER switch ON.
7. Turn PUMP switch ON.

CAUTION

Do not engage/disengage the water pump above LOW IDLE. Engaging/disengaging the water pump above low idle will result in water pump component damage and reduced service life.

8. Turn HOSE REEL switch ON (This switch is only available on the MEGA Digital Spray System Control "DiSC").
9. Unreel a section of hose from hose reel suitable for testing rewind speed.
10. Increase engine idle speed to 1,500 rpm.
11. Loosen flow control jam nuts on both hose reel flow controls.

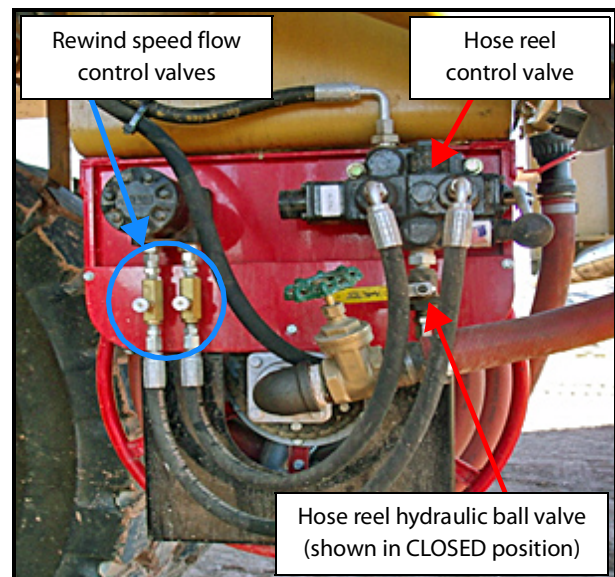

12. Open Hydraulic Rewind hose reel ball valve to allow oil to flow to control valve.

SECTION 6

Spray System

13. Operate control valve lever to retract hose.
14. If increased rewind speed is required or hose fails to retract unscrew (OPEN) both flow control knobs ½ turn.
15. Operate lever, if retract speed is still too slow or hose does not retract, unscrew (OPEN) both flow control knobs by ½ additional turn.
16. Operate lever to rewind hose. If hose reel does not retract or speed is still too slow, contact MEGA product Support Group at US Toll free: 1-800-345-8889 or direct at: 1-505-345-2661 with the water pump drive motor oil pressure, case drain pressure (hose reel return oil pressure), and water pump RPMs for assistance.
17. When desired rewind speed is achieved, lock jam nuts to prevent flow control valve adjustment from changing.
18. Stow hose and turn OFF hose reel ball valve.
19. Reduce engine to LOW IDLE.

CAUTION

Do not engage/disengage the water pump above LOW IDLE. Engaging/disengaging the water pump above low idle will result in water pump component damage and reduced service life.

20. Turn HOSE REEL switch OFF.
21. Turn PUMP switch OFF.
22. Turn POWER switch OFF.
23. Turn ENGINE OFF.

FRONT BUMPER SPRAY BAR



Description

A separate spray bar typically mounted to the front bumper of the chassis. The front bumper spray bar typically receives water pressure from a swivel or nipple mounted on the front bulkhead of the tank. The water is transferred through a flexible hose at the articulation joint of the chassis. A rigid pipe typically mounted to the RH deck of the chassis that transfers the water to the front spray bar. The spray heads are operated from the cab control box that sends an electrical signal to the hydraulic control box and diverts hydraulic oil through hydraulic hosing to the cylinders that operate the spray heads.

Inspection

1. Inspect front bumper spray bar mounting for security and damage.
2. Inspect spray heads for security, operation and leaks.
3. Inspect discharge hosing for security, wear, damage and leaks.
4. Inspect rigid transfer piping for security, damage and leaks.

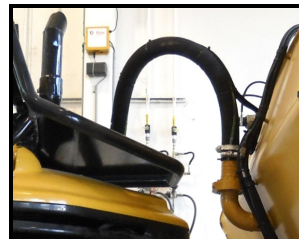

SECTION 6

Spray System

Repair

1. If a water leak is noted, observe the location of the leak.
2. If the water leak is from a spray head repair as required.
3. If a water leak is from a rigid pipe, repair as required.
4. If a water leaks is from a flexible discharge hose, ensure hose clamps are tight and serviceable, repair as required.

NOTE

The discharge hose used in this capacity requires 2 clamps at each end and offset 90° to ensure a quality seal is formed.

5. If a water leak is from the discharge hose, replace hose as required, ensure new clamps are installed when replacing a section of discharge hose.
6. If a hydraulic leak is noted from a hydraulic hose, repair or replace as required.

SECTION 7 Water Cannon System

Contents

Description	7-1	Logic Box (Electric Water Cannon).....	7-4
Inspection	7-2	Hydraulic Control Valve Assembly	7-5
Repair	7-2	Hydraulic BFV	7-9

DESCRIPTION

The system consists of a water cannon, logic box or hydraulic control valve assembly and a BFV. The water cannon directs the water stream as commanded by a joystick that is mounted in the cab control box. These command signals pass through a logic box (electric water cannon) or a hydraulic control valve assembly (hydraulic water cannon) before reaching the water cannon. The system also controls a BFV that opens or closes the water supply for the water cannon. The system may also include an adjustable nozzle. The nozzle is mounted on the water cannon waterway and provides shaping for water stream from fan or fog to straight stream. The nozzles are electrically controlled and hydraulically or electrically actuated through their respective solenoid valve control assembly or logic box. There are also provisions for foam agent education in some nozzle configurations.

CAUTION

- Ensure that the nozzle is stowed in the vertical position when the unit is not operating. Stowing the nozzle in the vertical position will reduce excessive wear on the water cannon joints, gears, and seals. Failure to stow nozzle in vertical position may result in reduced service life and component damage if unit is driven over rough roads.
- Ensure that the water cannon waterway is drained if below freezing temperatures are expected. Lower nozzle to the full lower position and open the butterfly valve until all of the water has drained from water cannon and waterway. If the unit is not operating, leave the nozzle in the full lower position to prevent water from entering the water cannon through the nozzle. Failure to properly drain the water cannon will cause water to freeze in water cannon joints, butterfly valve and waterway causing damage and failure to water cannon system.

Electric Water Cannon



A metal waterway that directs a stream of water in both elevation (up-down) and rotation (right-left). 24 VDC Electric motors move the waterway based upon joystick command signals that are filtered through a logic box. The water cannon also provides mounting for straight bore and adjustable nozzles.

Hydraulic Water Cannon



A metal waterway that directs a stream of water in both elevation (up-down) and rotation (right-left) Joystick commands are routed to the hydraulic control valve assembly that directs oil flow to move hydraulic motors. The water cannon also provides mounting for straight bore and adjustable nozzles.

NOTE

MEGA Water Cannons are shipped clocked to the full LEFT (COUNTER CLOCKWISE) stop and will rotate 95° to the RIGHT (CLOCKWISE).

SECTION 7

Water Cannon System

INSPECTION

1. Water Cannon for security and mounting.
2. Electrical junction box and connections for security and condition.
3. Electric motors for security, condition and evidence of water leakage.
4. Elevation and rotation joints for play and evidence of water leakage.

REPAIR

Remove all electrical/hydraulic power and make the vehicle safe for maintenance.

Electric/Hydraulic Motor Replacement

1. **(Electric only)** Disconnect motor wire harness plug.
2. **(Hydraulic only)** Disconnect hydraulic hoses.
3. Remove 4 mounting bolts from lower motor base plate as shown below.

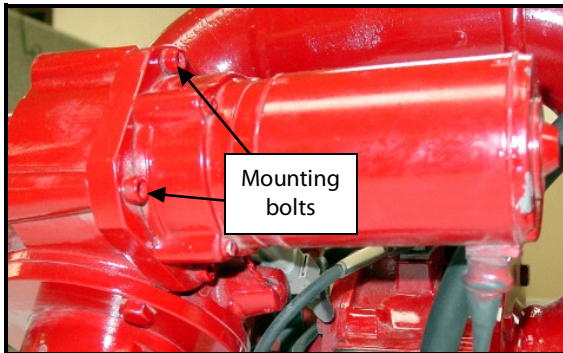

4. Manually rotate the joint to allow worm gear to disengage joint as shown below.



5. Inspect inside joint for evidence of water leakage.
6. Install new motor by rotating the joint to reengage the motor in the joint.
7. Install and tighten mount bolts.
8. **(Electric only)** Connect motor wire harness plug.
9. **(Hydraulic only)** Connect hydraulic hoses.
10. Apply power to the water cannon system and check for proper water cannon operation.

Joint Rebuild

1. Remove electric motor as described in Motor Replacement procedures.
2. **(If equipped)** Remove electrical harness for joint sensor.
3. Remove inner and outer bolt stops as shown below.

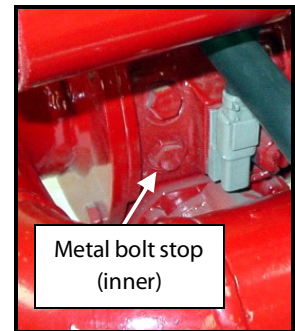
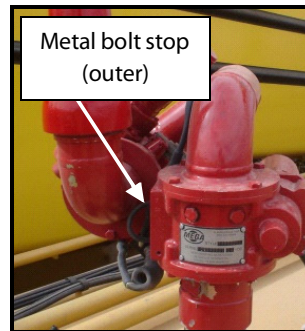

4. Remove joint mount bolts as shown below.



SECTION 7

Water Cannon System

5. Remove joint assembly as shown below.

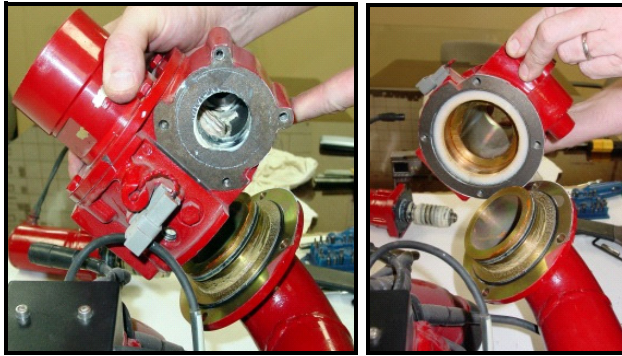

6. Remove lower joint mount bolts and remove worm gear and waterway assembly.

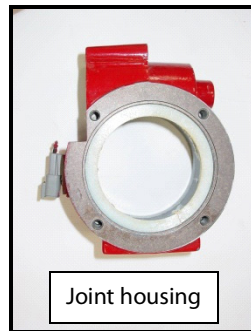

7. Remove poly bearing from joint housing and inspect housing for cracks, corrosion and damage.
8. Disassembly while inspecting worm gear and water way assembly as follows:
- Remove 3 worm gear set screws and remove worm gear as shown below.

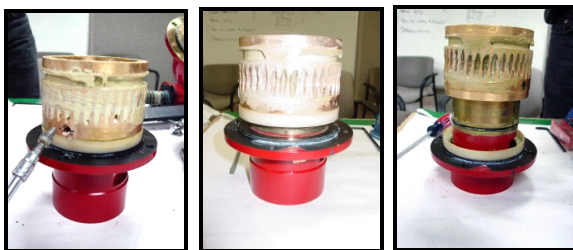

- Remove all o-rings and remaining poly bearing.
 - Inspect worm gear for cracks, wear and condition.
9. Inspect waterway for cracks, corrosion and condition.
10. Repeat steps 1-8 for other joint.

11. Reassemble worm gear and waterway assembly as follows:

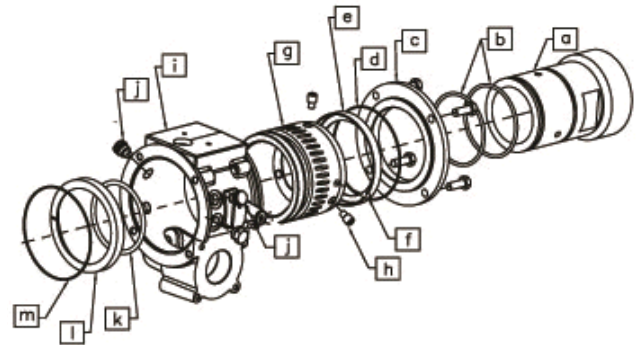

- Waterway.
 - O-rings (2 each).
 - Waterway cap.
 - O-ring.
 - Lower poly bearing.
 - Alignment plug.
 - Worm gear assembly with grease.
 - Install 3 set screws.
 - Joint housing.
 - Rotation/Elevation stop bolt (2 each).
 - Upper poly bearing.
 - O-ring.
12. Install waterway and housing assembly mount bolts.
13. Install motor as described in "Electric/Hydraulic Motor Replacement" on page 7-2.
14. Repeat step 10 for other joint assembly.
15. Once both joints are reassembled and installed apply hydraulic or electrical power to the water cannon and perform a functional check of the water cannon.
16. Check water cannon for full range of travel. Ensure full rotation and elevation of the water cannon and nozzle do not contact any part of the vehicle. If required perform elevation and rotation adjustments of the water cannon.

SECTION 7

Water Cannon System

Water Cannon Stop Adjustment

The water cannon is factory set for 95 degrees of rotation (right to left) and 120 degrees in elevation (up to down).

1. If factory set rotation range (right to left) is not sufficient for your application adjust range of motion as follows:

NOTE

The water cannon stop adjustment can only be accomplished with a fully functional water cannon control system.

a. 30° Rotation Adjustment

1. Rotate water cannon full left and remove plug where shown below:

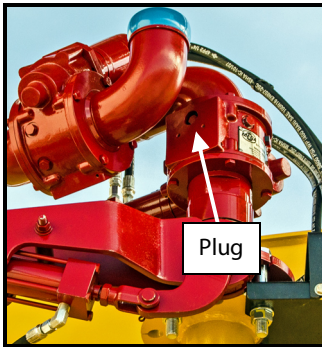

2. Install rotation stop bolt.
3. Operate water cannon through full range of motion to ensure desired range of motion is obtained and water cannon hydraulic hose length is sufficient.

b. 180° Rotation Adjustment

1. Use the joystick/cab control box to position the water cannon full right against mechanical stop.
2. Remove rotation stop bolt as shown below.

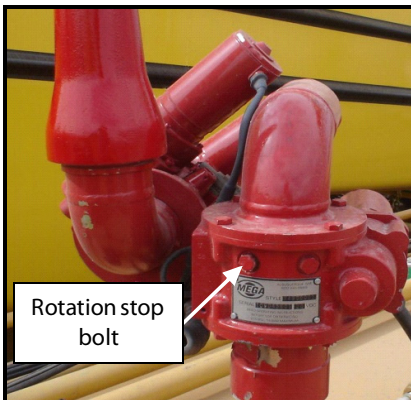

3. Use joystick/cab control box to position water cannon full left against mechanical stop.
4. Reinstall rotation stop bolt.
5. Operate water cannon through full range of motion to ensure desired range of motion is obtained and water cannon hydraulic hose length is sufficient.

c. 320° Rotation Adjustment

1. Remove rotation stop bolt and replace with plastic plug.

CAUTION

Failure to install plastic cap will cause bearing joint failure due to water and dirt ingestion.

2. Operate water cannon through full range of motion to ensure desired range of motion is obtained and water cannon hydraulic hose length is sufficient.
2. After stop adjustment is complete, water cannon final desired position may need to be adjusted by re-indexing water cannon waterway flange.

LOGIC BOX (ELECTRIC WATER CANNON)



Description

An electric controller that provides 24 VDC power to the water cannon system while processing joystick commands to rotate and elevate the water cannon waterway. The controller provides system protection against polarity reversal, undervoltage, overvoltage, feeder fault and excessive current flow. The controller is also capable of providing protection for some electric adjustable nozzles. The logic box is typically mounted under the vehicle jump seat.

SECTION 7

Water Cannon System

Inspection

1. Box for security and mounting.
2. Cables for security, wear and chaffing.

Replacement

1. Raise jump seat or remove protective panel.
2. Release log box from the velcro or remove mounting bolts.
3. Label all 3 Deutsch connectors and disconnect.
4. Install new logic box and secure mount or reattach velcro.
5. Connect labeled Deutsch connectors.
6. Apply power to the water cannon system and perform full functional check.
7. Lower jump seat or install protective panel.

HYDRAULIC CONTROL VALVE ASSEMBLY (HYDRAULIC WATER CANNON)

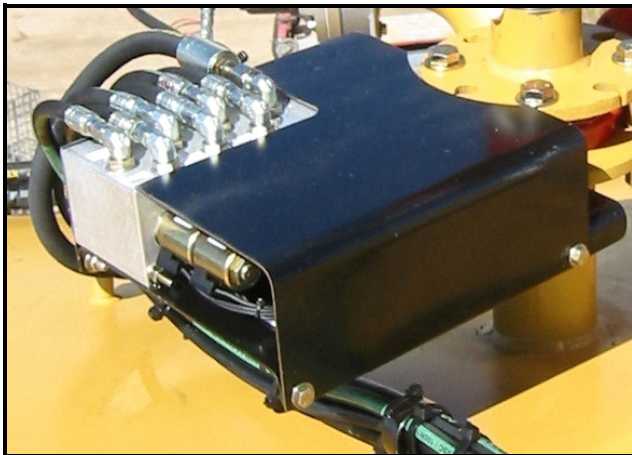

Description

A hydraulic manifold with solenoid valves, coils and a pressure regulator that direct hydraulic pressure to the water cannon hydraulic motors, waterway BFV and hydraulic adjustable nozzle. The assembly receives hydraulic pressure from the water pump drive motor PRESSURE oil circuit or hoist valve pilot oil circuit with return oil routed to the vehicle tank.

Four hydraulic solenoids direct hydraulic pressure to the water cannon hydraulic motors, BFV or hydraulic adjustable nozzle as commanded by the joystick or cab control switches. The assembly also provides for over pressurization protection for the entire water cannon system.

Inspection

1. Assembly and mounting plates for security, condition and leaks.
2. Hosing and adapters for security, leaks and condition.
3. Wiring for security and condition.
4. Solenoids and pressure reducer for security, leaks and condition.

Repair And Adjustment

Coil Replacement

1. Remove all electric and hydraulic power from the water cannon system and make unit safe for maintenance.
2. Remove control valve assembly upper cover to gain access to control components.
3. Mark and remove electrical connector from solenoid coil.

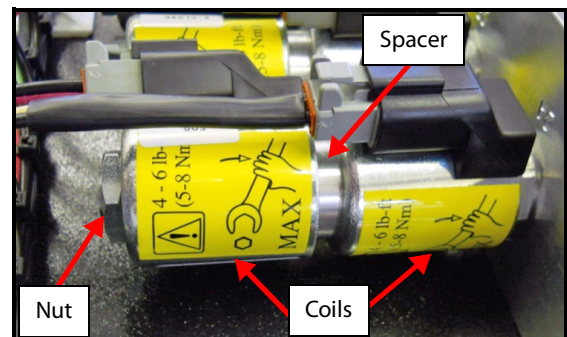

4. Loosen coil/solenoid valve retaining nut as shown below.
5. Remove old coil and install new coil with spacer if required. Torque coil/solenoid retaining nut to 4-6 ft-lbs (5-8 nm).

SECTION 7

Water Cannon System

6. Reconnect electrical plug into coils, refer to marked location upon removal.
7. Perform water cannon functional check.
8. Install upper assembly cover and secure mount bolts.

Solenoid Valve Replacement

1. Remove all electric and hydraulic power from the water cannon system and make unit safe for maintenance.
2. Remove control valve assembly upper cover to gain access to control components.
3. Mark and remove electrical connector for solenoid coil.
4. Remove retaining nut on solenoid and remove both coils and spacer.
5. Remove solenoid from hydraulic manifold.
6. Install new solenoid with O-rings.
7. Reinstall coil, spacer, coil stack-up as shown below. Torque retaining nut to 4-6 (5-8 nm) ft-lbs.

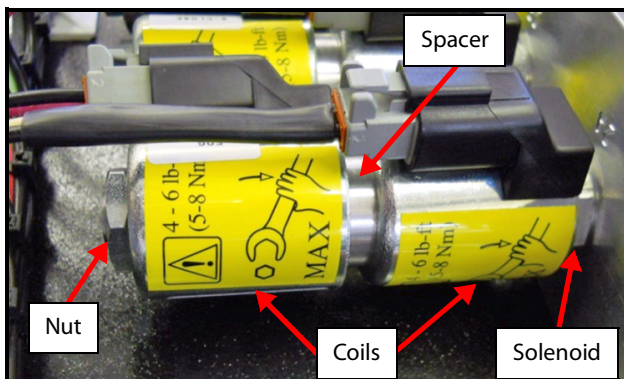

8. Reconnect electrical plug into coils, refer to marked location upon removal.
9. Perform water cannon functional check while checking for leaks.
10. Install upper assembly cover and secure mount bolts.

11. Service vehicle hydraulic system as required.

Pressure Reducer Replacement

1. Remove all electric and hydraulic power from the water cannon system and make unit safe for maintenance.
2. Remove control valve assembly upper cover to gain access to control components

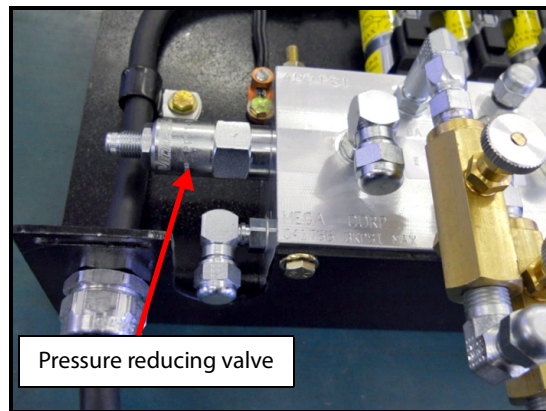

3. Remove old pressure reducer.
4. Install new pressure reducer.

CAUTION

Pressure reducer must be set to no more than 450 PSI (3,105 kpa). Damage will occur to the water cannon hydraulic motors if system is pressurized above 450 PSI. (3,105 kpa).

5. Install pressure gauge on water cannon hydraulic motor supply line (up-down-right or left) to observe system pressure while adjusting pressure relief valve.

SECTION 7

Water Cannon System

6. Loosen pressure reducer jam nut and insert Allen wrench in the pressure reducer adjustment stem.

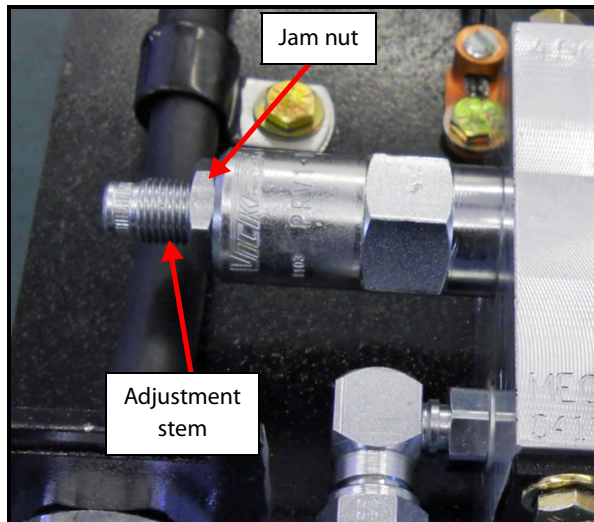

7. Apply hydraulic and electrical power to the water cannon system.
8. Move and hold the joystick to the same direction you installed the pressure gauge (up-down-right or left). While holding the joystick to that direction, adjust the pressure reducer adjustment stem to set 450 PSI (3,105 kpa).
9. Operate the water cannon in all directions checking for full range of motion.
10. Reinstall control valve assembly upper cover.
11. Service vehicle hydraulic system as required.

Control Valve Assembly Removal

1. Label and disconnect all hydraulic hoses.
2. Remove 2 mount bolts on the water cannon waterway flange and remove control valve assembly.

Control Valve Installation

1. Install control valve assembly on waterway lower flange and install mount bolts.
2. Tighten waterway mount bolts evenly to secure the control valve assembly and provide equal clamp up of flange to BFV.

3. Connect all labeled hoses to the appropriate function/location.
4. Pressurize the hydraulic water cannon system and check for hydraulic leaks.
5. Perform a water cannon functional check while inspecting for leaks and proper operation.
6. Service vehicle hydraulic system as required.

Hydraulic Adjustable Nozzle Adjustment Procedure

1. Ensure unit is safe for operation.
2. Ensure all spray system switches are OFF.
3. Ensure PARK BRAKE is SET.
4. Remove both hydraulic hoses from Hydraulic Adjustable Nozzle cylinder.
5. Inject 3 to 5 squirts of grease in grease fitting near the outlet of the nozzle by the cylinder rod end.
6. Move the Nozzle end IN or OUT by hand and apply 3 to 5 more squirts of grease in the grease fitting while the nozzle is in the opposite direction for where it initially started.

SECTION 7

Water Cannon System

7. Nozzle will be tight. Ensure Nozzle moves freely and is not binding on housing by moving it in and out by hand. NOTE: The travel of the outlet end of the Nozzle is less than 1 inch (26mm).

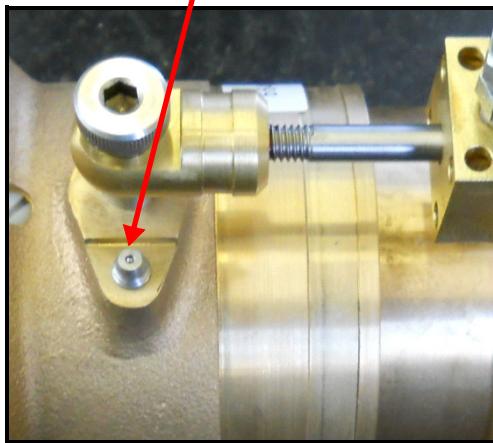
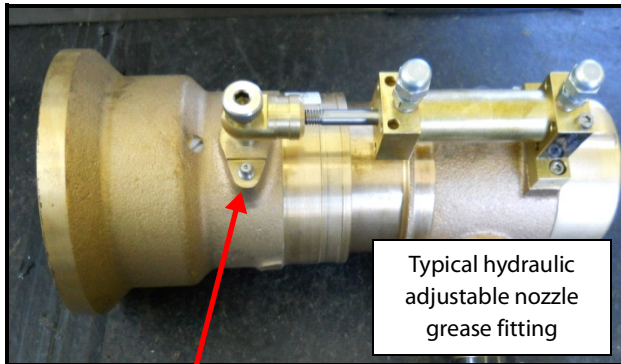

8. When Nozzle move freely, reconnect cylinder hydraulic hoses.
9. Start engine.
10. Operate engine at LOW IDLE.
11. Ensure Water Cannon Solenoid Control Valve receives 450+ psi of oil pressure and has less than 50 psi of return pressure.
12. Turn POWER switch ON. (If control system is pilot oil operated the water pump does not need to be engaged for this operation.
13. Observe Adjustable nozzle and operate NOZZLE switch.

14. If Nozzle operates too slow or fails to operate, bleed 2 hoses from control valve to nozzle until oil is free from trapped air, secure fittings.

15. Loosen jam nuts on both flow controls mounted on the MONITOR/BFV control valve.

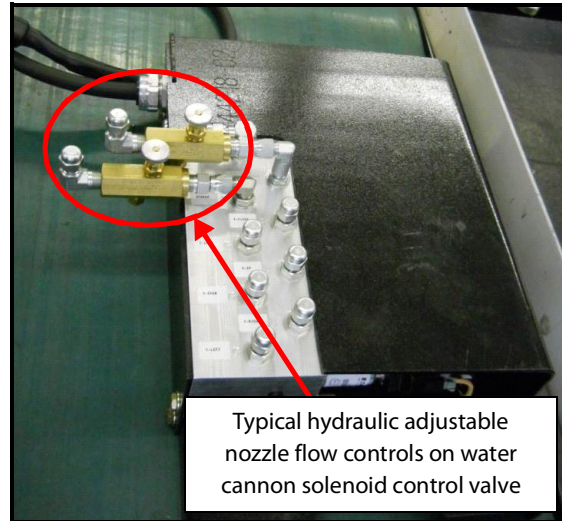

16. Unscrew both flow control knobs 1/2 turn.
17. Operate NOZZLE switch and observe nozzle operation.
18. If Nozzle fails to operate or is still too slow, ensure both solenoid coils are receiving the proper 24VDC signal and Solenoid control valve mounting plate has a secure ground. If all of these conditions are met contact MEGA product Support Group at US Toll free: 1-800-345-8889 or direct at: 1-505-345-2661 with both the Water Cannon Control Valve oil pressure and return pressure.
19. If Nozzle moves too quickly, screw in (CLOSE) the flow control knobs by only 1/8 turn each until desired speed is obtained.
20. When desired nozzle speed is achieved, lock jam nuts to prevent flow control valve adjustment from changing. Stow Nozzle in the vertical position.
21. Turn POWER switch OFF;
22. Turn ENGINE OFF.

SECTION 7

Water Cannon System

HYDRAULIC BFV

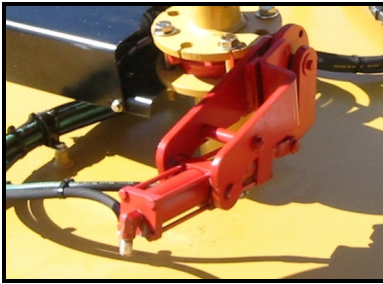

Description

A 3" valve that controls flow to the water cannon. A hydraulic cylinder extends or retracts based upon hydraulic flow from either the hydraulic control valve assembly (typically mounted below the water cannon) or the solenoid control box (typically mounted on the tank forward bulkhead) as commanded by the cab control.

Inspection

1. BFV assembly for security, mounting and evidence of water leaks.
2. Hydraulic components and hoses for leaks and condition.

Repair

BFV Removal

1. Remove all electrical/hydraulic power and make the vehicle safe for maintenance.
2. Ensure vehicle hydraulic system is not in operation.
3. Label and disconnect hydraulic extend and retract hoses from BFV hydraulic cylinder and cap hydraulic lines.
4. Remove water piping bolts that clamp BFV between the piping flanges and remove the BFV assembly.

BFV Installation

1. Position BFV between the water piping flanges and install clamping bolts.
2. Tighten clamping bolts equally to secure BFV between pipe flanges.

3. Connect hydraulic extend and retract hoses to the BFV cylinder.
4. Pressurize hydraulic system and check for leaks as well as component operation.
5. Service vehicle hydraulic system as required.

BFV Disassemble/Inspection & Reassemble

1. Remove clevis and cotter pin from hydraulic cylinder.
2. Loosen set screw on waterway valve and remove bellcrank.
3. Loosen all 4 BFV bracket mount bolts and disassembly brackets from the cylinder and waterway valve.
4. Inspect hydraulic cylinder for leaks.
5. Inspect waterway rubber seal for wear, cuts and condition.
6. Locate hydraulic cylinder pivot pins in side brackets.
7. Position waterway valve between side brackets and install 4 BFV bracket mount bolts.
8. Tighten BFV bracket mount bolt evenly while ensuring hydraulic cylinder still rotates freely on the pivot pins.
9. Install bellcrank on waterway valve shaft and tighten set screw.
10. Install clevis and cotter pin.

SECTION 7
Water Cannon System

SECTION 8 Fire Suppression System

Contents

Description	8-1	Electric Shut-off Valve	8-1
Foam Concentrate Tank	8-1	Foam Eduction Nozzle	8-2

DESCRIPTION

The system consists of a stainless steel holding tank, an electric or pneumatic actuated shut-off valve, in-cab controls, hosing, and a foam eduction nozzle. The system produces a blanket of fire suppressant foam used to battle several different classes of fires.

FOAM CONCENTRATE TANK



Description

A 227 L (60 gallon) or 454 L (120 gallon) stainless steel tank mounted in the forward upper portion of the water tank. The holding tank contains a supply tube that extends to the bottom of the tank. A flexible hose is connected to the supply pipe that is routed to the foam agent shut-off valve. The tank also contains a pressure/vacuum cap which keeps foreign matter out of the tank while providing for pressure relief and air displacement during temperature changes.

Inspection

1. Holding tank for damage, leaks and security.
2. Vented servicing cap for damage, and condition.
3. Foam supply tube for security, damage, leaks and signs of collapsing.

Repair

Foam Concentrate Hose Replacement

1. Remove all electrical/hydraulic power and make the vehicle safe for maintenance.
2. Remove hose clamps and hose.

3. Fit new hose between tank supply line and shutoff valve.
4. Install and tighten hose clamps while ensuring the hose fully engages and seals around the attaching point.
5. Perform a functional check of the system while ensuring there are no vacuum leaks around the hose attaching points.
6. Wash down all areas exposed to foam concentrate or finished foam.

ELECTRIC SHUT-OFF VALVE



Description

The in-line shut-off valve is mounted on the foam tank upper lip and controls flow of foam concentrate from the tank to the nozzle. The valve is controlled by the in-cab control FOAM switch is actuated by either an electric or pneumatic actuator. Once the shut-off valve is opened, foam concentrate will flow from the holding tank to the water cannon nozzle if the water cannon and water pump switches are ON.

Inspection

1. Valve assembly for security, condition and leaks.
2. Foam supply tube for security, damage, leaks and signs of collapsing.

SECTION 8

Fire Suppression System

Repair

Valve Assembly Replacement

1. Remove all electrical/hydraulic power and make the vehicle safe for maintenance.
2. Disconnect foam concentrate hosing.
3. Remove valve assembly.
4. Install new valve assembly and secure mount bolts.
5. Reconnect foam concentrate hosing.
6. Install and tighten hose clamps while ensuring the hose fully engages and seals around the attaching point.
7. Perform a functional check of the system while ensuring there are no vacuum leaks around the hose attaching points.
8. Wash down all areas exposed to foam concentrate or finished foam.

Inspection

1. Nozzle for lubrication, security and leaks.
2. Nozzle hardware and wiring for security and condition.
3. Foam supply tube for security, damage, leaks and signs of collapsing.

Repair And Adjustment

Flow Rate Adjustment

1. Remove the baffle head by placing and turning a bar—such as a long screwdriver—between two of the screw heads.
2. Insert the applicable flow spacer. Flow spacers are marked 500, 750, or 1000 GPM (no spacer = 350 GPM).
3. Ensure that the correct metering disc is being used for the desired foam percentage.

FOAM EDUCATION NOZZLE



Description

The foam education nozzle is a remote adjustable fog/stream nozzle is attached to the water cannon waterway. The nozzle inner housing uses water cannon high pressure water to create a venture effect that will create a suction force that pulls foam concentrate from the holding tank. Once foam concentrate is flowing, the nozzle proportions foam concentrate, water and air to produce finished foam. The nozzle contains a metering valve that allows for adjusting foam solution at a rate of 1%, 3% or 6%. Rate adjustment is obtained with either a removable disk.

SECTION 8

Fire Suppression System

Changing the Metering Disc

The foam eduction nozzle comes with 6 different metering discs, each designed for a particular Foam percentage at a particular flow rate. Each disc is identified by an alpha character (A–E) stamped into one side. Use the following chart to determine which disc to use:

		Flow Rate (GMP)			
		350	500	750	1000
Flow %	1%	A	D	F	B
	3%	B	E	C	No Spacer
	6%	C	No Spacer	N/A	N/A

1. Unscrew the pickup hose assembly from the nozzle body and remove the existing metering disc, if present.

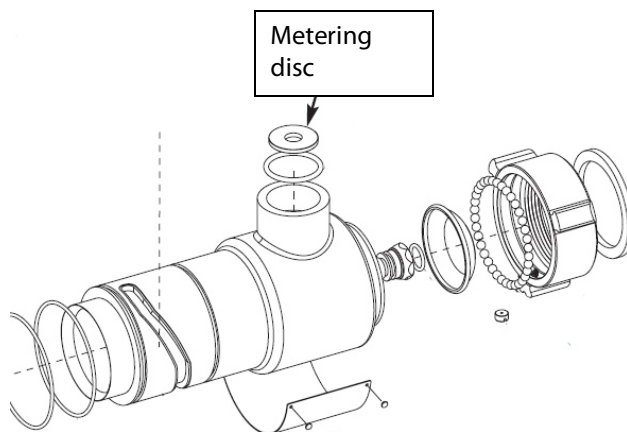

2. Insert the new metering disc into the exposed recess on the nozzle body.
3. Re-attach the Pickup Hose.

Nozzle Replacement

1. Remove all electrical/hydraulic power and make the vehicle safe for maintenance.
2. Remove foam concentrate supply line.
3. Unplug electrical connection from nozzle.
4. Unscrew nozzle base ring and remove nozzle from water cannon waterway.
5. Install new nozzle and tighten nozzle base ring.

6. Reconnect nozzle wiring.
7. Reconnect foam concentrate supply hose.
8. Install and tighten hose clamps while ensuring the hose fully engages and seals around the attaching point.
9. Ensure adequate lubrication has been applied to grease fitting for ease on movement, lubricate as required.
10. Perform a functional check of the nozzle system while ensuring there are no vacuum leaks around the hose attaching points.
11. Wash down all areas exposed to foam concentrate or finished foam.

SECTION 8
Fire Suppression System

SECTION 9

Rear Brake System (MST/MSC)

Contents

621K Brake System	9-1	Tank Pressure Sending Unit	9-2
621G/631G Brake System.....	9-1	Pneumatic Manifold Assembly	9-3
Theory Of Operation	9-1	Brake Pods	9-5
Air Tanks.....	9-2		

621K BRAKE SYSTEM

For service, repair, and replacement information concerning the CAT 621K braking system, follow the appropriate procedures and instructions outlined in CAT 621K Scraper Brake System in CAT SIS.

NOTE

In the case of a complete wheel group rebuild/replacement/component changeover, brake air purging is required. For the rear wheel groups, extra steps must be taken in addition to the procedures in CAT SIS: ensure that ALL air is purged from the wheel group service brake (using the installed quick connect on the wheel groups follow the CAT SIS drive axle wheel group service brake air purge procedures) and from the trailing axle brake oil cooling circuit.

621G/631G BRAKE SYSTEM

This section details exclusively the 621G and 631G braking system. The MST/MSC rear brake system is integrated with the existing 621G/631G tractor parking, service and emergency brakes. All three systems are activated with the existing brake controls located in the tractor cab. See the CAT 621G/631G operator and service manual for additional tractor brake information.

The MST/MSC (621G/631G) rear brake system consists of a wheel group, two additional air tanks, pneumatic manifold assembly, pneumatic brake relay valve, brake pods, solenoid valve, pressure switch, pressure sending unit and hosing.

NOTE

For MST/MSC 5, 613 Series II rear braking system information, refer to Section 10 or CAT 613 Scraper Brake System in CAT SIS and Operation and maintenance manual.

THEORY OF OPERATION

Parking Brake

The parking brake is applied by activating the parking brake switch in the tractor cab. Once the switch is moved to the park position, an electrical signal is sent to the parking brake solenoid valve mounted on the rear trailing axle pneumatic manifold. The sent signal will open the solenoid valve, which allows pneumatic pressure to decrease from one side of the brake pod. The brake pod coil spring can now overcome air pressure and extend the brake pod rod end attached to the wheel group brake lever and apply the brakes. Once parking brake pneumatic pressure drops below allowable limits, the parking brake pressure switch mounted on the pneumatic manifold will close and illuminate the parking brake warning light in the cab of the tractor.

The parking brake is released by activating the parking brake switch. Once the switch is moved, an electric signal is sent to close the parking brake solenoid valve. The valve closing will allow pneumatic pressure from the pneumatic manifold to be routed to the brake pod. This pressure increase will eventually overcome the brake pod coil spring and retract the brake pod cylinder rod end attached to the brake pod, which releases the brakes. Once pressure increases above allowable limits, the parking brake pressure switch will turn off the parking brake warning light in the tractor cab.

Service Brake

The service brake is applied by pressing down on the service brake pedal in the tractor cab. Pressing down on the pedal will send a pneumatic pressure signal to the service brake relay valve mounted on the rear trailing axle. The sent signal will release pneumatic pressure from the brake pod chamber, allowing the pod coil spring to extend the rod end and apply service brakes.

SECTION 9

Rear Brake System (MST/MSC)

The service brake is released by releasing the brake pedal. Once the pedal released, a pneumatic signal is received by the brake relay to increase air pressure to the brake pod. As pneumatic pressure increases the force of the brake pod coil spring is overcome and the service brake is released.

Emergency Brake

The emergency brake theory of operation is the same as the parking brake except for the means of activation. Activation is accomplished by using the emergency brake foot switch located on the floor of the tractor cab just left of the service brake pedal.

AIR TANKS

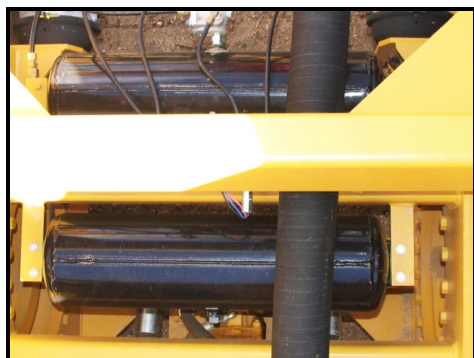

The MST/MSC is equipped with two 8 inch x 32 inch air cylinders mounted to the MST/MSC rear trailing axle that store 110-130 psi air each. The cylinders receive pressurized air from the tractor primary air tank mounted under the tractor cab.

Inspection

1. Tank for damage and condition.
2. Tank mounts and hardware for damage security and condition.
3. Fittings for obvious damage and evidence of pneumatic leaks.
4. Attached hoses for damage, condition and leaks.

Removal

1. Ensure vehicle is shutdown and pneumatic system is depressurized.
2. Disconnect pneumatic hoses, manifolds, and sensors as required.

3. Remove mounting bolts and remove tank.

Installation

1. Position air tank, install mounting bolts and torque mount bolts to standard torque value.
2. Reconnect manifolds, sensors and hoses as required.
3. Start up vehicle and pressurize pneumatic system.
4. Once system is at full pressure, inspect air tank and associated components for pneumatic leaks.
5. If no leaks are found check spray system components for proper operation.
6. Perform a complete functional check of the MST/ MSC parking, service and emergency brake systems.

TANK PRESSURE SENDING UNIT



A 24 VDC pressure sending unit is mounted to the rear MST/MSC air tank and is wired into existing tractor brake pressure indicating and warning systems. The sending unit provides air pressure sensing for the tractor air pressure gauge mounted in the dash. The sending unit also provides a signal to the brake low pressure warning system that sounds an audible warning tone when brake supply pressure drops below allowable limits.

Inspection

1. Sending unit and associated wiring for damage security and mounting.
2. Evidence of pneumatic leaks.

Removal

1. Disconnect electrical connections.
2. Remove mount bolts and sending unit.

SECTION 9

Rear Brake System (MST/MSC)

Installation

1. Position sending unit on the mounting plate and install mount bolts. Torque to standard torque value.
2. Connect sending unit to wire harnesses.
3. Perform operational checks by depressurizing the pneumatic system to ensure warning lights illuminate and audible tones are heard. Pressurize the system to ensure all audible tones and warning lights extinguish.

3. Disconnect pneumatic hoses as required.
4. Remove check valve assembly.
5. Inspect valve for obstructions and obvious damage to the spring and plunger.
6. Pressurize valve assembly and check for proper operation.

Installation

1. Install check valve assembly.
2. Connect pneumatic hoses as previously labeled.
3. Start up vehicle and pressurize pneumatic system.
4. Once system is at full pressure, inspect check valve for pneumatic leaks.
5. Perform a complete functional check of the MST/ MSC parking, service and emergency brake systems.

PNEUMATIC MANIFOLD ASSEMBLY

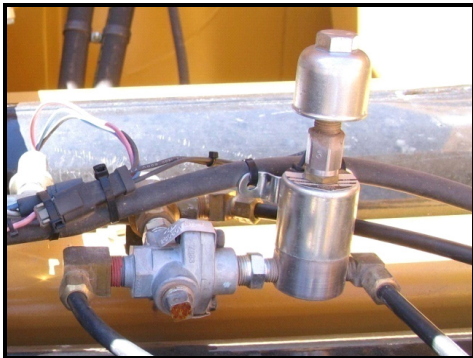

A pneumatic manifold mounted in the rear trailing axle used to route air pressure for service, parking and emergency brake operation. The manifold also provides mounting for a check valve, parking brake/emergency solenoid valve and parking brake pressure switch.

Check Valves

A spring operated valve allowing air flow in a predetermined direction. A one-way check valve is located at the MST/MSC rear air tank tractor air supply in. A double-check valve is located on the pneumatic manifold.

Inspection

1. Inspect for evidence of pneumatic leaks or obvious damage.

Removal

1. Ensure vehicle is shutdown and pneumatic system is depressurized.
2. Label all hoses for reinstallation.

Parking/Emergency Brake Solenoid

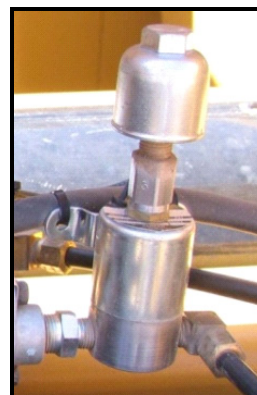

A 24 VDC electrical solenoid that opens or closes to control the parking or emergency brake function. The solenoid valve responds to electrical signals as commanded by the parking or emergency brake in the tractor cab. The solenoid valve will open to bleed off parking/emergency brake release pressure, from the brake pods. This release of air pressure will cause the parking/emergency brakes to be applied.

Inspection

1. Inspect for evidence of pneumatic leaks or obvious damage.
2. Inspect breather for damage and security.
3. Inspect wiring for damage, security and condition.

SECTION 9

Rear Brake System (MST/MSC)

Removal

1. Ensure vehicle is shutdown and pneumatic system is depressurized.
2. Disconnect pneumatic hoses as required.
3. Remove solenoid from manifold fitting.
4. Inspect solenoid for obstructions and obvious damage.

Installation

1. Install solenoid assembly on pneumatic manifold.
2. Connect pneumatic hoses as required.
3. Start up vehicle and pressurize pneumatic system.
4. Once system is at full pressure, inspect solenoid valve for pneumatic leaks.
5. Perform a complete functional check of the MST/ MSC parking and emergency brake systems.

Parking Brake Pressure Switch

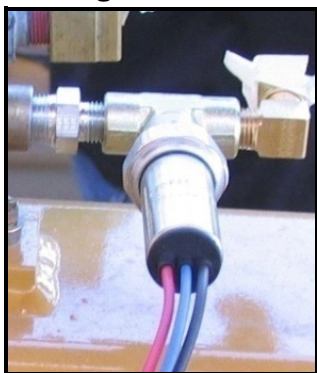

A 24 VDC pressure switch used to illuminate the parking brake warning light in the tractor cab. The sensor will turn on the parking brake warning light when parking brake release pressure drops below allowable limits.

Inspection

1. Inspect for evidence of pneumatic leaks or obvious damage.
2. Inspect wiring for damage, security and condition.

Removal

1. Ensure vehicle is shutdown and pneumatic system is depressurized.
2. Disconnect wire harness.
3. Remove pressure switch from t-fitting.
4. Inspect pressure switch for obstructions and obvious damage.

Installation

1. Install pressure switch on t-fitting.
2. Connect wire harness.
3. Start up vehicle and pressurize pneumatic system.
4. Once system is at full pressure, inspect pressure switch for pneumatic leaks.
5. Perform a complete functional check of the MST/ MSC parking brakes and warning systems.

Service Brake Relay Valve



A pneumatic relay that controls and routes air tank activation pressure to both brake pods. The relay controls air pressure applied to the brake pods as commanded by a pneumatic signal generated by activating the service brake pedal located in the tractor cab.

Inspection

1. Inspect for evidence of pneumatic leaks or obvious damage.
2. Inspect hoses and fittings for damage, security and leaks.

SECTION 9

Rear Brake System (MST/MSC)

Removal

1. Ensure vehicle is shutdown and pneumatic system is depressurized.
2. Label all hoses for reinstallation.
3. Disconnect pneumatic hoses.
4. Remove relay valve.
5. Inspect solenoid for obstructions and obvious damage.

Installation

1. Install relay valve on air tank.
2. Connect pneumatic hoses as previously labeled.
3. Start up vehicle and pressurize pneumatic system.
4. Once system is at full pressure, inspect relay valve for pneumatic leaks.
5. Perform a complete functional check of the MST/ MSC service brake system.

BRAKE PODS



A pneumatic cylinder designed to extend or retract and apply service, parking or emergency brakes. The pods are mounted to the MST/MSC rear trailing axle and are connected to the wheel group brake activation lever. The pod contains a coil spring and responds to pressure received from the brake relay valve as commanded by service brake pedal. The pod will also apply parking or emergency brakes when one side of the cylinder is depressurized when commanded by the activation of the parking or emergency brakes. Loss of pneumatic pressure allows the brake pod coil spring to extend the rod end.

Inspection

1. Inspect pod for obvious damage, security and condition.
2. Inspect pneumatic supply hose and fittings for security, condition and leaks.
3. Inspect pod rod-end and hardware for damage, security and condition.

Removal

1. Ensure vehicle is shutdown and pneumatic system is depressurized.
2. Label all hoses for reinstallation.
3. Cage brake pod.
4. Disconnect pneumatic hoses.
5. Remove rod-end clevis pin from wheel group brake lever.
6. Remove brake pod mount bolts and remove brake pod.

Installation

1. Install brake pod and adjust rod-end clevis so slip fit is obtained with the clevis pin.
2. Lengthen rod-end by 1/2 turn (longer) and install rod-end clevis pin. Tighten rod-end jam nut and pod mount bolts.
3. Connect pneumatic hoses as previously labeled.
4. Remove caging bolt.
5. Start up vehicle and pressurize pneumatic system.
6. Once system is at full pressure, inspect brake pod and pneumatic hoses for pneumatic leaks.
7. Perform a complete functional check of the MST/ MSC service, parking and emergency brake system.

SECTION 9
Rear Brake System (MST/MSC)

SECTION 10

Scheduled Maintenance Inspections

Contents

Description	10-1	MST/MSC Additional.....	10-3
Spray heads	10-1	M-4, M-4B Water Pump System	10-5
Control System.....	10-2	M-3 Water Pump System	10-6
Tank Structure	10-2		

DESCRIPTION

This section establishes scheduled maintenance inspections of the installed MEGA Water Tank at the designated frequencies. Performing these inspections will identify potential system discrepancies and allow preventative maintenance to be performed before a component or system is rendered totally inoperative.

NOTE

Vehicles operated in extremely low quality water environments may require more frequent inspections.

		FREQUENCY								
STEP	SPRAY HEADS	WEEKLY	BI-WEEKLY	MONTHLY	QUARTERLY	SEMI-ANNUAL	ANNUAL	HOURS PER INSPECTION	TOTAL ANNUAL HOURS	
		(150 HRS)	(250 HRS)	(500 HRS)	(1000 HRS)	(2500 HRS)	(5000 HRS)			
1	Check spray head for damage and clean deflector ring and spray head opening.	X						0.3	10.0	
2	Check hydraulic lines for security, damage and leaks.	X						0.3	10.0	
3	Check spray head drop-in assembly for leaks with spray head switch OFF and water pump ON. Replace drop-in assembly as required.			X				0.3	3.0	
4	Check spray head base plate and upper housing mount bolts for security.			X				0.2	2.0	
5	Check spray head adjustable deflector ring for damage and correct adjustment. Apply dry-film lubricant to the deflector inner ring.			X				0.6	6.0	
6	Check spray head base plate for evidence of leaks. Replace base plate O-ring as required.						X	0.2	0.2	
									31.2 Total	

SECTION 10

Scheduled Maintenance Inspections

		FREQUENCY							
STEP	CONTROL SYSTEM	WEEKLY (150 HRS)	BI-WEEKLY (250 HRS)	MONTHLY (500 HRS)	QUARTERLY (1000 HRS)	SEMI-ANNUAL (2500 HRS)	ANNUAL (5000 HRS)	HOURS PER INSPECTION	TOTAL ANNUAL HOURS
1	Check all electrical cables for security and damage. Disconnect, clean and coat Deutsch connector junctions with Dielectric grease as required.			X				0.7	7.0
2	Check all hydraulic solenoids and hosing for security and leaks.				X			0.3	1.5
3	Check monitor/nozzle assembly for security leaks and condition. Repair as required.				X			0.2	1.0
4	Check foam agent supply hoses and shut-off valve for security condition and evidence of suction leaks.				X			0.1	0.5
5	Check all in-cab control functions for proper operation. Repair and replace control components as required.				X			0.7	3.5
6	Check hose reel for security mounting and leaks.			X				0.2	2.0
7	Unreel the entire length of hose, pressurize hose and check hose and nozzle for security, wear and leaks.						X	0.6	0.6

16.1
Total

STEP	TANK STRUCTURE	WEEKLY (150 HRS)	BI-WEEKLY (250 HRS)	MONTHLY (500 HRS)	QUARTERLY (1000 HRS)	SEMI-ANNUAL (2500 HRS)	ANNUAL (5000 HRS)	HOURS PER INSPECTION	TOTAL ANNUAL HOURS
1	Check filler port trash screen for debris and inspect assembly for security and damage. Repair or replace trash screen as required.	X						0.2	6.7
2	Visually inspection tank exterior for damage and evidence of leaks. Repair as required			X				0.5	5.0
3	Drain tank and remove water pump sump access cover. Remove trash and inspect sump area for damage.			X				0.5	5.0
4	Check all lights (turn signal, brake, backing, parking, clearance and work) for proper operation. Replace lights as required.			X				0.6	6.0
5	Check all interior tank structure for leaks, cracks and condition of epoxy coating (if equipped). Repair structure and coatings as required.					X		3.0	6.0
6	Check body pad and guides for cracks, security and damage. Repair or replace as required.	X						0.3	10.0

38.7
Total

SECTION 10

Scheduled Maintenance Inspections

NOTE

MEGA MST/MSC model water tanks require additional maintenance checks outlined in the following tables.

STEP	MST/MSC ADDITIONAL	FREQUENCY					HOURS PER INSPECTION	TOTAL ANNUAL HOURS
		WEEKLY (150 HRS)	MONTHLY (500 HRS)	QUARTERLY (1000 HRS)	SEMI-ANNUAL (2500 HRS)	ANNUAL (5000 HRS)		
1	Check the bogie structure for any cracking. Close attention should be paid to all gusseting, as well as to the wheel group mounting plates. Repair structure as required.					X	3.0	3.0
2	Check all components on the bogie for leaks and/or damage. These components include air tanks, air lines, brake pods, hydraulic connections, spray bar, dump bar, and wheel groups. Repair or replace as required.		X				1.0	10.0
3	<p>(DROP HITCH ONLY)</p> <p><u>STRUCTURE</u>: Check draft arms, fuel tube and gooseneck structure for damage, cracks and security. Repair as required. Inspect draft arm trunnion attaching bolts for security at tank joint.</p> <p><u>FUEL SYSTEM</u>: Inspect tank, fuel system components and fill system for damage, security and leaks. Repair or replace as required.</p> <p><u>HYDRAULICS</u>: Inspect lift cylinders, steering cylinders and implement valve for security, damage and leaks. Inspect all hydraulic hoses for damage, security, chaffing and leaks.</p> <p><u>CONTROLS/ELECTRICAL</u>: Check all wiring harnesses for damage and security. Inspect all connectors and repair as required.</p>		X				2.0	20.0
								33.0 Total (Drop)

SECTION 10

Scheduled Maintenance Inspections

		FREQUENCY						
STEP	MST/MSC ADDITIONAL	WEEKLY (150 HRS)	MONTHLY (500 HRS)	QUARTERLY (1000 HRS)	SEMI-ANNUAL (2500 HRS)	ANNUAL (5000 HRS)	HOURS PER INSPECTION	TOTAL ANNUAL HOURS
4	<p>(RIGID HITCH ONLY)</p> <p><u>STRUCTURE</u>: Check fuel tube and gooseneck structure for damage, cracks and security.</p> <p><u>FUEL SYSTEM</u>: Inspect tank, fuel system components and fill system for damage, security and leaks. Repair or replace as required.</p> <p><u>HYDRAULICS</u>: Inspect steering cylinders and water pump control valve for security, damage and leaks. Inspect all hydraulic hoses for damage, security, chaffing and leaks.</p> <p><u>CONTROLS/ELECTRICAL</u>: Check all wiring harnesses for damage and security. Inspect all connectors and repair as required.</p>		X				1.5	15.0
								15.0 Total (Rigid)

SECTION 10

Scheduled Maintenance Inspections

STEP	M-4, M-4B WATER PUMP SYSTEM	150 HRS (WEEKLY)	250 HRS (BI-WEEKLY)	500 HRS (MONTHLY)	1,000 HRS (QUARTERLY)	5,000 HRS (ANNUALLY)	HOURS PER INSPECTION	TOTAL ANNUAL HOURS
1	Remove water pump from unit and check: water pump impeller retaining bolt/nut for security and for damage or contact to the impeller, impeller keyways for wear and security, shaft bearings for signs of heating and wear, drive end shaft keyways for signs of damage and heating and seals for security, damage and over or under lubrication. Check volute case for damage or contact. Check both of the impeller wear rings for damage and excessive wear (0.020" or 0.5 mm nominal tolerance) Check packing mount for security. (Disassembly of water pump is required to perform these maintenance operations). Repair as required.					X	5.0	5.0
2A	(This Step For M-4 Pump Only) Check shaft seals for excessive lubricant leakage and water leakage. Lubricate water pump with a manual grease gun only. When lubricating the drive motor side shaft bearing and the impeller end bearing, apply 16 to 20 squirts (injections) of grease (2 fl. oz. or 60 cc) to each. Apply 4 or 5 squirts (injections) of grease to lantern ring grease fitting. Adjust, repair or replace as required.		X				0.3	6.0
2B	(This Step For M-4B Pump Only) Check shaft seals for excessive lubricant leakage and water leakage. When lubricating, apply 5.5 fl oz (150 cc) of grease to the drive end bearing and 2.5 fl oz (75 cc) of grease to the impeller end bearing. Adjust, repair or replace as required.		X				0.3	6.0
3	Check water pump and drive motor for leaks, excessive vibration/noise leaks and evidence of excessive heating. Repair as required.	X					0.3	10.0
4	Check rope seals for excessive water leakage, compression, wear and overheating. Adjust rope packing seal packing gland or replace rope packing seals as required.	X					0.3	10.0
5	Check water pump inlet and discharge piping for security, leakage and misalignment. Repair leaks as required.		X				0.2	4.0
								41.0 Total

SECTION 10
Scheduled Maintenance Inspections

STEP	M-3 WATER PUMP SYSTEM	150 HRS (WEEKLY)	250 HRS (BI-WEEKLY)	500 HRS (MONTHLY)	1,000 HRS (QUARTERLY)	5,000 HRS (ANNUALLY)	MANHOURS PER INSPECTION	Total Annual Hours
1	Remove water pump from unit and check: water pump impeller retaining bolt/nut for security and for damage or contact to the impeller, impeller keyways for wear and security, shaft bearings for signs of heating and wear, drive end shaft keyways for signs of damage and heating and seals for security, damage and over or under lubrication. Check volute case for damage or contact. Check both of the impeller wear rings for damage and excessive wear. Check packing mount for security. (Disassembly of water pump is required to perform these maintenance operations). Repair as required.					X	5.0	5
2	Check shaft seals for excessive lubricant leakage and water leakage. Lubricate water pump with a manual grease gun only. When lubricating the drive motor side shaft bearing and the impeller end bearing, apply 16 to 20 squirts (injections) of grease (2 fl. oz. or 60 cc) to each. Adjust, repair or replace as required.		X				.3	6
3	Check water pump and drive motor for leaks, excessive vibration/noise leaks and evidence of excessive heating. Repair as required.	X					.3	10
4	Check rope seals for excessive water leakage, compression, wear and overheating. Adjust rope packing seal packing gland or replace rope packing seals as required.	X					.3	10
5	Check water pump inlet and discharge piping for security, leakage and misalignment. Repair leaks as required.		X				.2	4
								35.0 Total

Index

A – D

A

AUTO Mode. *See* DiSCS®.

AUX 1, 3-10, 3-14, 3-17, 3-20

AUX 2. *See* Suction Loading

B

BFV (*switch*). *See* Water Cannon

Brake System (MSC/MST)

621G/631G

Air Tanks

description, 9-2

inspection, 9-2

installation, 9-2

Brake Pods

Description, 9-5

Inspection, 9-5

Installation, 9-5

Removal, 9-5

Overview, 9-1

Pneumatic Manifold Assembly, 9-3

check valves, 9-3

parking brake pressure switch, 9-4

parking/emergency brake solenoid, 9-3

service brake relay valve, 9-4

Tank Pressure Sending Unit

description, 9-2

inspection, 9-2

installation, 9-3

removal, 9-2

Theory of Operation

Emergency Brake, 9-2

Parking Brake, 9-1

Service Brake, 9-1

621K, 9-1

Butterfly Valve

Abbreviation of, 1-5

Description, 4A-2

Disassembly & Reassembly, 4A-3

Drain, 3-10

Dump Bar, 3-2, 3-11, 3-17

Inspection, 4A-2

Installation, 4A-2

Pneumatic

Description, 6-19

Inspection, 6-19

Repair, 6-19

Removal, 4A-2

Tank Drain, 3-17

Water Cannon, 3-11, 3-20, 7-9

inspection, 7-9

maintenance, 7-9

C

Cab Control System

Analog

description, 3-1

function descriptions, 3-1–3-2

Inspection, 3-2

power, 3-1

Repair

joystick replacement, 3-2

switch replacement, 3-2

Solenoid Driver Card, 3-3–3-5

Water Level Gauge

diagnostic codes, 3-6–3-7

replacement, 3-5

Hydraulic Oil Filter Service, 3-29–3-30, 6-10–6-11

Inspection, 3-22

Power (*switch*), 3-12, 3-17–3-18

Solenoid Control Box, 1-7

Location (*MAC*), 1-6

Troubleshooting, 3-75–3-77

Checker-boarding. *See* DiSCS® - Gen 1.5 - distance-based mode, 3-12

Control System

Scheduled Inspections, 10-2

D

DIP Switches, 3-31, 3-36, 3-55–3-58, 3-76

See also DiSCS®, 3-31

DiSCS®

Controllers, 3-61

Fuse Replacement, 3-26

programming, 3-41–3-42, 3-51–3-52, 3-60

Gen 1.0

Overview, 3-16

Auto Mode, 3-17, 3-20–3-21

Configuration and Programming

Address Switches (*Controllers*), 3-60–3-61

Address Switches (*Master, Joystick, ISCS*), 3-58–3-59

DIP Switches, 3-55–3-58

Firmware Loading, 3-62–3-73

Line Code, 3-53–3-58

function descriptions (*extended*), 3-18–3-20

Intermittent Mode, 3-19

INTMNT (*switch*), 3-17

Power, 3-16

Reduced Volume Mode, 3-21

Repair

Index

F – H

Joystick Box and Switch Box Replacement, 3-22–3-23

Switch Replacement, 3-23

theory of operation, 3-17

Gen 1.5

Configuration and Programming

Address Switches (*Controllers*), 3-41–3-42

Address Switches (*Master, Joystick, ISCS*), 3-39–3-40

DIP Switches, 3-36

Firmware Loading, 3-43–3-52

Line Code, 3-34

Distance-Based Mode, 3-16

F1, 3-10, 3-12–3-13, 3-15–3-16

F2, 3-10, 3-12–3-13, 3-15–3-16

function descriptions (*brief*), 3-10–3-11

function descriptions (*extended*), 3-12–3-15

Intermittent Mode, 3-13

INTMNT (*switch*), 3-10, 3-12

Power, 3-10

Power (*switch*), 3-12

PWM Mode, 3-15

Reduced Volume Mode, 3-15

Repair

Switch Replacement, 3-25

theory of operation, 3-11

Ground Speed Sensing (GPS)

Gen 1.0, 3-20

Troubleshooting, 3-79

Inspection, 3-22

Repair

Solenoid Control Box

Coil Replacement, 3-27

Hydraulic Oil Filter Service, 3-29–3-30

Pressure Reducing Valve Replacement, 3-28

Solenoid Valve Cartridge Replacement, 3-28

Troubleshooting, 3-75–3-77

Water Level Gauge

Troubleshooting and Repair, 3-31

Water Level Sensor

cable replacement, 3-30–3-31

Distance-Based Mode, 3-16

See also DiSCS® – Gen 1.5

Drain (*component*)

Description, 6-20

Inspection, 6-20

Repair, 6-21

Drain (*switch*), 3-2, 3-10, 3-17

Drive Motor. See Water Pumps

Dump Bar

Gravity, 3-14, 3-20

Pressure, 3-13, 3-19

Dump Bar (*component*)

Description, 6-20

Inspection, 6-20

Repair, 6-20

F

F1. See DiSCS® – Gen 1.5

F2. See DiSCS® – Gen 1.5

Fire Suppression System

Electric Shut-Off Valve

description, 8-1

inspection, 8-1

valve assembly replacement, 8-2

Foam (*switch*), 3-1, 3-11, 3-14, 3-17, 3-20

Foam Concentrate Tank

description, 8-1

hose replacement, 8-1

inspection, 8-1

Foam Lock, 3-11, 3-14

Nozzle, Foam Eduction, 8-2

changing the metering disc, 8-3

flow rate adjustment, 8-2

inspection, 8-2

nozzle replacement, 8-3

Foam (*switch*). See Fire Suppression System.

Front Bumper Spray Bar, 6-23

H

Hoist Compatible

See Hoisting

Hoisting

Lowering, 2-3–2-4

Preparation and Raising, 2-2–2-3

Reconfiguration, 2-4

Water Pump Operational Check, 2-5

Hose (*switch*), 3-10, 3-14, 3-17, 3-20

Hose Reel

Location, 1-7

Location (*MAC*), 1-6

Retract Speed Adjustment, 6-21

Hydraulic Control Valve (*MSC/MST*)

Description, 4B-1

Flange Seal Replacement, 4B-1

Inspection, 4B-1

Manifold Replacement, 4B-1

Index

I – S

Piloted Solenoid Valve Replacement, 4B-2
Pressure Relief Valve Replacement, 4B-2

I

Intermittent Spray, 3-13, 3-19

J

Joystick, 3-1, 3-11, 3-14, 3-17, 3-20

See also Cab Control System and DiSCS®

Joystick Box

Programming, 3-35, 3-39–3-40, 3-51, 3-58, 3-73
Replacement, 3-22

M

M-3 Water Pump. *See* Water Pumps

M-4 Water Pump. *See* Water Pumps

M-4B Water Pump. *See* Water Pumps

MASS, 2-1

MAST, 2-1

Monitor, 3-1

See also Water Cannon

N

Nozzle (switch), 3-11, 3-14, 3-17

O

Oil Filter, Hydraulic. *See* DiSCS® - Repair - Solenoid Control Box and Cab Control System, 3-29

Oil Filter, Hydraulic. *See* Cab Control System, 6-10

P

Pause (function, switch), 3-10, 3-12

See also DiSCS® – Gen 1.5

Programming Jumpers, 3-52, 3-65–3-66, 3-71, 3-75

Pump (switch), 3-1, 3-10, 3-12–3-13, 3-17–3-19

PWM Mode, 3-15

See also DiSCS®

R

Rate. *See* DiSCS® – Auto Mode

S

Safety Messages, 1-2

Solenoid Control Box

Hydraulic

Coil Replacement, 6-11

Description, 6-9

Inspection, 6-10

Pressure Reducing Valve Replacement, 6-12

Solenoid Valve Cartridge Replacement, 6-12

Pneumatic

Butterfly Valve, 6-19

Inspection, 6-19

Repair, 6-19

Description, 6-13

Inspection, 6-13

Parts Identification, 6-14

Solenoid Valve Cartridge Replacement, 6-14

Solenoid Valve Indicator Lights, 6-16

Solenoid Valve Replacement, 6-18

Solenoid Driver Card. *See* Cab Control System - Analog, 3-3–3-5

Speed. *See* DiSCS® – Auto Mode

Spray Heads

Cab Control Switches, 3-13, 3-19

Hydraulic

Adjustable Ring, 6-1

Cylinder Replacement, 6-3

Description, 6-1

Drop-in Assembly, 6-4

Inspection, 6-2

Lubrication, 6-3

Replacement, 6-2

Spring Replacement, 6-5

Upper Housing Breather Port, 6-6

Locations, 1-7

Locations (MAC), 1-6

Pneumatic

Description, 6-7

Drop-in Assembly, 6-8

Inspection, 6-7

Spray Head Replacement, 6-7

Spring Replacement, 6-9

Troubleshooting, 3-78

Suction Loading, 3-13–3-14, 3-19–3-20

Description, 6-21

Inspection, 6-21

Index

T – W

Limitations, 6-21
Repair, 6-21

T

Tank Structure

Anodes, 2-1
Inspection, 2-5
MASS, 2-1
MAST, 2-1
Repair
 interior coating, 2-5
 leaks, 2-6
 paint, 2-5

Tank-Mounted Hydraulic Manifold

Description, 4A-1
Flange Seal Replacement, 4A-1
Inspection, 4A-1
MAC Hydraulic Manifold Replacement, 4A-1

W

Water Cannon

BFV (*switch*), 3-11, 3-14, 3-17, 3-20
Butterfly Valve, Hydraulic, 7-9
Cold Weather Storage, 7-1
Description, 7-1
Electric, 7-1
Hydraulic, 7-1
Hydraulic Control Valve Assembly
 coil replacement, 7-5
 description, 7-5
 inspection, 7-5
 installation, 7-7
 pressure reducer replacement, 7-6
 pressure reducer, settings, 7-6
 removal, 7-7
 solenoid valve replacement, 7-6
Inspection, 7-2
Joint Rebuild, 7-2–7-3
Location, 1-7
Location (*MAC*), 1-6
Logic Box, 7-4
 Replacement, 7-5
Motor Replacement, 7-2
Nozzles
 Adjustment, Hydraulic, 7-7–7-8
 Fog/Stream, 3-11
Stop Adjustment, 7-4

Stowing/Storage, 7-1

Water Level

Indicator, 3-2, 3-10, 3-13, 3-17–3-19
 Troubleshooting and Repair, 3-31
Low Water, 3-12–3-13, 3-18
Sensor
 cable replacement, 3-30–3-31
See also Water Pumps.

Water Pumps

Crossover Assembly, 5-1, 5-13
Data Tag, 5-20
Functional Check, 5-53–5-54
Grease Cavity Vents, 5-19
Grease Fittings, 5-15, 5-18
Hydraulic Drive Motor
 Cavitation, 5-8
 Contamination, 5-8
 Coupling and Mount, Disassembly, 5-27, 5-40
 Couplings, Identification, 5-21
 Description, 5-2
 Disassembly, 5-4–5-8
 Drive Motor Installation, 5-2
 Drive Motor Removal, 5-2
 flow control, 5-13
 Inspection, 5-2
 Lubrication, 5-12
 Manifold Seal Replacement, 5-2
 port identification, 5-2
 Reassembly, 5-8–5-12
 rotation, 5-1
 speed control, 5-13
Identification of, 5-15–5-21
Limitations, 3-78, 5-14
Location, 1-7
Location (*MAC*), 1-6
M-3
 Components, 5-15
M-3 Pump
 components
 Description, 5-22
 Identification, 5-15
 Inspections, 5-23
 Installation, 5-30
 Limitations, 5-24
 Lubrication, 5-23, 5-30
 Repair
 Disassembly, 5-26–5-28
 Drive Coupling, 5-27
 Impeller, 5-26
 Motor Mount, 5-27
 Reassembly, 5-28–5-30
 Removal, 5-25
 Shaft & Bearing Assembly, 5-27

Index

W – W

- Volute Case, 5-26
 - Rope Seal Replacement, 5-24
 - Rotation, 5-22
 - M-4
 - Identification, 5-16
 - M-4 Pump
 - components
 - Limitations, 5-35
 - Lubrication, 5-14, 5-35
 - Repair
 - Disassembly, 5-37–5-41
 - Drive Coupling, 5-40
 - Impeller, 5-38
 - Impeller Retaining Nut (*Gen 2*), 5-37–5-38
 - Impeller Retaining Nut (*Gen 3*), 5-37, 5-39
 - Motor Mount, 5-40
 - Packing Mount, 5-39
 - Reassembly, 5-42–5-44
 - Removal, 5-37
 - Shaft & Bearing Assembly, 5-40
 - Volute Case, 5-37
 - Rope Seal Replacement, 5-36
 - M-4B Pump
 - components
 - Description, 5-44
 - Identification, 5-16
 - Lubrication, 5-44, 5-49, 5-53
 - Repair
 - Impeller, 5-46, 5-51–5-52
 - Installation, 5-53
 - Packing Assembly, 5-47
 - Reassembly, 5-48
 - Removal, 5-45
 - Rope Seal Replacement, 5-45
 - Seal Plate, 5-47, 5-50–5-51
 - Shaft & Bearing Assembly, 5-47–5-48
 - Shaft Installation, 5-48
 - Volute Case, 5-46, 5-52
 - Operational Check, 2-5
 - Protection Features (*DiSCS*®), 3-12, 3-18
 - RPM Adjustment, 5-55–5-56
 - RPM Specifications, 3-78, 5-14, 5-55
-

Index